

# Cells in Space

(NASA-CP-10034) CELLS IN SPACE (NASA)  
310 p C5CL 06C

N90-13939  
--THRU--  
N90-13958  
Unc1as  
G3/55 0239677

*Proceedings of the  
Cells in Space-II Conference  
held at San Juan Bautista, California  
October 31 - November 4, 1988*

---



---

# Cells in Space

*Edited by*

Jean D. Sibonga and Richard C. Mains  
*Mains Associates  
Berkeley, California*

Thomas N. Fast  
*University of Santa Clara  
Santa Clara, California*

Paul X. Callahan and Charles M. Winget  
*Ames Research Center  
Moffett Field, California*

*Proceedings of the  
Cells in Space-II Conference  
held at San Juan Bautista, California  
October 31 - November 4, 1988*

**NASA**

National Aeronautics and  
Space Administration

**Ames Research Center**  
Moffett Field, California

## TABLE OF CONTENTS

	PAGE
EXECUTIVE SUMMARY .....	vii
FOREWORD .....	xi
P.X. Callahan	
BACKGROUND AND GOALS .....	xiii
P.X. Callahan, C.M. Winget, C. C. Kubokawa	
CONFERENCE PROGRAM .....	xv
OPENING REMARKS .....	xv
Co-Chairmen: R. S. Bandurski and P. Todd	
ABSTRACTS/SUMMARIES OF ORAL PRESENTATIONS .....	1
(Presenters and Titles of Oral Presentations Follow)	
<b>SESSION I DOES MICROGRAVITY AFFECT CELL STRUCTURE AND/OR CELL FUNCTION?</b> .....	<b>3</b>
1. C. Winget <i>Fundamental Results from Microgravity Cell Experiments with Possible Commercial Applications</i>	
2. W. Hymer <i>Cell Secretion in Microgravity</i>	
3. G. Sonnenfeld <i>Response of Lymphocytes to a Mitogenic Stimulus during Space Flight</i>	
4. A. Krikorian <i>Polarity Establishment and Morphogenesis in Cultured Plant Cells in Space</i>	
Open Discussion: A. Cogoli, Facilitator .....	6
<b>SESSION II BIOPHYSICAL PHENOMENA AND THE GRAVITY RESPONSE</b> .....	<b>9</b>
5. B. Taylor <i>The Sensory Transduction Pathways in Bacterial Chemotaxis</i>	
6. P. Todd <i>Physical Phenomena and the Microgravity Response</i>	
7. D. Clifford <i>Electrophoresis and Microgravity</i>	
8. T. Björkman <i>How to Detect when Cells in Space Perceive Gravity</i>	
9. R. Bandurski <i>Targets for the Gravity Stimulus: Voltage-Gated Channels</i>	
Open Discussion: P. Callahan, Facilitator .....	13
<b>SESSION III GRAVITY UNLOADING - UNDERSTANDING THE INPUT AND OUTPUT MECHANISMS OF THE ORGANISM RESPONSIBLE FOR THE TRANSFORMATION OF INERTIAL ACCELERATION INTO A RESPONSE</b> .....	<b>17</b>
10. A. Brown <i>Gravity Receptors and Responses</i>	
11. J. Kessler <i>Free Swimming Organisms in Microgravity</i>	
12. D. Cosgrove <i>Gravitropism in Plants: Hydraulics and Wall Growth Properties in Responding Cells</i>	
13. J. Frangos <i>Flow Effects on Osteoblasts</i>	
14. L. Wiley <i>Gravity and Preimplantation Development</i>	
Open Discussion: J. Duke, Facilitator .....	21

PRECEDING PAGE BLANK NOT FILMED

SESSION IV	HARDWARE DESIGN CONCEPTS AND OTHER FACTORS WHICH CAN INFLUENCE CELL BIOLOGY IN SPACE .....	27
15.	C. Bruschi <i>Fermentation Growth and Microgravity</i>	
16.	D. Chapman <i>Ground Based Simulations</i>	
17.	E. Dunlop <i>Plasma Separated Membrane Bioreactor: Results from Model System Studies</i>	
18.	S. Curtis <i>Impact of Radiation on Microgravity Experiments</i>	
19.	P. Callahan <i>Instrumentation: The Additional Factor that Affects Microgravity Bioscience Experiments</i>	
	Open Discussion: R. Gruener, Facilitator .....	30
SESSION V	INVESTIGATOR SENSITIZATION TO MISSION REQUIREMENTS AND CONSTRAINTS .....	33
20.	R. Ballard <i>Limitations on Science Due to Mission Constraints</i>	
21.	W. Gonzalez <i>Human Factors Issues in Performing Life Sciences in a 0-G Environment</i>	
22.	G. Jahns <i>Future Unmanned Space Flights</i>	
23.	J. Lashbrook <i>Mission Requirements and Constraints on Experiment Hardware</i>	
24.	T. Schnepf <i>Telescience</i>	
	Open Discussion: B. Dalton, Facilitator .....	36
SESSION VI	EXPERIMENTAL AND COMMERCIAL APPLICATIONS IN MICROGRAVITY .....	41
25.	L. Milov <i>NASA Commercial Space Life Sciences</i>	
26.	P. Seshan <i>Design Considerations for Space Bioreactors</i>	
27.	M. Deuser <i>Meeting the Investigator's Hardware Requirements</i>	
28.	W. Hymer <i>Center for Cell Research</i>	
29.	M. Luttgies <i>Countermeasures to Microgravity</i>	
30.	E. Dunlop <i>Mass Bioreactor</i>	
31.	S. Smith <i>Bone Mineral Measurements Using Dual-Photon Absorptiometry</i>	
32.	K. Soliman <i>Clinical Use of Metaplastic Neurological Differentiation of Chromaffin Cells Under Microgravity</i>	
	Open Discussion: L. Milov, Facilitator .....	44
SESSION VII	FACILITATOR SUMMARIES AND ATTENDEE INPUT FOR FUTURE EXPERIMENTS IN SPACE .....	47
	Session Summaries .....	47
	Open Discussion - Recommendations for Future Experiments .....	57
	CONFERENCE PAPERS .....	63
	Fundamental Results from Microgravity Cell Experiments with Possible Commercial Applications .....	65
	C.M. Winget, T.N. Fast, W.E. Hinds, R.L. Schaefer, and P.X. Callahan	
	The Pituitary Growth Hormone Cell in Space .....	71
	W.C. Hymer and R. Grindeland	

Response of Lymphocytes to a Mitogenic Stimulus During Spaceflight .....	77
G. Sonnenfeld	
Polarity Establishment, Morphogenesis and Cultured Plant Cells in Space .....	87
A.D. Krikorian	
The Sensory Transduction Pathways in Bacterial Chemotaxis .....	97
B.L. Taylor	
Physical Phenomena and the Microgravity Response .....	103
P. Todd	
How to Detect when Cells in Space Perceive Gravity .....	117
T. Björkman	
Effects of Microgravity on Growth Hormone Concentration and Distribution in Plants .....	121
R.S. Bandurski, A. Schulze, P. Jensen, and M. Desrosiers	
Gravity Receptors and Responses .....	133
A.H. Brown	
Free Swimming Organisms: Microgravity as an Investigative Tool .....	139
J.O. Kessler	
Gravitropism in Plants: Hydraulics and Wall Growth Properties of Responding Cells .....	153
D.J. Cosgrove	
Gravity and Animal Embryos .....	157
L.M. Wiley	
Human Factors Issues in Performing Life Science Experiments in a 0-g Environment .....	161
W. Gonzalez	
Do the Design Concepts Used for the Space Flight Hardware Directly Affect Cell Structure and/or Cell Function Ground Based Simulations .....	167
D.K. Chapman	
Model System Studies with a Phase Separated Membrane Bioreactor .....	177
G.R. Petersen, P.K. Seshan, and E.H. Dunlop	
Design Challenges for Space Bioreactors .....	187
P.K. Seshan and G.R. Petersen	
Fermentation and Oxygen Transfer in Microgravity .....	207
E.H. Dunlop	

Countermeasures to Microgravity .....	213
M.W. Luttgies	
Bone Mineral Measurement Using Dual Energy X-Ray Densitometry .....	221
S.W. Smith	
PRESENTATION VIEWGRAPHS .....	225
Instrumentation: The Additional Factor that Affects Microgravity Bioscience Experiments .....	227
P.X. Callahan	
Limitations on Science Due to Mission Constraints .....	237
R.W. Ballard	
Mission Requirements and Constraints on Experiment Hardware .....	243
J. Lashbrook	
Commercial Life Science Working Group .....	263
L.A. Milov	
CONCLUSIONS/CLOSING REMARKS .....	285
R.S. Bandurski and P. Todd	
CONFERENCE DEDICATIONS .....	287
George W. Nace by K. Souza	
Per F. Scholander by R. Bandurski	
ATTACHMENTS .....	289
A. CONFERENCE PARTICIPANTS.....	291
B. CELL RESEARCH EXPERIMENTS (FLOWN/PLANNED).....	297
C. CELL RESEARCH HARDWARE/FACILITIES (FLOWN/PLANNED/EXISTING).....	307
D. REFERENCES.....	315
List of References for Attachment B	
Suggested Readings	

## CELLS IN SPACE-II CONFERENCE EXECUTIVE SUMMARY

Over the past 13 years several meetings and workshops have been conducted to discuss the suitability of cells as subjects in microgravity experiments. This summary describes a conference entitled Cells in Space, which was held from October 31 through November 4, 1988, in San Juan Bautista, California. The conference, a sequel to a meeting held at NASA/Ames Research Center in 1975, was co-organized by the Space Life Sciences Payloads Office (SLSPO) and the External Relations Office, both at NASA Ames Research Center (ARC). It was sponsored by the External Relations Office, NASA Ames Research Center and the Life Sciences Division, NASA Headquarters, and funding for the conference was provided by the Office of Commercial Programs at NASA Headquarters.

An early attempt at culturing cells under microgravity conditions on Skylab was reported by Montgomery in 1977.<sup>1</sup> Montgomery examined human embryonic lung cells which were cultured for 1 to 59 days in spaceflight for modifications unique to microgravity. After a comparison of growth curves, DNA microspectrophotometry, phase microscopy and ultrastructure, he asserted that, within the confines of his experimental design, no alterations in cells resulted from exposure to a microgravity environment when compared to ground-based cultures. He did note however that the space-cultured cells consumed significantly less glucose than cells in control cultures. This observation served to support the hypothesis of Nace who proposed in 1983<sup>2</sup> that, under microgravity conditions, less energy should be required by the cell to maintain positional homeostasis. In fact, Nace's torsional model of gravitational effects induced space biologists to include biophysical phenomena as factors in their analysis of experimental results.

The Cells in Space-II Conference utilized the larger base of flight data now available to reevaluate the rationale for and conduct of cell research in space. Results from microgravity experiments, such as the impaired secretion of growth hormone from rat pituitary cells, the stimulated proliferation of *Paramecium aurelia*, and the inhibited mitogenic response of lymphocytes, need to be examined in terms of possible biophysical and hardware influences on the cell and the design of adequate experiment controls.

The objective of the Cells in Space-II Conference was to focus on three facets of cell experimentation: i) the biophysics of the cell with respect to the potential physical effects of g-unloading on the cell, and how physical effects relate to the potential biological responses of the cell; ii) the requirements for generic (common) hardware which might support "microgravity investigations" on cells; and iii) the potential collaboration of university, government and industry for development of such studies in space.

To accomplish these goals, the conference was divided into seven sessions.

Sessions I-VI addressed a specific topic related to cell experiments in space. Experts from a variety of disciplines (biophysics, biochemistry, cell biology, industrial applications) gave presentations in each

---

<sup>1</sup>Montgomery, P., et al. The response of single human cells to zero-gravity. In: Biomedical Results from Skylab, NASA SP-377, NASA Johnson Space Center. R.S. Johnstone & L.F. Dietlein, eds., 1977.

<sup>2</sup>Nace, G. Gravity and the positional homeostasis of the Cell. *Advances in Space Research*. 3(9):159-168, 1983.

of the sessions. The information presented ranged from the results of cell experiments which have flown to discussions of biophysical phenomena, transduction mechanisms, hardware design, mission constraints and commercial applications. The conference attendees actively engaged in follow-on discussions moderated by a Facilitator assigned to each session. These discussions focused on the presented material as well as the three central issues of the conference.

In Session VII, the Facilitators for Sessions I-VI each presented their session summaries with recommendations related to the conference topics. The Chief of the Flight Payloads Office at NASA Ames Research Center acted as Facilitator for this final session. Major portions of these discussions are included in this report following the abstracts of presentations for each session.

The following summary represents the conclusions and recommendations from the Cells in Space-II Conference.

1. Gravity does affect metabolism at the cellular level.
  - a. This conclusion, drawn particularly from discussions held during Session I, was based upon the results obtained from three experimental systems. Each of these systems has been studied in space two or more times and included an on-board centrifuge to provide a simultaneous 1-g control.
  - b. These experiments underscored the essential requirement for on-board 1-g controls.
  - c. Although opportunities to repeat spaceflight experiments are scarce, each flight experiment should be subjected to confirmation. This requirement is particularly important when dealing with experiments that might have a profound effect upon our understanding of the effects of gravity upon living systems.
2. Clinostat experiments are an essential adjunct to flight experiments.
  - a. The clinostat serves to make the gravity stimulus symmetric and can provide critical preliminary data on gravitational influences. Ground-based studies therefore should be fully utilized. They, however, do not substitute for microgravity experiments.
  - b. Clarification of clinostat terminology is necessary (fast vs. slow rotating clinostats, vertical vs. horizontal, etc.) in order to understand and interpret clinostat experiments.
3. Terms used in gravitational biology need to be clearly defined.
  - a. The study of the biological effects of inertial acceleration as a continuous variable from 0 to 1 g and upward is a more clearly defined activity than the study of "effects of microgravity."
  - b. Descriptions of the exposure to inertial accelerations <1 g require an unambiguous consensus term, such as "g-unloading," "hypogravity," etc.



- c. The baseline or “standard” condition for terrestrial organisms corresponds to 1 g, which is not the origin of the inertial acceleration scale.
4. The effects of gravity must be understood at the cellular and even molecular level. Since the gravity stimulus can affect metabolism at the cellular level, it is important to look for targets at the cellular organelle level. Important targets appear to be the cytoskeleton, cell to cell communication channels and metabolic pool sizes.
5. Cells in suspension may respond differently to gravity in comparison to a monolayer growth of cells attached to some substrate or fixed in solid tissue. Thus, experiments in cell biology must examine cells in tissues and monolayer cultures as well as cells grown in suspension.
6. Development of bioreactors for space studies should continue. The bioreactor will provide important opportunities to study the effects of gravity on cultures of mammalian, plant and microbial cells under carefully controlled conditions and to study large numbers of cells after many division cycles.
7. Generic hardware development should be considered as a means to reduce mission costs and to facilitate experimentation. Flight hardware may be considered to exist in four categories of development.
  - a. General-purpose hardware would be complementary to normal commercially-developed laboratory hardware and would provide an adequate laboratory environment for investigations.
  - b. User-specific hardware, while often times highly specific, should be autonomous if necessary modular if possible
  - c. Equipment which utilizes the inherent resources of the spaceflight environment, i.e., vacuum, light, low temperature and dust-free environment, should be given enhanced consideration.
  - d. Major pieces of equipment which require early development such as magnetic resonance spectroscopy (both image and probe), flow and image cytometry and specific microprobes.
8. The potential for commercial applications in space exists as evidenced by work in protein crystal growth and pharmaceuticals. There also exists a potential for the utilization of the low g environment and its effects on biological processes (including those at the cellular level) which warrants additional study.

## FOREWORD

In 1975, a NASA-sponsored Cells in Space Workshop was held to discuss the rationale for using cells as viable experimental subjects in space. While the workshop was well-attended and fruitful, a report was never issued. In addition, a Microbial Developmental Working Group convened in Arlington, Virginia, in May 1984, and the results were included in the report produced from the NASA Developmental Biology Workshop.<sup>3</sup>

In February, 1986, a Cells in Space-I Conference was convened with the more limited goal of addressing the experimental design and implementation of currently manifested cells experiments on Spacelab and the culture hardware to support these experiments. This conference (I) was also fruitful, and resulted in a report that was given limited distribution.

With the resumption of Spacelab flights, and with data now available from various space flight experiments subsequent to the 1975 meeting, it was deemed propitious to hold another conference, the subject of this report, Cells in Space-II Conference.

This conference was co-organized by Dr. Charles M. Winget, Science Operations Branch of the Space Life Sciences Payloads Office, NASA Ames Research Center, Charles C. Kubokawa, External Relations Office, NASA Ames Research Center, and Dr. Thomas N. Fast, Santa Clara University; sponsored by Laurance A. Miloy, Chief, External Relations Office, NASA Ames Research Center, and Dr. William T. Gilbreath, Life Sciences Division, NASA Headquarters; and funded primarily by the Office of Commercial Programs, James T. Rose, Assistant Administrator, NASA Headquarters. It was held October 31 through November 4, 1988, at the Saint Francis Retreat in San Juan Bautista, California. Co-chairmen of the conference were Dr. Robert Bandurski of Michigan State University and Dr. Paul Todd of the Center for Chemical Engineering, Boulder, Colorado.

Paul X. Callahan, Chief  
Science Operations Branch, Space Life Sciences Payloads Office, Ames Research Center

---

<sup>3</sup>Souza, K.A. and T.W. Halstead. NASA Developmental Biology Workshop, Arlington, Virginia, May 1984. NASA Technical Memorandum 86756, Life Sciences Division, NASA Ames Research Center, Moffett Field, CA, 1984.

## BACKGROUND AND GOALS

The objective of the conference was to identify the physical, biological and experiment-related phenomena in microgravity which must be understood in order to conduct basic cell research in space. In the process of elucidating these factors, the conference examined the types of investigations and data, the test samples and specimens, and the criteria which must underlie the design of generic hardware for cell culture studies.

Presentations were made by a number of experts, representing a variety of fields (biophysics, biochemistry, cell biology, industrial applications, etc.), in an effort to address three major topics of the conference:

### 1. The Cell as a Model for Investigating the Effects of Microgravity on Biological Systems.

During the three decades of life sciences research in space, many biological experiments that have flown used culture techniques to study the effects of microgravity on living systems. However, both within and outside of the life sciences community, there is some question as to whether the cell (or any one of a number of subcellular components) is an appropriate end organ for sensing (or responding biologically to) gravity and, thus, if it has the potential to be affected by a microgravity environment. The first goal of the conference was to examine the cell from both a physical and biological standpoint to identify, theoretically and/or pragmatically, cellular components which might react to gravity/microgravity, and to theorize on the nature of this reaction in an attempt to elucidate areas of potentially fruitful research. The conference was organized and structured on the premise that these areas of potentially fruitful research will better demonstrate phenomena which have been observed in earlier experiments, will make use of our current understanding of cell structure and function, and will clearly define physical phenomena within the cell.

### 2. The Development of Generic Hardware to Support These Investigations.

Some of the questions about cell function during space flight can be addressed with the use of small volume, light-weight support equipment which uses fewer resources than those necessary to maintain small mammals or crop plants. The expenditure of extensive resources has frequently been necessary to flight-certify hardware for planned microgravity experiments. Flight-certification ensures that hardware meets mission-imposed safety requirements, constrains the use of spacecraft resources and accommodates one-of-a-kind science requirements without compromising the intended science. While high experiment costs were not unexpected in the fledgling period of the life sciences flight program, the expense of future flight experiments will have to be reduced to take advantage of increased opportunities for microgravity experiments. One mechanism that might lead to lowered costs for flight experiments could be the development of generic flight hardware which would relieve the burdensome and expensive task of qualifying new flight hardware. The second goal of this conference was to evaluate the potential development of generic hardware for culture equipment, support equipment, and analytical equipment.

PRECEDING PAGE BLANK NOT FILMED

### 3. The Potential for Commercial Involvement in Microgravity Cell Experiments.

An additional potential means for increasing interest in and for reducing costs of cell research in the microgravity environment is to involve the commercial sector. The third goal of this conference was to stimulate interest on the part of the commercial sector by including a session on concepts for the development of potentially commercial products from microgravity research, to allow interchange among investigators, NASA management and the commercial sector.

The conference was divided into seven sessions.

Sessions I-VI addressed a specific topic related to cell experiments in space. Experts from a variety of disciplines (biophysics, biochemistry, cell biology, industrial applications) gave presentations in each of the sessions. The information presented ranged from the results of cell experiments which have flown to discussions of biophysical phenomena, transduction mechanisms, hardware design, mission constraints and commercial applications. The conference attendees actively engaged in follow-on discussions moderated by a Facilitator assigned to each session. These discussions focused on the presented material as well as the three central issues of the conference.

In Session VII, the Facilitators for Sessions I-VI each presented their session summaries with recommendations related to the conference topics. The Chief of the Flight Payloads Office at NASA Ames Research Center acted as Facilitator for this final session. Major portions of these discussions are included in this report following the abstracts of presentations for each session.

The Cells in Space-II Conference Committee extends its appreciation to James T. Rose, Office of Commercial Programs, NASA Headquarters, for his funding and support of this conference. The Committee is also greatly indebted to Ms. Shirley Guilbert, Lockheed Engineering and Science Company, for making the meeting arrangements and for coordinating efforts to produce this publication.

# CONFERENCE PROGRAM

## OPENING REMARKS

### Co-Chairmen

*Robert S. Bandurski, Dept. of Botany, Michigan State University*

The topics covered in this conference address three areas of space exploration. The first topic examines the physics of gravity detection, or, how *do* we orient ourselves to a gravity vector in view of the fact that the potential energy of a molecule associated with a gravitational field is small relative to thermal energy,  $kT$ . The second area examines spaceflight equipment. We have entered a new era in flight hardware where we must begin to address the factors which could compromise the science. The final area addressed is the commercial utility of space. While nationalism was the initial driver for investigations in space, the goal of NASA has shifted to basic science exploration and development of related commercial opportunities.

*Paul Todd, Center for Chemical Engineering, National Institute of Standards & Technology, Boulder, CO*

Space was initially thought of as a potentially dangerous place, the safety of which had to be tested prior to manned spaceflight. To evaluate safety, experiments were conducted with relevant materials, such as animals and cells. In this post-Skylab period, safety in space is now better understood, and we are ready to focus on basic scientific questions and on the use of microgravity as a tool in gravitational biology. The conference will reevaluate the use of cells as appropriate living systems for this purpose.



**ABSTRACTS/SUMMARIES OF ORAL PRESENTATIONS**

## SESSION I DOES MICROGRAVITY AFFECT CELL STRUCTURE AND/OR CELL FUNCTION?

This session focused on results of *in vivo* and *in vitro* exposure of cells to microgravity conditions and addressed whether the changes observed in cell activity were the results of microgravity.

Presenters: C. Winget, W. Hymer, G. Sonnenfeld, A. Krikorian  
Facilitator: A. Cogoli

### 1. Fundamental Results from Microgravity Cell Experiments with Possible Commercial Applications

Charles M. Winget<sup>1</sup>, Thomas N. Fast<sup>2</sup>, William Hinds<sup>3</sup>, and Ronald Schaefer<sup>3</sup>,  
<sup>1</sup>Space Life Sciences Payloads Office, <sup>2</sup>University of Santa Clara, <sup>3</sup>Lockheed Engineering & Sciences Company, NASA Ames Research Center, Mountain View, CA

This article summarizes the major milestones for experimental cell biology studies that have been conducted in the upper layers of the atmosphere and in outer space by the Soviet Union and the United States for more than thirty-five years. The goals of these studies have changed, as increased knowledge concerning the medium of outer space and the practical needs of the conquest of space have presented new problems to be faced by science and humankind. We will discuss factors which will be presented in greater detail by others at this conference. In planning and conducting microgravity experiments, there are some important prerequisites. These prerequisites are the understanding of flight hardware as a physical unit, a complete knowledge of its operation, the range of its capabilities, the anticipation of problems that may occur, and the results obtained from previous microgravity and ground-based experiments. Data from previous microgravity experiments must be used in the design of hardware for production of commercial products in space.

### 2. Cell Secretion in Microgravity

Wesley Hymer, Dept. Molecular and Cellular Biology, Pennsylvania State University, 401 Altahouse, University Park, PA 16802

Growth hormone (GH), produced and secreted from specialized cells in the pituitary gland, controls the metabolism of protein, fat and carbohydrate. It is also probably involved in the regulation of proper function of bone, muscle and immune systems. The behavior of the GH cell "system" has been studied by flying either isolated pituitary cells or live rats. In the latter case, pituitary GH cells are prepared on return to earth and then either transplanted into hypophysectomized rats or placed into cell culture so that function of GH cells *in vivo* vs. *in vitro* can be compared. The results from three flights to date (STS-8, 1983; SL-3, 1985; Cosmos 1887, 1987) established that the ability of GH cells to release hormone, on return to earth, is compromised. The mechanism(s) responsible for this attenuation response is unknown. However, the data are sufficiently positive to indicate that the nature of the secretory defect resides directly within the GH cells.



### **3. Response of Lymphocytes to a Mitogenic Stimulus during Space Flight**

Gerald Sonnenfeld, Department of Microbiology and Immunology and Department of Oral Health, Schools of Medicine and Dentistry, University of Louisville, Louisville, KY 40292

Several studies have been carried out that demonstrate that immunological activities of lymphocytes can be affected by space flight or by procedures that attempt to simulate some aspect of weightlessness. Many studies have been carried out to determine whether space flight can affect the ability of lymphocytes to mount a blastogenic response to mitogens. The results of these studies indicate that lymphocyte blastogenic responsiveness to mitogens was impaired when lymphocytes were placed in culture and exposed to mitogens during space flight. Similar results were observed when cultures of lymphocytes were prepared on the ground from samples obtained from astronauts or animals immediately after space flight. Also, most models for hypogravity have shown similar effects. When lymphocytes from Soviet cosmonauts were cultured and exposed to Newcastle disease virus during space flight, the production of interferon, an important immunoregulatory substance, was greatly enhanced. However, when cells were obtained from the same cosmonauts or immediately after return to earth, interferon production was inhibited severely. In rodent studies, lymphocytes from rats flown in Space Shuttle SL-3 were placed into cultures immediately upon return of the rats to earth, the cells were challenged with mitogen, and interferon production was inhibited greatly, but production of another biologically important immunoregulatory substance, interleukin-3, was unaffected. The mechanism of the effects of space flight on immunological processes remains to be established.

### **4. Polarity Establishment and Morphogenesis in Cultured Plant Cells in Space**

Abraham D. Krikorian, Department of Biochemistry, State University of New York at Stony Brook, Stony Brook, NY 11794-5215

Plant development entails an orderly progression of cellular events both in terms of time and geometry (dimensional space). There is only limited and circumstantial evidence that in the controlled environment of the higher plant embryo sac that gravity may play a role in embryo development. But *in vitro* systems involving totipotent or morphogenetically competent cells present other conditions since there is no such controlled environment other than that extant in the genetic program of the test system. Here, unless the developing cells and proembryos are maintained in an environment of strict balance of nutritional and other factors, there is a chance (in the case of over-enrichment) of massive proliferation of undifferentiated tissue being formed or (in the case of impoverishment) a great chance that proper growth or differentiation might not occur. Between the extremes lies the optimum set of gradients for the differentiation of tissues and organs to occur. In short, the plasticity of development from *in vitro* systems provides an ideal tool to probe environmental and nutritional and interactive impact. Work done at Stony Brook in connection with Kosmos 782 and 1129 using totipotent carrot cells which could undergo somatic embryo formation showed that while the broad events of asexual embryogenesis could and did occur (cf. Science 200, 67, (1978); Life Sciences and Space Research 17, 271 (1979); Adv. Space Res. 1, 117

(1981)), the transition from one stage to another was slowed down. Specifically, at 0 g, a greater proportion of embryos were at "stage 2" and fewer embryos had progressed to stages 3 or 4 ( $p < .001!$ )-(unpublished because unrepeated). The cell system used for the Kosmos experiments involved the generation of so-called competent cells, their induction on Earth to produce competent pro-embryonic units, and their subsequent exposure to Space conditions so as to evaluate their capability of expressing their capacity to form somatic embryos. The normalcy of the developmental pathway of cells to proembryos and to later stages of embryogeny could thus be scored. Similarly, the broad temporal aspects could be traced. The experimental design was, however, not optimal insofar as the temporal aspects were concerned (there was no onboard fixation), neither was a centrifuge available on the 1129 flight. A much improved assay system for carrot is in the process of being developed and will provide a much better opportunity to get a definitive answer to the question as to whether development of plant cells in Space can occur with acceptable morphogenetic fidelity. Supported by NASA "Cells, Embryos and Development in Space."

## OPEN DISCUSSION - SESSION I

A. Cogoli, representing the European Space Agency (ESA), participated in the Conference as the Facilitator for the first session. He remarked that the many results presented in the ESA report, stemming from Biorack experiments on D-1, clearly established that space does influence cell structure and function. The issues to address now are the mechanism and the purpose for such an effect. Cogoli opened the discussion by reminding the group that since experiments were conducted on both whole organisms (humans or animals) and single cells in space, it was important to distinguish where the effects were manifested when discussing the effects of microgravity.

R. Gruener complemented W. Hymer on his fine presentation of results but commented that he did not address the controls for his experiment. Controls would help determine whether the cells or animals that were flown were stressed in such a way that can be mimicked on earth. Such a comparison would test the possibility that a generalized stress, rather than microgravity, was responsible for results. Gruener emphasized the importance of keeping the stress factor in mind. Hymer reported that the classic indicators of stress (adrenal gland size, blood glucocorticoids) were measured in SL3 rats. It was his feeling that animals were not stressed. P. Callahan indicated, in addition, that there were synchronous and vivarium control rats. In no instance was stress indicated in these controls as, for example, in liver enzyme measurements.

A. Cogoli took issue with the cell-cell interaction point proposed by G. Sonnenfeld (effects of microgravity may be the result of impaired cell-cell interaction). Cogoli observed an aggregation of lymphocytes after a three-day incubation at zero g. These aggregates contained cells labelled with thymidine, indicating activated cells (blastogenesis). Cogoli did not think it was cell-cell interaction that was defective but another effect of microgravity. Sonnenfeld agreed that cells could interact, as Cogoli showed in his slide of aggregates, but cell contact did not necessarily mean that cells were interacting appropriately.

J. Kessler brought the discussion back to the question posed by the session Facilitator, i.e., are cells sensitive to microgravity? Kessler wondered what was meant by the word "sensitive." Sensitivity could refer to either an altered production of chemicals or to an altered response to chemicals. Sensitivity could also refer to an induction of or reaction to morphological changes. Sensitivity could be the response of individual cells or the collective response of cells. "Sensitivity" needed to be defined in this context of microgravity effects. He referred to W. Hymer whose presentation cited examples of all types of effects but who summarized with "nobody knows."

W. Hymer emphasized that, because investigators cannot guarantee the perfect execution of an experiment, or its repeatability, it cannot be concluded that a lack of gravity was responsible for the resulting data. P. Callahan rephrased Hymer's "nobody knows" in another context: Results suggest a microgravity effect but until interactions and mechanisms are further examined, an actual microgravity effect can not be concluded.

In the ensuing discussion, the importance of repeatability and experimental controls was reiterated.

A. Cogoli cited the Montgomery experiment which had been performed only once on Skylab, and the lymphocyte experiment which had been conducted twice by Konstantinova in the Soviet Union. He also stated that BIORACK had a 1 g centrifuge lymphocyte Control in flight. Similarly, G. Sonnenfeld stated that because his sampling size was so small, and because lymphocyte baseline data were not obtained from astronauts in the year prior to flight, the experiment which compared alterations in interferon production was not valid.

A. Krikorian related his observations of abnormal somatic plant cells grown on clinostats and suggested that clinostats may be a good model of microgravity.

R. Bandurski remarked on how the effects on cells appear deleterious while the intact organism - animals and astronauts - still survive. In response, W. Hymer stated that there was a 75% reduction in Growth Hormone measured in the cosmonauts and that additional data suggested that muscle atrophy and severe bone changes occurred. The cosmonauts would probably recover but it was more a question of time. Hymer believed that the Growth Hormone defect was related to the packaging of molecules; he added that A. Krikorian's observation that colchicine can mimic the effect of spaceflight (the rounding up of apical meristematic plant cells) should have "sparked" some thoughts on a microtubule effect of microgravity.

In a discussion of effects exclusive of microgravity, J. Kessler posed a question about the effect of hydrostatic pressure. He noted that antiorthostatic tilt could result in different hydrostatic pressure as well as the cyclical changes in hydrostatic pressure induced by clinostatting. A. Cogoli offered this experimental observation: lymphocyte exposure to 10 g resulted in higher activation of both B and T cells (Con A known to affect only T cells). When lymphocytes were cultured at 1 g with a higher column of liquid, he saw no effect of hydrostatic pressure. G. Sonnenfeld, also, reminded the group that fluid shifts can also induce changes in hydrostatic pressure further suggesting the probable involvement of multiple factors.

A. Cogoli related his use of stratospheric balloon flight to test the effects of cosmic radiation. The exposure to cosmic radiation in a balloon at 40 km is similar to the exposure in spaceflight without having to leave the 1 g environment. He strongly recommended the use of balloons (1 g) and sounding rockets (5-10 min, 0 g) to answer preliminary technological and experimental questions.

R. Bandurski commented that in microgravity there are transport rate effects, unstirred boundary layer problems or problems with gas transport. These biophysical factors cannot be accounted for by 1 g centrifuge controls on board. Many of the effects seen in cell culture may, in fact, be induced by boundary layer effects. Subsequently, J. Kessler stated that an entirely filled, no free surface, system would prevent the surface tension-driven convection currents which could introduce mixing effects. He suggested that, for cultures requiring gas exchange, a membrane could act as a stiff surface cover for the fluid while still allowing gas exchange.

K. Soliman brought up the issue of microtubules. The observed spaceflight effect on mitosis and cellular division could be attributed to direct effects on microtubules. He felt that not enough attention has been paid to microtubule function in zero g. A. Cogoli pointed out a problem with glutaraldehyde in spaceflight for cell fixation. R. Bandurski related to the audience the conclusion of Thomas Thompson, who stated that the rigidity of membranes and microtubules precludes their bending due to 1 g forces. In reply, T. Björkman commented that many subcellular structures, such as the mitotic apparatus, are large enough to be moved by gravity well above thermal noise. P. Todd presented a crucial point in stating that microtubules are not static structures in the living cell but are engaged in self-assembly/disassembly. Thus, this progression of movement renders microtubule-driven organelle motions likely to be influenced by gravity. A. Cogoli agreed that a dynamic system (such as the activation in three days of resting lymphocytes) can be affected by gravity at each stage of this irreversible and complex process. He proposed that cells evolved in the presence of gravity and that it is worthwhile to examine the effects of zero g on cellular function.

A. Krikorian emphasized further that cellular processes were inevitably affected by zero g. Patterning and positioning of cells in root material, for example, are temporally affected and he asserted that one could predict spaceflight effects to become more pronounced over time.

As for the issue of physical and mechanical forces being influenced by, or interacting with, microgravity, R. Bandurski did not feel that NASA had the programs by which investigators could propose experiments directed toward addressing these specific issues. In reply, P. Callahan hoped that in the publication of a Technical Memorandum on this conference NASA will become aware of the basic questions which need to be addressed and support those projects financially.

In a comparison of ESA and NASA, A. Cogoli noted that the Europeans historically focussed on basic science questions (the development of BIORACK) since they had no independent manned program, while the US and USSR were forced to develop the human-related safety or commercial aspect of space. In the end, though, the major "spin-offs" come from basic research.

Some final comments as the session closed: i) data must be collected with respect to pressure effects ii) clinostat effects must be clearly defined, and iii) equilibrium and thermodynamic issues must be formally addressed.

## SESSION II BIOPHYSICAL PHENOMENA AND THE GRAVITY RESPONSE

The presenters for this session discussed the potential effect of microgravity on cells from the perspective of biophysics and bioenergetics.

Presenters: B. Taylor, P. Todd, D. Clifford, T. Björkman, R. Bandurski  
Facilitator: P. Callahan

### 5. The Sensory Transduction Pathways in Bacterial Chemotaxis

Barry L. Taylor, Dept. of Microbiology, School of Medicine, Loma Linda University, Loma Linda, CA 92350

Bacterial chemotaxis is a useful model for investigating in molecular detail the behavioral response of cells to changes in their environment. Peritrichously flagellated bacteria such as *Escherichia coli* and *Salmonella typhimurium* swim by rotating helical flagella in a counterclockwise direction. If flagellar rotation is briefly reversed, the bacteria tumble and change the direction of swimming. The bacteria continuously sample the environment and use a temporal sensing mechanism to compare the present and immediate past environments. If the present environment is more favorable, the bacteria suppress tumbling so that they continue swimming in the favorable direction. If the present environment is less favorable, the probability of tumbling increases thereby improving the chances of swimming to a more favorable environment. Bacteria respond to a broad range of stimuli including changes in temperature, oxygen concentration, pH and osmotic strength. They are attracted to potential sources of nutrition such as sugars and amino acids and are repelled by other chemicals.

In the methylation-dependent pathways for sensory transduction and adaptation in *E. coli* and *S. typhimurium*, chemoeffectors bind to transducing proteins that span the plasma membrane. The transducing proteins are postulated to control the rate of autophosphorylation of the CheA protein, which in turn phosphorylates the CheY protein. The phospho-CheY protein binds to the switch on the flagellar motor and is the signal for clockwise rotation of the motor. Adaptation to an attractant is achieved by increasing methylation of the transducing protein until the attractant stimulus is cancelled. Responses to oxygen and certain sugars involve methylation-independent pathways in which adaptation occurs without methylation of a transducing protein. Taxis toward oxygen is mediated by the electron transport system and changes in the proton motive force. At high concentrations, oxygen is also a repellent. Recent studies have shown that the methylation-independent pathway converges with the methylation-dependent pathway at or before the CheA protein.

### 6. Physical Phenomena and the Microgravity Response

Paul Todd, Center for Chemical Engineering 583.10, National Institute of Standards and Technology, 325 Broadway, Boulder, CO 80303, USA

The living biological cell is not a sack of Newtonian fluid containing systems of chemical reactions at equilibrium. It is a kinetically-driven system, not a thermodynamically-driven system. While the cell as a whole might be considered isothermal, at the scale of individual macromolecular events there is heat generated, and presumably sharp thermal gradients exist at the submicron level. Basic physical phenomena to be considered when exploring

the cell's response to inertial acceleration include particle sedimentation, solutal convection, thermal convection, electrokinetics, motility, cytoskeletal work and hydrostatic pressure. Protein crystal growth experiments, for example, illustrate the profound effects of convection currents on macromolecular assembly. Reaction kinetics in the cell vary all the way from diffusion-limited (very fast) to life-time limited (very slow). Transport processes vary from free diffusion, to facilitated and active transmembrane transport, to contractile-protein-driven motility, to crystalline immobilization. At least four physical states of matter (phases) exist in the cell: aqueous, non-aqueous, solid, and immiscible-aqueous. Levels of order vary from crystalline to free solution. The relative volumes of these states profoundly influence the cell's response to inertial acceleration. Such subcellular phenomena as stretch-receptor activation, microtubule re-assembly, synaptic junction formation, chemotactic receptor activation, and statolith sedimentation have been studied recently with respect to both their basic mechanisms and their responsiveness to inertial acceleration. From such studies a widespread role of cytoskeletal organization is becoming apparent.

## 7. Electrophoresis and Microgravity

Don W. Clifford, McDonnell Douglas Astronautics Company

A space-qualified continuous flow electrophoresis system was developed by McDonnell Douglas for the purpose of separating large quantities of biological materials for both research and therapeutic purposes. Systems developed earlier for ground operation suffered from limitations on sample concentration and separation quality or resolution. A modified unit was developed for operation in the middeck of the Space Shuttle Orbiter which overcame these limitations during microgravity operation.

Buffer flows upward in a 120-cm long flow chamber which is 6 cm wide and 1.5 mm thick in the laboratory version, and 16 cm wide and 30 mm thick in the microgravity version. The processed material is collected in 197 fractions spanning the 16 mm width at the top of the chamber. The separation chamber is cooled by electrode buffer flowing through front and back cooling chambers, which are also electrode chambers, which in turn were controlled by the Orbiter's cooling loop.

The middeck unit has flown on seven shuttle flights, the first four of which were experimental evaluations. The last three were preprocessing flights which used a production version of the system operated by a company payload specialist. During the first four flights, the effects of microgravity were evaluated, using various protein solutions, polystyrene latex beads, and, on flight STS-8, a selection of mammalian cells. In the microgravity environment, sedimentation and buoyancy-driven convection currents were also resulting in much higher throughput rates (718 x ground rate) without compromising resolution.

The cell experiments on STS-8 included dog pancreas cells, rat pituitary cells and human embryonic kidney cells (1). A low-conductivity buffer, triethanolamine-potassium acetate buffer, pH 7.25, 296 mOsm/L flowed through the chamber at 20 ml/min. Cells were injected into the buffer at the bottom of the chamber using a 4 ml/hr infusion pump. Cells were suspended in carrier buffer at 4 ° C before injection. The separated fractions were collected in 15 ml latex bags containing 3 ml serum, medium and antibiotics, and stored at 4 ° C until landing.

The most significant problems encountered were bacterial contamination and reduced quantities of cells recovered due to difficulties with cell clumping

in the injection pump. The pancreas cells did not separate on orbit due to damage to the cells resulting from unplanned cryopreservation prior to flight. The pituitary and kidney cells were recovered and showed significant subpopulation discriminators in expressed product.

(1) W.C. Hymer, et al. 1987. Continuous Flow Electrophoretic Separation of Proteins and Cells from Mammalian Tissues." Cell Biophysics. 10, 62-85.

## **8. How to Detect When Cells in Space Perceive Gravity**

Thomas Björkman, Department of Botany, KB-15, University of Washington, Seattle, WA 98195

It is useful to be able to measure when and whether cells detect gravity during spaceflights. For studying gravitational physiology, gravity perception is the response the experimentalist needs to measure. Also, for growing plants in space, plant cells may have a non-directional requirement for gravity as a developmental cue. The main goals of spaceflight experiments in which gravity perception would be measured are to determine the properties of the gravity receptor and how it is activated, and to determine fundamental characteristics of the signal generated.

Measuring gravitropic curvature. The main practical difficulty with measuring gravity sensing in space is that we cannot measure gravity sensing with certainty on earth. Almost all experiments measure gravitropic curvature.

Reciprocity and intermittent stimulation are measurements which have been made to some degree on earth using clinostatting, but which would provide clearer results if done with microgravity rather than clinostatting. These would be important uses of the space laboratory for determining the nature of gravity sensing in plants.

Electrical measures of gravity sensing. Those techniques which do not use gravitropic curvature to measure gravity sensing are electrophysiological. The vibrating probe would be somewhat easier to adapt to space conditions than the intracellular microelectrode because it can be positioned with less precision. Ideally, a non-invasive technique would be best suited if an appropriate measure could be developed.

Thus, the effect of microgravity on cultured cells is more likely to be by large-scale physical events than gravity sensing in the culture cells. I do not expect that it will be necessary to determine whether individual cultured cells perceive gravity unless cells grow abnormally even after the obvious microgravity effects on the culture as a whole can be ruled out as the cause.

## **9. Targets for the Gravity Stimulus: Voltage-gated Channels**

Robert. S. Bandurski, Aga Schulza and Mark Desrosiers, Botany and Plant Pathology Department, Michigan State University, East Lansing, Michigan 48824-1312

We are attempting to understand the perception and transduction of the gravitational stimulus at the molecular level. To do so requires a reductionist approach utilizing the simplest possible biological response to the gravity stimulus. Small seedlings of corn, (*Zea mays*) respond rapidly when moved from a vertical to a horizontal orientation growing back into a vertical orientation at a rate of 1° per minute. The growth response begins within 5 minutes after the gravity stimulus. More rapid than the growth response is a



membrane depolarization occurring within seconds after the gravity stimulus. Membrane depolarization is followed by chemical asymmetries occurring about simultaneously with the growth response. This laboratory has concentrated on the mechanism by which the gravitational stimulus is transduced into an asymmetric distribution of the growth hormone, indole-3-acetic acid (IAA). We have adduced evidence that the targets of the gravitational stimulus are the channels through which IAA moves from the vascular tissues of the plant into the surrounding cortical cells. On the basis of this evidence we developed the Potential Gating Theory which postulates: a) the gravity stimulus causes a membrane depolarization; b) the membrane depolarization opens and/or closes the transport channels between the vascular tissue and the cortical cells of the plant; c) the resultant asymmetric distribution of growth hormone results in the observed gravity-induced growth response. The theory predicts that an applied electrical potential will influence the movement of IAA and other messengers from vascular into cortical tissues and we are in the process of testing this prediction. (Supported by the Flight Program, NASA-NAG 2-362; Space Biology NAGW-97; and NSF DMB 8504231)

## OPEN DISCUSSION - SESSION II

P. Callahan, Chief of Science Operations Branch, Life Sciences Payloads Office, NASA Ames Research Center, was Facilitator for the session which addressed the biophysical and biochemical mechanisms in cells which could be the targets for microgravity effects.

Following B. Taylor's presentation on bacterial chemotaxis, he was asked to clarify further the transduction of the signal between the stimulus at the chemoreceptor and the controlling mechanism of the flagellar motor. He explained that, based on the diffusion constant, the signal was determined to be too slow to be a membrane potential or a small molecule. The signal is thought, more accurately, to be transmitted through interactions of one protein with another, resulting in protein modification. In particular, he explained that the regulation of protein methylation could occur by two approaches: by the conformational changes in the protein which rendered it more or less receptive to the methylating protein, or by the autophosphorylation of the CheA protein, which phosphorylates the methyl esterase, CheB.

In reference to bacteria which luminesce in response to stress induced by shear forces, J. Kessler queried whether the proton gradient associated with chemotaxis could be a mechanical response to shear stress, and whether the gradient could be expected to change in response to other mechanical conditions such as microgravity. B. Taylor replied that there is a possibility that conditions of microgravity can induce changes in the proton motive force which could then be responsible for transducing a behavioral response. He also confirmed that the proton motive force referred to a gradient which can be considered to act as a force.

When asked by P. Seshan if other organisms have this chemotactic trait, B. Taylor cited work currently being conducted on leukocytes, which had a more complicated transduction mechanism. K. Soliman was interested in Taylor's assumption that observed responses in his bacterial model are chemically mediated. Because the genes for chemical mediation are required in order to observe a response, Taylor asserted that the assumption is correct.

After the T. Björkman presentation on microelectrophysiology of plant cells, G. Conrad initiated a discussion on the applicability of fluorescent optical probes which are used on animal cells to measure ionic changes. Björkman cited work conducted at Berkeley which had successfully used calcium indicators for months, but he felt it could not be practically used because it would require developing a method to remove a single cell, or a small group of gravity sensing cells, from its "normal" gravity sensing milieu. Once the cells are removed, one cannot confirm their competency when measuring a response to a gravity stimulus. Conrad described a study with a group of cells activated by epifluorescence. Measurements were performed on muscle strips held in a cuvette using Quin 2 (a calcium indicator). Björkman insisted, however, that the cells are too far into the plant tissue and that extraction from the responding zone was required in order to see the fluorescence of the cells. Extraction, moreover, would preclude localization studies. P. Callahan reiterated the interest expressed in microoptical probes by commenting on the ability of some probes to look into a cell with *minimal* cell damage. R. Bandurski suggested that NMR (Nuclear Magnetic Resonance) might be the

ideal technique to apply especially if the initial response to gravity is a generation of the proton motive force.

When R. Bandurski questioned Björkman's pessimism regarding the repeatability in Sievers experiment on the redistribution of statoliths in Chara rhizoids (four positive results obtained over four years--Behrens et al. 1985. Planta. 163,p. 463.), Björkman agreed that Siever may have examined more parameters than would actually be needed in space. But he also felt that in this case, a positive result *needs* to be demonstrated with every attempt, and consequently, based upon this experiment, he remained pessimistic. A. Brown and Björkman then engaged in a discussion concerning gravity sensing as exemplified by reaction wood. Björkman stressed that this perturbation on a large scale was not the same as the gravity sensing occurring within a cell. He remarked that many things could be affected by gravity on a large scale, i.e., gravity detection was contingent upon an object's size. This detection was different from looking at the "normal" intracellular gravity sensing process.

J. Kessler complimented T. Björkman on his discussion of presentation time. Björkman had mentioned that one component of presentation time might be shear thinning (i.e., fluid was non-newtonian and its viscosity would decrease when a force was applied to it). Kessler asked if Björkman had quantitated the amount of g force required for shear thinning to stop. Referring to Björkman's graph on presentation time as a function of gravity, Kessler suggested looking at the response of presentation time to high gravity forces to prove such an effect.

A. Krikorian agreed with the point made by A. Brown regarding the lengthy time to see a response in a tree. A tree may require considerable time to grow and develop but it does not mean that gravity sensation is not immediate or not continuing. It may only signify a different morphological manifestation. Krikorian mentioned that, for the developing plant, there is a division of labor among the cells and no assigned function is fixed for a given stage of development. Krikorian suggested that some of the responses T. Björkman documented may be related to a particular stage of development or to time. Björkman concurred that it was an important point. He mentioned how the gravity sensing cells in the root caps could remain gravity sensing for hours but then later progress to become secretory cells.

A. Krikorian asked, in addition, how presentation time was affected when responses were tested under cold temperature. T. Björkman replied that it became very long but that it was consistent with a general temperature response (poor performance under temperature extremes); it was not a Q10 type of response.

P. Callahan inquired if T. Björkman had considered upsetting the relationship between sedimentation and Brownian motion by introducing just the right frequency of vibration. Callahan suggested a "pseudoeffect" of vibration from the standpoint that, for a different density of gravity sensors, its response to random shocks should simulate the same type of effects induced by Brownian motion. Björkman though it was an interesting consideration, i.e., adding another factor. The gravity sensors would be triggered more often because of the cumulative effect of sedimentation, Brownian movement and vibration. By varying any one of these factors one could judge whether the scale for distance, or for time, was correct.

R. Gruener was particularly interested in the amplification system discussed by R. Bandurski because the concentration of ion channels or of receptors also occurred in the nervous system with effector cells. Gruener has been using this observation as an index for monitoring the effects of microgravity on cells. He found that clinostat rotation nearly eradicated the communication between nerve and muscle such that receptors did not translocate to the neuromuscular junction. This observation suggested that the amplification system became attenuated or destroyed. In fact, Gruener proposed that this amplification system could be the target of the microgravity effect. A similar effect may be also observed in differentiating cells; he suggested that examination of these cells under simulated microgravity, such as clinorotation, and observations be made on whether differentiation is inhibited.

In keeping with the Conference format, the Facilitator P. Callahan queried the presenters as to whether they considered cells to be appropriate biological models to study in space. T. Björkman felt that he could study his interests using a single cell model because isolated cells cannot be proven to be competent at sensing gravity. A single cell did not produce an obvious morphological response, so he did not know how one would even go about establishing competency.

R. Bandurski was reminded of the classical experiment of Jaffe and Nuccitelli (Jaffe, L.F. and R. Nuccitelli, 1977. Electrical controls of development. Ann. Rev. Biophys. Bioeng, 6:445-476) who lined up cells in an agar gel and polarized the group as a whole - he pondered whether such a method could be employed by someone studying bacteria. B. Taylor remarked that bacterial experiments could be done in semisoft agar but that, due to the vibrations incurred during launch, he doubted whether such a system is appropriate for microgravity experiments. P. Callahan assured him that it is possible to buffer organisms against the vibrations at launch. Bandurski also wondered if a bacterial suspension could be considered as a sum of capacitors; if so, then the variation in capacitance could be measured as a function of an AC sine wave voltage. Taylor pointed out, however, that there are many transport systems linked to the proton motive force and that it would be too difficult to isolate a particular response and attribute it to a change in the proton motive force, unless it was something like aerotaxis where there is a major change in the proton motive force. In a similar vein, Bandurski noted that to induce growth in a plant "hundreds of things" must be asymmetrically distributed.

R. Gruener commented that cells must be specialized for gravity sensing before they are suitable for a gravity experiment. Gruener claimed that since all cells evolved under a constant gravity state it is not known if any cells will sense a difference in gravity, such as in space or with simulation. He continued by saying that R. Bandurski's idea of a concentration of organelles or an accumulation of proteins within a cell membrane may in itself provide a system for sensing gravity. The polarization of cilia on a bacterium would be another example of a gravity sensing system which would not normally be considered as having that function.

T. Björkman commented that the influence of gravity is a billion times too low to account for intracellular focussing, especially if you consider the extent, and the rapidity at which diffusion must occur. He concluded by saying that

it is more reasonable to attribute any aberration or change observed in parenchymal cells in microgravity to a pathological response to factors in the environment altered by microgravity rather than to a normal response to a change in a gravitational vector.

P. Todd closed the discussion by discriminating between fortuitous and a deliberate sensing of the gravity vector. He explained that while all cells may have evolved in the *presence* of 1 g, cells did not necessarily evolve the mechanisms for directly *responding* to it. However, all cells *did* evolve in the presence of Brownian motion and they have evolved methods by which to avert the chaos that Brownian motion would otherwise introduce into the cell, e.g., by the development of cytoskeletal structures and organelles. Thus, these structures became sensitive to gravity through their fortuitous development of mass, as opposed to cells which were favorably selected because they possessed necessary structures which can sense gravity. Hence, both fortuitous and deliberate responses to inertial acceleration might be expected at the cellular level.

### SESSION III GRAVITY UNLOADING - UNDERSTANDING THE INPUT AND OUTPUT MECHANISMS OF THE ORGANISM RESPONSIBLE FOR THE TRANSFORMATION OF INERTIAL ACCELERATION INTO A RESPONSE

This session examined the possible mechanisms by which microgravity exerts its effect. Presentations were based on observations made from unicellular organisms, developing embryos, differentiated cells and plant cells.

Presenters: A. Brown, J. Kessler, D. Cosgrove, J. Frangos, L. Wiley  
Facilitator: J. Duke

#### 10. Gravity Receptors and Responses

Allan H. Brown, Gravitational Plant Physiology Laboratory, Philadelphia, PA 19104

Knowing a little about plant physiology and less about other things, we shall concentrate on how plants detect, respond to, and exploit gravity. We shall have only a little to say directly about other creatures including hominids.

First, we should free ourselves from the provincial concept that gravity (or lack of it) is of interest mostly as a cause of stress to be endured or counteracted; most interesting gravitational biology is not stress physiology.

G-force stimulation is an input of environmental information. The information flow can be divided into: the initial physical event, stimulus susception; its influence on a sensor (bioaccelerometer), information perception; the transformation of that information into some form that is biologically meaningful, transduction; export of transformed information (when required) to cells and organs other than the sensor location, transport; and the final biological impact of the information, usually (not always) a growth response.

The scope of our assigned topic probably was intended to ensure focus on perception rather than on more down stream portions of the information flow. Susception is the physical act of imposing a G-force which the organism can perceive. It may be important to note that the stimulus may be gravitational or inertial; in either case susception is the same, in accordance with the basic "principle of equivalence."

Does perception require that something be moved? Yes. The perceptive G-sensor must suffer some change of position or shape. Whether we call the perturbation falling, torsion, twisting, stretching, bending, compression, displacement, stratification, acceleration, or altered momentum does not change the fact that the consequence of susception is to change something's position or shape.

Sedimentation of organelles in statocytes of most higher plants undoubtedly is related to an "early" event in the stimulus-to-response sequence. There is not yet a consensus on how stratification of protoplasmic components makes happen all that occurs down stream in the information flow sequence. Lower plants (e.g., some fungi) and some higher plants in which patently sedimentable organelles have not been found warrant more thorough examination. They appear to be "exceptions that prove (test) the rule" and may lead us to discover that other quite unexpected mechanisms of perception not only exist but even may be quite common.

The plant processes its acquired G-information and uses it normally in salubrious ways. It can add, subtract, multiply, remember, and forget. It has the capability for responding either linearly or according to other functions,

e.g., logarithmically. It seems likely that its computers are analogue devices. Much of this arithmetic ability probably operates early in the stimulus-response sequence.

The diversity of organisms' responses to G-stimulations is impressive but it seems probably that the origin of this diversity will be found in the information flow rather than in the perception phase.

Gravitropistic responses may not always be the most salient objects for study of gravitationally dependent processes. There are many well recognized (but not well understood) interactions detected as gravity modifications of other processes or paths of information flow. These deserve to be studied because they may provide not only evidence of interactions but also clues to their molecular mechanisms.

Our researchers may be exploratory and observational or they can be experimental, in which case we need to vary the environmental factor under investigation so as to affect in a controlled manner the alteratic variable G. Even an all or none (on/off) change may be of some help but the more we can vary the G-force the more interesting will be our attention to the early (perception) phase of the information flow sequence. For many objectives in gravitational physiology the researcher alters the kind of G-information our test subjects receive. These are prominent in gravitational biology experimentation. They differ chiefly in rotational diameter, rotational frequency, payload capacity, and cost of access.

## **11. Free Swimming Organisms in Microgravity**

John O. Kessler, Physics Department, University of Arizona, Tucson, AZ 85721

By unloading the force of gravity, the space microgravity environment provides a unique opportunity for simplifying and elucidating the dynamics of single cells and cell association patterns. On Earth, microorganisms are in the grip of gravitational and viscous forces. These forces, in combination with sensory stimuli, determine the average orientation of the organisms' swimming trajectories relative to the fluid environment. Eliminating gravity will simplify study of the rules which govern the summation of orienting influences. It will become possible to perform quantitative physical measurements (rather than statistical ones) of responses to stimuli, e.g., the measurement of phototactic orientation tendency in dyne-cm units! Also, by reducing or eliminating buoyant convection driven by variations in fluid density, it will be possible to study illumination, temperature gradient, and concentration gradient - mediated collective dynamics.

## **12. Gravitropism in Plants: Hydraulics and Wall Growth Properties in Responding Cells**

Daniel J. Cosgrove, Department of Biology, Pennsylvania State University

Gravitropism is the asymmetrical alteration of plant growth in response to a change in the gravity vector, with the typical result that stems grow up and roots grow down. The elucidation of this response will tell us much about how gravity exerts its morphogenetic effects on plants and how plants regulate their growth at the cellular and molecular levels. Marker studies of the gravitropic response of young cucumber seedlings show that after a lag of ten minutes the upper stem surface ceases elongation entirely and the lower surface doubles its expansion rate. These changes in cell expansion correspond to changes in water uptake, yet the hydraulic characteristics of

the cells change very little during the response. Rather, water uptake depends on wall relaxation, and its alteration during gravitropism is not yet understood, but hypotheses center around enzymatic loosening of the cell wall, with control via alteration of the ionic environment of the extracellular space. The current state of these ideas will be briefly surveyed.

### 13. Flow Effects on Osteoblasts

Kathleen M. Reich, Carol V. Gay and John A. Frangos, Departments of Chemical Engineering and Molecular and Cell Biology, The Pennsylvania State University, University Park, PA 16802

The mechanism responsible for the progressive bone loss observed in skeletal unloading due to bed rest, immobilization, and weightlessness are largely unknown. Considerable evidence suggests that the flow of extracellular fluid induced in bones by normal mechanical loading may serve as an external signal which stimulates metabolism of osteoblasts, the bone-forming cells.

During the past year, our lab has begun testing this hypothesis. Cultured rat calvarial bone cells have been characterized as osteoblasts by their morphology, their response to parathyroid hormone and their ability to form a mineralized matrix. Osteoblasts subjected to flow for 15 min. exhibited a dramatic increase in intracellular cyclic AMP levels. This demonstrates that fluid shear is a stimulus to which osteoblasts respond.

The objective of this project is to quantitate the effect of fluid shear on bone formation. Bone formation is the result of two series of events: protein matrix deposition and its mineralization. Collagen deposition will be used as a marker of extracellular matrix formation and osteocalcin production will be measured as a marker of mineralization potential. Further studies will include actual quantification of *in vitro* mineralized matrix by microincineration techniques.

If these studies demonstrate that fluid shear stress stimulates osteoblasts to produce bone matrix, our system would represent a rather versatile *in vitro* cell culture model for mechanically-induced bone formation, and would greatly facilitate pharmacological studies on the prevention of osteoporosis due to disuse and weightlessness.

### 14. Gravity and Preimplantation Development

Lynn Wiley, Division of Reproductive Biology and Medicine, University of California, Davis, CA

Out of more than 4,500 rat hours in space there has been only one experimental attempt (Cosmos 1129) at mating with an apparent absence of fertilization, implantation and subsequent development to term and parturition. Portions of this process have been successfully flown, however, including the major portion of organogenesis in the rat (Cosmos 1524). These observations show that the cellular and molecular events underlying morphogenesis and differentiation in a small mammal can proceed normally *in utero* under microgravity and other conditions encountered during short-duration flight. However, we do not know whether this situation will hold for larger mammals over several generations during extended missions that venture outside of near earth (e.g., the moon, Mars). Furthermore, we do not understand why the previous attempt at obtaining copulation, fertilization and implantation in orbit failed but may have been related to limitations of the rat habitat for



meeting the preconditions for reproductive behavior. With respect to mammalian development it is important to appreciate that fertilization and development occur internally within the female and take a long time to complete and their success will, therefore, be contingent upon the maternal response to the space environment.

One process central to development - the establishment of cell lines - is initiated prior to implantation by environmental asymmetries perceived by progenitor cells. These asymmetries appear to result from the formation of asymmetric cell-cell contacts and the concomitant development of an electrical axis across the progenitor cells. Other asymmetries have also been documented. It is not known whether any of the known asymmetries perceived by progenitor cells are influenced by gravity vectors and/or by the maternal response to microgravity and other conditions encountered in space.

### OPEN DISCUSSION - SESSION III

J. Duke, Dental Science Institute of the University of Texas, Houston, served as Facilitator for the evening session.

S. Curtis remarked, based upon A. Brown's presentation, that it may be profitable for NASA to determine a threshold g force, for missions of lengthy duration, with the intent of supplying a fractional-g environment on a spacecraft in lieu of simulating 1 g. Brown claimed that, since the early 1960's when a trip to Mars was contemplated by USSR, the Soviets have appreciated the possibility of achieving artificial gravity. However, such investigations must be approached empirically (cannot be calculated from models). Brown conjectured that there was not better than a 50% chance that the Martian mission would be run without artificial gravity. P. Callahan added, though, that it was recently determined to be more cost effective to provide an artificial 1 g environment in space than it was to research survivability under fractional g.

J. Kessler's presentation on free swimming organisms induced G. Conrad to inquire if two different species, which formed two different swimming formations, would interfere with each other's swimming pattern. Kessler explained that the size of the pattern is a function of cell concentration, the shape of the containing vessel and the diffusion coefficient of the cells; the pattern itself is modelled by random diffusion and gyrotaxis. With more than one type of organism present, such as with a protozoan contamination, the pattern may not be as regular because of interactions and the presence of cellular products. As an aside, Kessler remarked that a mixing effect could be induced by the turning of a spacecraft and such an effect would interfere with an experiment being conducted in zero g.

In a response to D. Cosgrove, R. Bandurski interpreted the induction of an asymmetric ion distribution in the plant cell wall as actually an alteration of the environment in which some enzymes operate. Cosgrove agreed, and cited how, in his own observations, extension of isolated plant cells walls exhibited all of the characteristics of an enzymatic process (e.g., denaturation at high temperatures, sensitivity to mercury and copper, susceptibility to reducing conditions). Cosgrove tried, so far unsuccessfully, to isolate the wall enzyme(s) and perform a reconstitution experiment for definitive proof. Unfortunately, Cosgrove only had circumstantial evidence of enzymatic action on cell walls. He is aware that a reconstitution experiment, or better characterization of a responsible enzyme, would provide better proof. Bandurski proposed, based upon other experiments, that Cosgrove consider using an antibody against a key component of the cell wall such as the  $\beta$ -1,3,  $\beta$ -1,4 glucan. Cosgrove expressed doubt as to the prevalence of the carbohydrate in dicotyledons and stressed that it would still be indirect evidence for a "wall-loosening" enzyme, but nevertheless the approach could be informative.

J. Kessler posed a question to J. Frangos, pertaining to Frangos' work on the shear force stimulation of osteoblasts. He asked if Frangos' observed effects were not the result of the shear supplying or removing metabolites from the cells. Frangos referred to his work on endothelial cells where he observed an instantaneous (within 8 seconds) increase in intracellular free calcium *in situ*. There was also a linear response of prostacyclin production to shear

rates. If it were a situation of transport or diffusion of nutrients then the response to shearing would be to the  $X^{1/3}$  power not  $X^1$ .

In an attempt to determine if shearing induced a general effect, L. Wiley asked Frangos if he had monitored the response in 3T3 cells. Although he had not, Frangos nevertheless strongly felt that, because phosphatidylinositol (PI) turnover is apparently one of the responsible mechanisms, and all cells are capable of PI turnover, it is an ubiquitous response. In other words, he did not consider it to be mediated by a specific receptor. J. Kessler pursued the issue of space osteoporosis and asked how this mechanism of shear force activation was related to the osteoporotic-like condition resulting from spaceflight. Frangos suspected that the lack of gravitational loading on bone diminishes the effects of pressure gradients which would otherwise drive greater interstitial fluid flow. He further expressed a desire to examine whether the proposed shear stress actually produces a deformation. Kessler suggested detection by EPR (Electron Paramagnetic Resonance).

A. Krikorian wondered if the percentage of active bone cells was determined in animals both on earth and in space. J. Frangos reported that the researchers in bone at the Ames Research Center had determined that there was a reduction in activity of the bone forming cells (osteoblasts) in space. Frangos also explained for Krikorian how, in his shear stress test apparatus, fibronectin was attached to a glass slide by adsorption in order to focus the osteoblasts on the glass slide. At P. Todd's request, Frangos also translated the half-maximal activity measured in osteoblasts ( $200 \text{ sec}^{-1}$ ) to an equivalent of two dynes/cm<sup>2</sup> of shear stress. This half-maximal activity compared to the  $\sim 8 \text{ sec}^{-1}$  measured in endothelial cells when pinocytosis was measured as the response.

Experimental methods were also addressed in the discussions pertaining to the induction of a polarized field in the embryonic study by L. Wiley. J. Kessler asked for clarification as to which is generated first - the electric field or the electric current - and whether they interact with each other. Wiley explained how embryonic polarity is established by outlining her hypothesis for the establishment of a current: the Ion Current Polarization Hypothesis. (She put forth a disclaimer by stating that no markers currently exist for confirmation.)

L. Wiley initiated her explanation by stating that theoretically there is a symmetric distribution of ion pumps and channels around the circumference of blastomeres. As the adhesion of cells occurs, the portions of the plasma membrane that become adherent internally are restricted in their access to extracellular ions. This restriction results in an asymmetric access to ion fluxes across the basolateral and apical membranes. As a consequence of this asymmetric accessibility, *leaks* of various ions occur around the circumference. This situation becomes more pronounced with increased clustering. Eventually, because of the geometric occlusion, there is a net flow of sodium from the outside to the inside of the embryo due to mass effects. Compaction is thought to enhance this process.

With the occurrence of transcellular ion fluxes, associated fields are induced because of the leakage around the outside of the cell. Hence, either by direct electrophoresis of molecules or by electroosmotic drag resulting from the counterions, there is an asymmetric aggregation of molecules and cells. If

these molecules consist of ion channels and ion pumps, then current patterns are established, which is recognized in the blastomeres. Once the the current pattern is established, it remains stable in isolated cells until the cell is ready to divide again. The cell requires no cell junctions to maintain this pattern.

Rather than examine whether cells should be used as biological models in which to study microgravity effects, J. Kessler stated that he would rather consider determining whether the microgravity environment is appropriate in which to study cells. G. Conrad rephrased the question again by asking whether *embryos* are appropriate subjects to study in outer space. He asked if embryos are more hard-wired or more flexible subjects than, e.g., cell lines. L. Wiley illustrated a problem that exists when studying mammalian development by using cell lines. A suitable cell line for use in the study of embryonic development is the embryonic carcinoma stem cell. This cell line came from a highly malignant mouse tumor. If injected into a blastocoel, the carcinoma stem cell colonizes the inner cell mass. When that embryo is transferred to a foster mother and the manipulated blastocyst is allowed to develop into a new-born young, the progeny from the carcinoma stem cell will colonize the embryo. These cells are capable of forming derivatives of all the tissues in the mouse including germ cells.

The carcinoma stem cell line appears to be a good model in which to study differentiation *in vitro*. However, these cells are limited by the fact that they do not form trophoblast, a major component of fertilization which is required to mediate implantation. Hence, embryos are still required for studying mammalian development.

L. Wiley agreed with J. Kessler that it would be better to study embryonic development in species other than mammals, e.g., *C. elegans* or *Xenopus laevis*, since mammalian study is technically difficult. J. Duke suggested that the technical difficulty may have to do with the plasticity of the system itself. She cited her own experiment on embryonic mouse mesenchymal cells in a micromass system. These mouse cells come from cartilage and express clear markers. Because it is known that cartilage is different in animals that are flown in space, the Duke embryonic mouse cartilage system can be used as a test for screening teratogens and to examine cartilage development as well.

In reference to the issue of studying cell models, J. Frangos emphasized that investigators must discriminate between the direct effects on cells (such as altered ATP metabolism) and the indirect effect as a consequence of the effects on the whole organism such as mechanical unloading. Experiments on cells would be looking at direct effects.

D. Cosgrove mentioned that he does not work on single cell systems but is reminded that gravitropism does show up in single cell plants. When he thought of the measurements, such as pH monitoring or  $Ca^{+2}$  readings, which he would like to conduct in the plant cell wall he realized that the optical instruments used to make such measurements (fluorescence for pH and  $Ca^{+2}$ ) would be ideal for generic hardware. As a follow-up to Cosgrove's comment, P. Todd spoke of the movement to set up a Cytometry Work Station in the Space Station and that he and W. Hymer are representatives of that activity. This Conference can be a forum by which investigators send forth a message that there is interest in making quantitative measurements at the microscopic level in microgravity conditions.

J. Kessler described three factors which induce effects in free swimming organisms: gravity, vorticity (or shear), and orienting stimuli, such as illumination. Swimming patterns result which are determined by all three effects and by their relative magnitude. Kessler proposed that it would be interesting to see how these effects interact simply by changing the environment to eliminate one. This possibility was not previously available. In spaceflight gravity can be removed and it is then possible to examine a new range of biological phenomena with single cells and especially with groups of single cells which do not interact *directly* with each other but interact *through the environment* which they create. Subsequently, Kessler listed the basic hardware required: optics, a data acquisition system, including optical recording devices. This flight equipment could be easily developed and form the basic tools to observe the effects of eliminating the gravity vector.

L. Wiley expressed her reservation about drawing conclusions from experiments using separated cells and extrapolating back to *in vivo* effects. She warned that different interpretations of cell experiments would result if one did not initially examine the phenomenon *in situ*. She found this to be true in her own work with field effects.

P. Callahan addressed a question to L. Wiley based upon her presentation on embryonic development. He wondered if the positive side of a blastomere, which was polarized by an external electric field (as opposed to compaction), were to envelop the negative side, would true trophoderm arise and would implantation occur. Wiley responded affirmatively although her initial expectation was that the generated polarity would be conserved. As it appears, the results are random. Embryonic transfers were not performed to deduce whether implantation occurred but a morphologically normal blastocyst was formed, with an outer trophodermal layer, cavitation, polarized solute transport and enclosed cells. Morphologically there is no difference between the blastocyst-like structures that developed from situations where a negative daughter envelops a positive one or vice versa. Morphologically they are identical.

P. Todd asked whether L. Wiley had done any experiments with labelled antibodies developed against the mouse Na-K ATPase to indicate a translocation. Wiley has experimented with the Na-K ATPase as well as the Na-Glucose co-transportase. However, an artifact was generated when the blastomere was removed from the embryo. This problem stemmed from the fact that the Na-K ATPase, which is initially restricted to the basolateral domain, migrates to the apical domain when the the blastomere is extracted out of context. The apical domain is stable and remains conserved when the blastomere is removed from the intact embryo. In general, migration is a typical response of proteins in the basolateral membrane whenever cell contacts are destroyed. Apical membrane transporters, in contrast, remain fixed, even in isolated cells, and will continue to maintain the same rules of transport.

J. Kessler provided the final point for this discussion. He stated that a spherical, internally symmetrical, "isotropic" cell, located in a fluid rotating steadily and slowly within a clinostat, will also rotate, turning upside down once every revolution, as it is swept along with the fluid. The axis of an anisotropic (e.g., bottom-heavy) cell will tilt slightly as it accompanies the fluid in the clinostat. This effect is due to the vorticity. If the fluid rotates

slowly, the cell remains upright. With sufficiently fast rotation, the cell axis then overturns, slowly for the first two quadrants, and quickly for the rest. Similar effects occur whether the cell swims or not, and with cells which are not spherical. Sedimentation must also be accounted for. Kessler warned that if someone has a suspension of cells with an asymmetric center of gravity, and is seeking an explanation of why the clinostat did not work (or gave angular velocity-dependent results), the described situation, proved by the demonstration of gyrotaxis in swimming cells, should come to mind.

## SESSION IV HARDWARE DESIGN CONCEPTS AND OTHER FACTORS WHICH CAN INFLUENCE CELL BIOLOGY IN SPACE

This session addressed the impact of hardware technology and cosmic radiation on cell biology in space. The effect of instrumentation constraints and ground-based simulation technology were also discussed.

Presenters: C. Bruschi, D. Chapman, E. Dunlop, S. Curtis, P. Callahan  
Facilitator: R. Gruener

### 15. Fermentation Growth and Microgravity

Carlo V. Bruschi, Department of Microbiology and Immunology, Biotechnology Program, East Carolina University School of Medicine, Greenville, NC 27858

Development of life self-supporting systems is a milestone in the future of manned space exploration. Among these systems, biofermentation for food and biologicals production is an essential requirement because of the complexity of the reactions necessary to obtain a terminal product. The common yeast *Saccharomyces cerevisiae* is the utmost important microorganism utilized in fermentation biotechnology today. The kinetics of growth under fermentative conditions and the mechanical dynamics of the release of the two terminal products of glycolysis, CO<sub>2</sub> and ethanol, are strongly dependent upon the presence of gravity. The availability of oxygen is a crucial factor in the liquid cultures of cells growing on substrates which are both respirable and fermentable. In addition, the release of CO<sub>2</sub> and ethanol from the cells requires an efficient diffusion into the medium to avoid drastic, localized changes in pH of the medium and catabolite repression phenomena. These processes are susceptible to changes in microenvironmental conditions due to the lack of gravity and the consequent absence of convection and gradient-driven diffusion. The predominance of intra- and intermolecular cohesion and adhesion forces would also represent a biochemical obstacle in reproducing efficient fermentative conditions in space. New approaches to appropriate hardware development for production-scale fermentation, and biotechnological solutions to potentially negative biochemical effects of microgravity are some of the possible solutions to problems related to biofermentation in space. By means of genetic engineering and recombinant DNA technology it is now possible to manipulate the secretion pathway of yeast cells and generate strains with enhanced tolerance to catabolite repression. However, prolonged exposure to cosmic radiation and microgravity can affect the genomic stability and strain homogeneity of long-term chemostatic cultures. The analysis of these problems suggests targeted basic research coordinated with space flight experimentation as the strategy for their solution.

### 16. Ground Based Simulations

David K. Chapman, Gravitational Plant Physiology Laboratory, Philadelphia, PA,

The use of clinostats and centrifuges to explore the hypogravity range between zero and 1 g is described. Different types of clinostat configurations and clinostat-centrifuge combinations are compared. Some examples are selected from literature and current research in gravitational physiology are presented to show plant responses in the simulated hypogravity range

between  $0 < g < 1$ . The data presented indicate the plant responses exhibit the greatest sensitivity to incremental changes in  $g$  in this region. The validation of clinostat simulation is discussed. Examples in which flight data can be compared to clinostat data are presented. The data from 3 different laboratories using 3 different plant species indicate that flight data, but that in all cases were quantitatively different. The need to conduct additional tests in weightlessness that can be used to validate clinostats simulations is emphasized. The use of flight hardware to conduct ground-based simulations is discussed. The advantages and disadvantages of conducting such tests are presented.

#### **17. Plasma Separated Membrane Bioreactor: Results from Model System Studies**

G. R. Petersen\*, P. K. Seshan\*, E.H. Dunlop \*\*, Jet Propulsion Laboratory\*, Pasadena, CA, and Colorado State University\*\*, Department Chemical Engineering, Ft. Collins, CO

The operation and evaluation of a bioreactor designed for high intensity oxygen transfer in a microgravity environment is described. The reactor itself consists of a zero headspace liquid phase separated from the air supply by a long length of silicone rubber tubing through which the oxygen diffuses in and the carbon dioxide diffuses out. Mass transfer studies show that the oxygen is film diffusion-controlled both externally and internally to the tubing and not by diffusion across the tube walls. Methods of upgrading the design to eliminate these resistances are proposed. Cell growth was obtained in the fermenter using *Saccharomyces cerevisiae* showing that this concept is capable of sustaining cell growth in terrestrial simulation.

#### **18. Impact of Radiation on Microgravity Experiments**

Stanley B. Curtis, Lawrence Berkeley Laboratory, Berkeley, CA 94720

Experiments on various organisms (*Tribolium*, *Tradescantia*, *Drosophila*, *Habrobracon*, and *Neurospora*) have shown an interaction between microgravity and radiation on several satellite flights. Results of these experiments have been reviewed by Reynolds and Saunders (1971) and by Shank (1974). Both antagonistic and enhancing effects were noted on various endpoints. The radiation, however, was provided by onboard radioactive sources:  $^{85}\text{Sr}$  onboard Biosatellite II and  $^{32}\text{P}$  on board Gemini III and XI, and the absorbed doses used were considerably above ambient levels: ranging from tens to thousands of rads.

From our present knowledge of the way radiation is deposited in a cell, it is difficult to identify mechanisms whereby the damage caused by radiation can interact with processes affected by microgravity, at least in the case of doses expected on space missions in near earth orbit. Typical dose rates in the space station will be on the order of 0.1 rad/day and an order of magnitude less for many shuttle missions, so that interaction effects with microgravity are not expected to be detectable.

For high-LET (Linear Energy Transfer) radiation as found in shuttle or space station orbits, a very rough calculation shows that one in a million cell nuclei with typical cross section ( $\sim 100 \text{ nm}^2$ ) will be hit per day by a particle with LET greater than 100 keV/mm. Although some recent evidence from the Biorack experiments suggests that there may be a synergistic effect between microgravity and such high-LET particle hits in certain stages of early



embryo development of one organism (H. Bücher, private communication), the infrequency of such hits will prevent them from having a significant effect on microgravity experiments, at least for regions of space inside the sheltering confines of the earth's geomagnetic field.

In summary, although both synergistic and antagonistic effects of radiation and microgravity have been reported at high absorbed doses in space flight and some evidence of interaction between highly ionizing radiation and microgravity has been reported in one stage of embryogenesis in one organism, the radiation levels on Space Station or on lower Space Shuttle flights will be so low that it is expected that the impact of radiation on microgravity experiments will, in general, be undetectable.

### References

Reynolds, O.E. and J. F. Saunders. 1971. The Scientific Conclusions of Biosatellite

II. NASA SP-204, pp. 347-352 .

Shank, B.B. 1974. Results of Radiobiological Experiments on Satellites, in Space Radiation Biology and Related Topics (C. A. Tobias and P. Todd, eds.) Academic Press, Inc., N.Y. pp 313-351.

### **19. Instrumentation: The Additional Factor that Affects Microgravity Bioscience Experiments**

P. Callahan, Space Life Sciences Payloads Office, NASA Ames Research Center, Moffett Field, CA

Proper instrumentation is the key to the success of a spaceflight experiment. Development of proper instrumentation for a microgravity environment, especially under the constraints imposed by a manned vehicle, is a more difficult task than might be imagined. This presentation discusses the definition, design, development and testing of instrumentation, considers the requirements, interfaces and scope of instrumentation, and provides anecdotes gleaned by the Space Life Sciences Payloads Office from simulations and flights.

#### OPEN DISCUSSION - SESSION IV

R. Gruener, Department of Physiology, University of Arizona at Tucson, Facilitated the session which dealt with how hardware design, cosmic radiation and instrumentation design requirements can impact on flight experiments.

B. Taylor questioned C. Bruschi as to what scientific knowledge could be gained from a Bioreactor in space. Bruschi elaborated on the bioreactor production of food stuffs by yeast fermentation in a closed system for applications such as the Space Station. In spite of the problems with palatability, the bioreactor would inexpensively produce a nutritional food enrichment in an environment where space is at a premium. He added, though, that a smaller scale bioreactor exists for the purposes of conducting basic research since a bioreactor is also a potentially good way to grow cells.

R. Gruener saw bioreactors as an example of creativity driven by the associated technical problems. He felt it was encouraging to see this interplay in process and hoped that it could be translated to other situations as well. P. Todd asked E. Dunlop why he chose to internalize the gas exchange as opposed to using an external loop such as used in the horizontal cylinder at Johnson Space Center (JSC). Dunlop could see no reason why an external loop could not be used. The particular model he presented preceded the version which contained a pumped loop. It was only a model, suitable for obtaining preliminary data. He agreed that an external pumped loop was preferable and stated that the new Mark II version incorporated that design. When asked if it was difficult to maintain cells in suspension, Dunlop explained that the hydrodynamic forces and the substantial degree of turbulence present kept the cells in suspension as they circulated past the tubing. J. Kessler pointed out that the persistence of a concentration polarization at the liquid interface would require vigorous stirring of the cells. Dunlop was in full agreement; mass transfer studies have shown the extent of polarization present with the Mark I model. He claimed that the problem would be rectified in the next model by simply having sufficient external circulation past the tubes.

In consideration of the scientific knowledge to be obtained, R. Bandurski wondered if it would be possible to attach a Coulter Counter or some other appropriate device to determine cell shape. It might not be apparent that pronounced problems were occurring with the growth of cells because a very small sampling of the cell population was being monitored. With Dunlop's idea of continuous circulation, Bandurski felt that one could look at the cumulative effects over long periods of time. Dunlop concurred. He has previously demonstrated that micromixing changes the cell size in *Sacchromyces* and is presently postulating that in microgravity the micromixing scale may change. With the combination of micromixing and microgravity, the examination of cells by way of a Coulter Counter was absolutely essential. Bandurski claimed that the bioreactor *was* generic and that, in fact, shear forces on the cells were not really as great as in conventional terrestrial fermenters.

Having followed the development of the JSC bioreactor operation closely, A. Krikorian thought there was opportunity for some imaginative management between industry, NASA, and Principal Investigators in small companies and in universities. In the development of the unique bioreactor system, there has been some hesitancy to reveal information prematurely and some concern for

the patenting of certain features. These are issues which require much work to resolve. Krikorian felt it would be unfortunate if the lack of communication and cooperation among workers in the bioreactor field prevented its progress, and he alluded to the failure of JSC representatives to attend this conference. Krikorian mentioned that there is a tremendous amount of information in the field which must be carefully worked out before the real benefits of the system can be manifested. These benefits should override any reluctance among investigators to tackle these various issues.

L. Wiley noted that there may be a problem with the integrity of the inoculum in view of the radiation impact in microgravity. The extent of mutation should be a primary concern because the mutation rate for microorganisms is higher than for mammalian cells. C. Bruschi was pleased that the issue was addressed. Mutant cells make up a substantial fraction of the population depending upon the mutation rate and the relevance of the mutation to the fermentation process. A biological approach to this problem is to build detection markers, such as a color switch, into the strains used in the fermenter. A cross-section of the population can be analyzed for the extent of mutation. Alternatively, an aliquot of cells could be plated-out but doing so would be difficult to achieve in space. E. Dunlop cited the work of Greg Nelson at Jet Propulsion Laboratory who uses nematodes as a marker for radiation-induced mutagenesis. Dunlop also agreed that mutagenesis was a valuable point and should be examined thoroughly.

With respect to his presentation on the impact of radiation, S. Curtis reported that the revised recommendation for the radiation exposure limit to blood forming organs is 25 rem per 30 days or 50 rem per year. The primary concern is with carcinogenesis, i.e., leukemia. The total amount of radiation that is permitted for an astronaut over an entire career is dependent upon the age and sex of the astronaut. The allowed dose increases as a function of age. And, since female astronauts are susceptible to radiogenic breast cancer, female astronauts are allowed a lower dose of radiation. These recommendations are based upon a comparison of so-called semi-hazardous occupations. Astronauts are considered in a category comparable to occupations with a 3% probability of receiving a fatal accident in a career.

One attendee remarked that P. Callahan had not mentioned the interface problem which exists during an attempt to solve a problem during flight.. The attendee related to the audience a problem on SL-1 which could have been resolved in a few hours had a system by which the orbiter people could talk to the Spacelab been fully developed. Callahan empathized with the speaker having experienced a similar problem with SL-3. As Callahan remarked, with the SL-3 problem it still took 18 hours to implement a solution although they were at least one interface ahead. J. Duke commented that on IML there would be better communication between ground and crew so that problems could be resolved sooner.

J. Duke also added that there were several PI's who would like to see an intense session (2-3 days) devoted to clinostats. The physics of clinostats could be thoroughly discussed for all of the different systems of clinostatting. She also voiced a great need for experimental verification of clinostat data whereby flight data would be compared to observations made on the ground. Such comparisons would help evaluate how good the clinostat was at simulating microgravity. Experimenters, she continued, would also like to be able to

apply more than a 1 g force to distinguish a *gravity* phenomenon from a microgravity phenomenon.

A. Krikorian agreed that a session on clinostats was gravely needed since many investigators use a clinostat in one form or another. In his own work, he finds the clinostat to be very useful. He observed that the qualitative effects were quite similar to the effects recognized in space. Clinostats, he added, are not just for whole organisms but are highly applicable for cells.

## SESSION V INVESTIGATOR SENSITIZATION TO MISSION REQUIREMENTS AND CONSTRAINTS

This session was designed to sensitize investigators to the constraints, opportunities and other experiment design considerations proposed for manned and unmanned space flight missions.

Presenters: R. Ballard, W. Gonzalez, G. Jahns, J. Lashbrook, T. Schnepf  
Facilitator: B. Dalton

### 20. Limitations on Science Due to Mission Constraints

Rodney W. Ballard, NASA-Ames Research Center, Moffett Field, CA

In order to learn about the effects of microgravity on man, and to understand how man evolved in earth's gravity, it is necessary to conduct science experiments in space. The ability to conduct science during a spaceflight, however, is restricted by the following limitations: i) Late/early access - the early loading (Launch minus 18-24 hours) and the late unloading (Recovery plus 2-4 hours) of experiments on board the spacecraft. Delays in launch, for example, could mean up to 54 hours of unattendance. ii) Crew Time - limited availability of a crew member for an individual experiment. A crew member's training may not always be in investigator's discipline. iii) Mission Duration - duration of the flight mission should correspond to the objective of the science experiment. Longer missions may increase crew time but also impose greater power restraints and increased demands on hardware, consumables or specimens. Finally, iv) General Experimental Constraints - the limited opportunities for repeat experiments; the determination of sampling size N by weight and volume restrictions; and the limitations of bioinstrumentation.

### 21. Human Factors Issues in Performing Life Sciences in a 0-G Environment

Wayne Gonzalez, Lockheed Missiles & Space Co., Bioastronautics Division

An overview of the environmental conditions within the Spacelab and the planned Space Station Freedom is presented. How this environment causes specific Human Factors problems and the nature of design solutions are described. The impact of these problems and solutions on the performance of life science activities onboard Spacelab (SL) and Space Station Freedom (SSF) is discussed.

The first area highlighted is contamination. The permanence of SSF in contrast to the two-week mission of SL has significant impacts on crew and specimen protection requirements and, thus, resource utilization. These requirements, in turn impose restrictions on working volumes, scheduling, training, and scope of experimental procedures.

A second area is microgravity. This means that all specimens, materials, and apparatus must be restrained and carefully controlled. Because so much of the scientific activity must occur within restricted enclosures (gloveboxes), the provisions for restraint and control are made more complex.

The third topic is crewmember biomechanics and the problems of movement and task performance in microgravity. In addition to the need to stabilize the body for the performance of tasks, performance of very sensitive tasks such as dissection is difficult. The issue of space sickness and adaptation is considered in this context.

## **22. Future Unmanned Space Flights**

Gary C. Jahns, NASA-Ames Research Center, Moffett Field, CA 94035

This paper will focus on LifeSat, a Reusable Reentry Satellite (RRS) dedicated to life sciences investigations. The Phase A conceptual design study for LifeSat has been completed and the Phase B study will begin this year. As it is currently envisioned, the LifeSat Program will augment the NASA Life Sciences program by providing frequent low cost access to space. There are three currently proposed payload modules planned for development. These include, a Rodent Module, a Plant Module and a General Biology Module. Each payload module will support its payload in a less than  $10^{-5}$  g microgravity environment for up to 60 days. The Rodent Payload Module is being designed to support 12 rodents and the Plant Payload Module to support 12 to 30 individual plant chambers. The General Biology Payload Module will consist of a number of experimental packages integrated into a payload and will provide an excellent facility for the scientific community interested in the effects of microgravity on small organisms, cells, and tissues. To facilitate the handling of biological specimens the satellite is being designed to accommodate late access (L-12 hrs) prior to launch and early access (2 hr) after recovery. The anticipated refurbishment time for the satellite is two months with 2 to 3 missions planned per year.

## **23 Mission Requirements and Constraints on Experiment Hardware**

Joellen Lashbrook, NASA-Ames Research Center, Moffett Field, CA

A summary of the Mission requirements imposed upon experiment hardware to protect the crew, the orbiter and other flight experiments flying on the same mission is presented. Major requirements are grouped and classified according to i) physical constraints, ii) safety considerations, iii) operational limitations and iv) documentation requirements. Hardware design, itself, must undergo a series of formal reviews (Preliminary, Critical and Integrated Payload Design Reviews) in order to meet the requirements for documentation. Any subsequent modification to hardware, and/or operational parameters, impacts upon an extensive list of documents and agreements, such that, the later a modification is requested the lower the chance of approval. In view of all of the prescribed constraints, the "bottom line" for experiment hardware is: scale-down its operation, and design it to be as self-sufficient as possible.

## **24. Telescience**

\*Teri Schnepf and \*\*Kris Vogelsong, \*Lockheed Missiles and Space Co.,  
\*\*Bionetics

Telescience is an operational approach that enables new and better space science by enhancing cooperation between people and hardware from remote locations. This enhanced cooperation is achieved by the ability of a principal investigator to access an experiment from a remote location either to coach the crew through difficult operations, to modify and adjust instructions, or to access data. The main advantage of telescience is that it keeps principal investigators in the loop of the flight experiment, allowing an interaction between them and their experiments. Telescience makes possible adaptable, less rigid experimental protocols and real time monitoring of the experiment by the principal investigator while at his or her own institution.

In order to quantify the benefits of telepresence to space station operations, a life science telepresence testbed has been established at Ames with the following objectives:

- 1) To evaluate crew work quality and crew time savings by providing:
  - a remote coaching environment using teleconference and interacting workstation
  - telerobotic assistance in the Life Science Glovebox
  - voice activation capability
  - remote monitoring capability
- 2) To determine audio, video, and data requirements for life science experiments
- 3) To evaluate conflict resolution for transaction management
- 4) To demonstrate telepresence concepts to life scientists
- 5) To evaluate technologies which enable telepresence

## OPEN DISCUSSION - SESSION V

B. Dalton, Office Chief, Payload Operations Branch, NASA Ames Research Center, acted as Facilitator for this session which focused on factors which influence the design of flight experiments. She initiated the session by mentioning that the management of experiments in space is not as easy as thought back in the early days of Spacelab. While there are multiple constraints to consider in trying to fly an experiment, she stressed that there are positive points as well.

R. Bandurski commented on the apparent contradiction between the radiation exposure permitted for the astronauts on space missions in the 1980's (50 rads) and the amount of radiation (< 2 rads in a 90-day period) allowed in most isotope experiments, even in those involving  $^{32}\text{P}$ . He felt that more experimentation would result if, in fact, restrictions on the levels of radioisotopes were relaxed. S. Curtis stressed that the allowed doses he reported were based *only* upon effects on the blood forming organs and would vary for different tissues. He also mentioned that the permitted dose only accounted for radiation exposure which normally occurred during a spaceflight and not upon radiation from on-board isotopes. R. Ballard mentioned the reluctance of crew members (the human nature factor) to add a particular isotope as a contributing factor to the level of radiation exposure permitted on board spacecrafts. P. Callahan felt that a probable reasoning was that there was already an existing high dose up in space and that radioisotopes were only adding to that level; but he agreed, it was a low allowance. Ballard suggested the use of heavy rather than radioactive isotopes as an alternative.

In reference to the mission constraints on science presented by R. Ballard, B. Dalton commented that a PI did not always fully realize that his/her experiment, for which he had developed an expertise, was being handed over to an intelligent but naive crewmember. It was thus important for the PI to be cognizant of the effect of human factors and of how an experiment can be transformed as a result of this effect.

In response to A. Krikorian's request for information regarding LifeSat 1 g controls, G. Jahns explained the concept of spinning the satellite on its axis to yield forces equivalent of up to 1.5 g. In the general biology module, however, a package would have to be in a specific position to experience a specific g-level. The effect of a specific g force would be better facilitated in a more symmetrical configuration, e.g., for the rat holding facility or the plant module. He also asserted that it would be difficult to accommodate those experiments which preferred to be spun up to 1 g or to be located at the center of the satellite. This capability was being considered for a *particular* mission. Other missions would not involve spinning to accommodate those who did not want variable g effects. Jahns confirmed that an on-board centrifuge posed no problem in view of mass considerations. But, Jahns did add that, for botany considerations, the engineers claimed that a counter-rotating force was not necessary as long as the satellite can be kept at a steady state. Further study, however, would have to be conducted to see if it is necessary to compensate for the acceleration and deceleration phases.

I.G. Jahns informed W. Hymer that the rodent cage had gone through a Phase A conceptual design and, along with the general biology module, is going to be considered in greater detail during the Phase B study. Changes, e.g.,



positioning of waste containment, would be executed especially to accommodate the spinning implementation of the satellite.

G. Jahns also stated that dosimetry is considered to be a critical component of Lifesat missions and that a radiation dosimetry package, although not yet designed, would be placed in a special place on the satellite for each mission. There would also be a three-axis accelerometer on board for the generation of g profiles. Any additional accelerometers would have to be supplied in a separate package by the investigator.

One technical question addressed to T. Schnepf dealt with the glove box (suggested by Schnepf as the "heart" of the the Space Station). She described that the type 3 requirement on the Glove Box indicates that it must remain gas tight. Thus, she confirmed that operation must occur through permanently affixed gloves. Multiple sizes of gloves would be available for this multi-use apparatus and operations would not all be conducted through the large, cumbersome gloves normally associated with Glove Boxes. Adaptations could allow the transfer to surgical gloves for the management of delicate operations; thus, capabilities are being developed to accommodate the multiple types of experiments proposed for glove box execution on Space Station.

In general, the Telescience presentation initiated discussions regarding the feasibility and funding appropriations for such a developing technology. R. Gruener was concerned about the radical change such a state-of-the-art technology would induce in pre-existing hardware. T. Schnepf reflected that the Space Station launch is currently proposed for 1995-6. But, because of budgeting, she declined to give a realistic prediction as to when Space Station would be ready. Similarly, she could not anticipate the kind of impact Space Station and Telescience would have on hardware. W. Gonzales, however, added that because Telescience and scarring for future technologies were two definite plans for Space Station, it would behoove experimenters to design hardware to accommodate these advancements in anticipation of its availability.

T. Schnepf outlined the difference in philosophies between Space Station and previous space missions. Whereas, J. Lashbrook emphasized simplicity, Schnepf reminded the audience that Telescience would better accommodate the long (180+ days) experiments. It would also allow room for error because it is a technology which would allow the PI to monitor and direct modifications. Lashbrook responded by emphasizing that in order to achieve this ideal, it is necessary to take small, but realistic steps.

B. Dalton illustrated NASA's commitment to Telescience by indicating that a large contingency of interested scientists influenced NASA to listen, to funnel money toward Telescience and to develop test bedding. The appeal of Telescience, she espoused, lay in its ability to reduce NASA's paper load, i.e., in its capability of electronically presenting, copying and storing documentation. Dalton also urged experimenters to think about automation and confirm automated operating capabilities on Spacelab flights. Dalton did admit that crew members were generally reluctant to have experiments automatically conducted in their space craft without their full knowledge of *what* and *when* something was occurring, e.g. reservations about automated use of hazardous material such as glutaraldehyde.

It was suggested that NASA mission managers would be reluctant to relinquish *their* control of space missions in the favor of a management center. J. Lashbrook suggested that mission managers, instead, wanted to keep their control of missions in order to prevent the creation of a many-headed monster. As a NASA engineer, Lashbrook concurred that Telescience was a concept which should be developed. But, she doubted if she would see it executed in the near future.

P. Seshan wondered if there was a plan for a concept of *Teleoperations* where the PI on earth had the experience of running the experiment himself, i.e., he would have a set-up on earth where he could perform the experiment and by doing so would practically be performing it himself in space. T. Schnepf recognized how his concept fit into the general concept of Telescience but said that it was simply a notion that is under discussion. She doubted if a crew member would allow such spontaneous activity to occur. There were also many issues to deal with: would the crew be up-dated on conducted procedures, how and when could the crew interfere. W. Gonzales interjected that one important aspect of Telescience to remember was that it reduced crew training which the space program and the astronaut corps consider to be too expensive even currently.

B. Dalton reminded the panel of presenters that one of the goals of the Conference was to move toward generic hardware. She queried the panel as to how far generics should go. J. Lashbrook, after discussion with other attendees, vocalized a desire to see hardware advertised more. She favored a separate conference, or an attached day, devoted to the discussion of just hardware. More advertisement, furthermore, would allow experimenters to be creative and recognized whether they could apply certain hardware for their experiments.

J. Kessler thought that the notion of Telescience could be merged with the call for hardware simplicity by the automation of simple devices. Such automation would relax some of the more tedious duties of the crew members without going into the full development of the Telescience activity. Both W. Gonzales and P. Callahan cited problems with out-dated equipment which could not even accommodate the modifications required for automation. J. Lashbrook liked the challenge and suggested that perhaps crew members could be used to initiate operation ("flip the power switch"). When Kessler suggested that Crew members could be trouble-shooters, Lashbrook recognized that that capability would require crew training.

A. Krikorian was concerned with whether an experimenter would have to verify his design concept and hardware on a Spacelab or Space Shuttle mission before it was used on Space Station. He mentioned that the NASA Science Working Groups were concerned about this because the experiment environments were entirely different between the Spacelab and Space Station. With this disparity in spacecraft, a new generation of hardware would have to usurp the existing hardware. He felt that that the manner in which this hardware technology was transferred should be given much thought. Even though G. Jahns suggested that certain high risk components would have to undergo, at the very least, a subsystem test. Krikorian insisted that hardware would undergo redesign in order to operate on the Space Station. J. Kessler suggested that instead of designing and building hardware which can all be reused, it may be cost effective to build a large number of expendable items. It

would not be the re-use of the same thing but the re-use of the same design since considerable expense comes in the *process* of development, i.e., the people, the time. R. Ballard vouched that the same technology could be re-used as long as it was re-evaluated to eliminate any problems found in the initial design.

R. Ballard continued, however, by saying that the whole international space community is going away from the single PI use of equipment to more general, multi-purpose equipment. Because Ballard envisioned generic equipment possibly not suiting anybody, he encouraged workshops and advisory groups to cooperate on a reasonable design of equipment for multiple uses which can meet the requirements of good science.

Along this line of generic hardware development, R. Mains related a suggestion to the conference audience that originated from the Advanced Biomedical Sensors project at Ames Research Center. In a recently conducted symposium which discussed biomedical sensor development for the year 2000, considerable discussion revolved around the notion of forming an instrumentation working group with representatives coming from science and from bioengineering. He articulated that small groups (8-10) of compatible scientists and engineers could propose straw-man concepts for both generic experiments and hardware. These concepts would get sent back to Science Working Groups and to larger groups, such as those attending this Conference. In essence, people would be allowed to react to proposals which were detailed enough to generate critiques and initiate possible modifications. Because of the apparent compromise in science which could result from adapting to generic instrumentation, Mains asserted that such an instrumentation group would be essential for testing the feasibility of generic hardware use in cell research.

In addressing the generic hardware issue, P. Todd said that he considers analytical equipment as most widely desired and appropriate for this category. As far as hardware for specific experiments is concerned, Todd agreed that multi-use equipment may not meet everyone's needs. However, he is reminded of how very different hypotheses can be tested using similar experimental methods and involving only minor modifications. Todd would like to see a trend in which experimental hardware is designed for specific experiments but generic instrumentation was being designed for the analytical procedures required by everyone.

On the issue raised by D. Chapman regarding the operation of hardware on the ground before flight, P. Todd warned that the ground testing of mock-up hardware not destined for flight is not the same as testing an operational model with a spare, flight model in storage. Todd mentioned that a piece of flight hardware should be almost "worn-out" by the time it is ready to be installed for space operation. Ground-based testing can give the investigator the opportunity to monitor and evaluate the performance of his/her experiment. If the experiment cannot run for more than a few hours then the PI may have to rethink his experimental design.

R. Bandurski espoused the attributes of the NMR as the single most applicable piece of apparatus for biological monitoring. He also expressed dismay at the suggestion that the existing, limited budget would not allow an NMR but that substantial funds appeared to be available for Telescience or the Hubble space

telescope. It was unfortunate that the most rapid piece of developing biomedical instrumentation was not available for space. R. Ballard disagreed saying that all that is needed is a definite recommendation for a piece of instrumentation so a program can be developed to find funding to obtain it. Ballard cited the work being done for flow cytometry and for a scanning electron microscope. He also alerted the audience on the Office of Aeronautics and Space Technology which is a component of NASA which specifically looks for technology to develop. Along the same vein, B. Dalton mentioned that just as it takes an investigator to recognize an instrumental need, a PI can also alert NASA to a piece of hardware in his possession which is simple and applicable to a space experiment.

## **SESSION VI EXPERIMENTAL AND COMMERCIAL APPLICATIONS IN MICROGRAVITY**

This session focused on the commercial opportunities available and hardware required for space research as presented from several viewpoints.

Presenters: L. Milov, P. Seshan, M. Deuser, W. Hymer, M. Luttges, E. Dunlop, S. Smith, K. Soliman

Facilitator: L. Milov

### **25. NASA Commercial Space Life Sciences**

L. Milov, Office of External Relations, NASA Ames Research Center

With the growing emphasis on space life sciences research, it is appropriate that we begin to explore potential commercial applications. The Space Shuttle and ultimately the Space Station provide an environment in which to explore the unique effects of microgravity. In order to facilitate this utilization, NASA Headquarters has instituted a number of programs to encourage industrial involvement. Several of these will be discussed, the primary one of which is the Center for the Commercial Development of Space Program.

### **26. Design Considerations for Space Bioreactors**

P.K. Seshan, Jet Propulsion Laboratory, Pasadena, CA

The importance of the bioreactor is based on its potential to provide an alternative food source, pharmaceuticals, and biologicals (vaccines, hormones), and its capacity to support basic science research. Following a quick review of major types of bioreactors, both conceived for and tested under conditions of microgravity, this paper focusses on the type of data required to design bioreactors for use in low or no gravity space. Factors which must be considered in bioreactor designs are the natural convections and the interfacial turbulence, the latter resulting in viscosity and concentration gradients. The rate of cell mutation must also be evaluated. Obtaining preliminary data in space will allow optimization of bioreactor design, i.e., an increase in productivity with a minimum of cell damage. A representative set of flight experiments, as the means to obtaining such data, are outlined.

### **27. Meeting the Investigator's Hardware Requirements**

Mark Deuser and John C. Vellinger, Space Hardware Optimization Technology Company, Floyd Knobs, Indiana.

The flight hardware design for an investigator's microgravity experiment can have a very positive effect on the outcome of the experiment. Unfortunately, it can also have a detrimental effect if it forces a major change in the experimental methods to accommodate deficiencies in the hardware. A flight hardware developer must provide hardware which meets rigid specifications for flight hardware certification, at competitive costs, and on schedule. The developer must maintain good communication with the investigator throughout the development process to ensure that science requirements are met and chances are maximized for obtaining interpretable results from the flight experiment. We will demonstrate an egg incubator system developed by

our company to fit a Shuttle mid-deck locker for an experiment which is part of the Shuttle Student Involvement Program. The system has proven to be a simple, effective solution to providing basic life support and monitoring for avian development studies, has passed flight certification, and is scheduled for launch in the very near future.

## **28. Center for Cell Research**

Wesley Hymer, Pennsylvania State University, University Park, PA

Abstract unavailable for the impromptu presentation by W. Hymer.

## **29. Countermeasures to Microgravity**

Marvin W. Luttgies, Aerospace Engineering Sciences and Bioserve Space Technologies, University of Colorado, Boulder, CO

Biological systems ranging from the most simple to the most complex generally survive exposure to microgravity. Changes in many characteristics of biological systems are well documented as a consequence of space flight. Neither the significance nor the causal agents of such changes are well understood. Nevertheless, we can begin to question whether or not these changes can be avoided, reduced or reversed while continued exposure to microgravity ensues. Attempts to devise countermeasures to microgravity may have direct pragmatic consequences for crew protection and may provide additional insights into the nature of microgravity influences on biological systems.

Some of the most well documented changes occur in humans who have experienced space flight. Changes appear to be transient. Space adaptation syndrome occurs relatively briefly whereas bone deterioration may require months of postflight time for restoration. It seems critical to recognize that these changes and others may derive from rather passive, active or even reactive changes in the biological systems that are hosts to them. For example, hydrostatic fluid redistributions may be quite passive occurrences that are realized through extensive fluid channels (vascular, lymphatic etc.) Changes occur in cell metabolism because of fluid, nutrient and gas redistributions. Equally important are the misconstrued messages likely to be carried by fluid redistributions. These reactive events can trigger, for example, loss of fluids and electrolytes through altered kidney function. Each of these considerations must be evaluated in regard to the biological site affected: intracellular, membrane or extracellular foci.

Countermeasures to the vast range of biological changes and sites are difficult to envision. The most obvious countermeasure is the restoration of gravity-like influences. Some options are discussed. Our recent work has focussed on the use of magnetic fields. Pulsed electromagnetic fields (PEMF) have been shown to alleviate bone deterioration produced in rodents exposed to tail suspension. Methods of PEMF exposure are consistent with human use in space. Related methods may provide muscular and neural benefits. PEMF exposure is unlikely to be a panacea for all microgravity effects. There exists a variety of alternative procedures. From which we can learn more about microgravity effects on biological systems including humans.

### 30. Mass Bioreactor

Eric Dunlop, Colorado State University, Department of Chemical Engineering, Ft. Collins, CO

See Abstract #17 for a continuation of an earlier presentation on bioreactors.

### 31. Bone Mineral Measurements Using Dual-Photon Absorptiometry

Steven W. Smith, Lunar Radiation, Madison, WI

Measurements taken before and after extended manned space flights have shown that weightlessness greatly accelerates bone demineralization. At the measured loss rates of 1 to 3% per month, bone fractures could be expected in as little as 1 to 2 years. Additional studies are required to better understand the fundamental processes of bone demineralization. X-ray Dual-Photon Absorptiometry systems developed during the last year have significantly improved the ability to measure bone mineral. The high precision and low radiation dose of this technique allows detection of bone mineral changes of less than 1%. Measurements can be taken directly at the anatomic sites of interest, namely the femoral neck and the lumbar spine. This will allow the required bone mineral studies to be completed in a shorter time and with greater confidence.

### 32. Clinical Use of Metaplastic Neurological Differentiation of Chromaffin Cells under Microgravity

K.F.A. Soliman and J.W. Brown, College of Pharmacy, Florida A & M University, Tallahassee, FL 32307 and Department of Medicine, University of Miami School of Medicine, Miami, FL 32101

The neurological differentiation of neural-crest derived adrenal chromaffin tissue has been demonstrated *in vitro*. The metaplastic transition of epinephrine producing endocrine tissue into cholinergic neurological structures appears to be under control of biochemical and tactile stimuli. There is presently no information relating the extent of gravitational influence on these interactions or transitions. A detailed investigation of such effects and alterations in drug and hormone-induced cellular influences on cellular changes under microgravity environment in NASA Shuttle Flights may reveal important information concerning gravitational influences on cellular differentiation and the expression of biochemical cellular functions. Bovine adrenal chromaffin will be isolated and cultured in *in vitro* approximately 2-3 weeks before shuttle lift-off. Prior to launch (ca. 12-18 hrs.) cells will be given new medium and treated with control, dexamethasone (10<sup>-5</sup> M) or GABA for determination of basal and drug-induced post-flight cellular alterations in catecholamines (dopamine, norepinephrine, epinephrine), a key cholinergic neuronal enzyme (e.g., choline acetyltransferase) cell viability and growth (by laser flow cytometry) and morphology parameters (neurite project and synapse formation). Cellular catecholamines, choline acetyltransferase (neurological marker) will be analyzed for comparison with normal gravity controls receiving otherwise similar treatment. The metaplastic differentiated chromaffin cells will be examined and tested as dopaminergic neurons. If the cell differentiation is dopaminergic, similar cells from humans could be incubated at microgravity and then transplanted into patients with Parkinson's disease.

## OPEN DISCUSSION - SESSION VI

L. Miloy served as Facilitator for the session which presented current commercial applications in space research. He is the Chief of the Office of External Relations at NASA Ames Research Center.

R. Hammerstedt opened the discussions by asking the bioreactor experts if there are new techniques being developed to remove toxic materials. The conventional procedure, of which Hammerstedt was aware, uses high speed dialysis for waste removal but such a system does not appear practical for a water-limited environment such as the Space Station. He was also interested in the capability of adding back nutritional factors since nutrients in a slurry are not consumed at equal rates. E. Dunlop claimed that, for food production, it would not be necessary to remove secondary metabolites although they *do* exist. The aim of the design is for continuous experiments and not just for batch production. Under situations of longer use, there is lactic acid accumulation as a secondary metabolite but its quantity should be  $\ll 1\%$  of the total biomass. In terms of nutrition, Dunlop insisted that at this moment it is not a major concern. Dunlop suggested that membranes could be inserted in the bioreactor for secondary metabolite removal. P. Seshan added that the mammalian cell bioreactor at JSC contains a whole system of filters to screen out toxic substances and that there are plans to adjoin the reactor from the Jet Propulsion Laboratory to the bioreactor system at JSC. This "solution by dilution," however, does not address the concept of selective toxic waste removal from a circulating system mentioned by Hammerstedt.

When R. Hammerstedt inquired about the bioreactor application to mammalian cells, Dunlop confirmed that, in terms of oxygen transfer,, mammalian cells are easier to grow in a bioreactor. The oxygenation levels in mammalian cell culture systems are comparatively easy to obtain. At high cell density mammalian cell growth becomes more difficult because the transfer of oxygen becomes more important. Bioreactor engineers wish to drive up the intensity of  $O_2$  transfer to achieve a maximum  $kg\ O_2\ transferred/m^3\ reaction\ space/hr$  and a maximum  $kg\ O_2\ transferred/kwh$ .

When asked for the efficiency and the amount of  $kg\ O_2$  transferred during *normal* operation of a similar size bioreactor on the ground, E. Dunlop replied that a typical conventional lab-based fermenter (5-20 liter) would operate at  $\approx 1-2\ kg\ O_2/m^3/hr$ . A large scale fermenter would occasionally attain  $10\ kg\ O_2/m^3/hr$ . The power efficiency was comparable to that of a very efficient fermenter. The power measurements were not obtained empirically but calculated from a very good mock-up. There is no system to measure power on the present model but there are plans to incorporate a power meter in the next design.

A. Krikorian added that it is possible to catabolize metabolites and secondary products down through certain pathways by altering the relative amounts of substrates in the metabolic network. In this regard, one could study, on earth, the controlling aspects of metabolism by manipulating metabolites within the bioreactor.

J. Frangos noted that a difference seen between the bioreactor models presented at this Conference and the bioreactor at JSC was the extent of



mixing. E. Dunlop concurred also saying that he wants to increase the amount of mixing and agitation to minimize the boundary layer effect and thereby increase the O<sub>2</sub> transfer. However, maximizing agitation is a prerequisite for operating the newer generation of bioreactors. For growing mammalian cells the oxygenation level in the current configuration is already sufficient.

A. Krikorian believes that a smaller version of the bioreactor used as a research tool would facilitate the more tedious laboratory operations. He also added that the high viscosity manifested in plant cell cultures could be controlled to enable application to a bioreactor. The problems he does foresee, however, are with the need to harvest and extract materials, i.e., products are not easily accessed from the media. And, as it is currently designed, the bioreactor, also, cannot accommodate periodic pulse-labelling or centrifugation for media replacement. But Krikorian suggested that this aspect could be automated as well.

J. Kessler proposed to the bioreactor engineers the idea of reversing the bioreactor system such that the oxygen was in the vessel and the cells circulated in the tubes. Kessler asserted that, with this configuration, shear and stirring could be eliminated from the flask. E. Dunlop thought that the bioreactor could theoretically run with that concept. It was more *convenient*, however, to run a bioreactor with the tubing occupying 5-10% of the reactor flask volume. But, theoretically, as long as you move the fluid relative to the tubes it did not matter where it was located. P. Todd agreed, cells were not usually *pumped* through, but they could be either internally or externally located. He also added that the bioreactor at JSC actually rotated a horizontal reaction vessel. On a closing note, P. Seshan mentioned that such a configuration may not yield as efficient O<sub>2</sub> transfer because of cell clumping in small tubes. It would also be harder to control the rate of cell flow.

C. Winget was interested in how a small company such as SHOT (Space Hardware Optimization Technology) first contacted its PI's for the development of flight hardware. As M. Deuser explained, the chicken embryo experiment, for which he designed and developed hardware, was an experiment proposed by J. Vellinger for the Shuttle Student Involvement Program. It was during this initial experiment development that M. Deuser and the PI, J. Vellinger, recognized the engineering opportunities in space hardware development. They then formed a partnership and SHOT came into existence. Both engineers learned much regarding the extensive testing and evaluation process by which hardware progresses from paper to spacecraft. Presently, the Japanese are consulting with SHOT over the design of a suspension apparatus to allow quail eggs to withstand launch vibrations. Such an experiment is targeted for a future Space Shuttle mission.

S. Upton queried whether serum levels of calcitonin or parathyroid hormone (PTH) have been measured in astronauts or experimental animals flown in space. Baseline, postflight and possibly inflight serum measurements would elucidate mechanisms behind the bone defects which occur in space. He was wondering whether pharmaceuticals could be used to control such skeletal problems. P. Callahan reported that rats flown on SL-3 had preflight and postflight measurements of osteocalcin and PTH. Postflight measurements, unfortunately, did not occur until 2 1/2 hours after landing by which time changes in systemic hormones had occurred. K. Souza confirmed that blood analyses were also conducted at JSC on the astronauts but did not recall what

those particular measurements were. He can refer people who are interested in these data to informed persons at ARC or JSC.

A. Krikorian was curious about K. Soliman's work with totipotent or pluripotent cells and asked if he had any idea if chromaffin cells were sensitive to g levels. Soliman admitted that, even though he knew his cells would tolerate centrifugation, he had not conducted studies on gravitational effects and could not predict a response to hypergravity conditions. Judging from such a "clean cut system," Krikorian had no doubt that Soliman could determine if such an effect exists. G. Conrad suggested, furthermore, that Soliman differentiate between any sub-populations present in his culture of chromaffin cells because Soliman may not be dealing with pluripotent cells but with a mixture of cells where subpopulations are selected by different conditions, e.g., dexamethasone treatment. Conrad claimed that such effects occur in embryonic and possibly adult cells.

## SESSION VII FACILITATOR SUMMARIES AND ATTENDEE INPUT FOR FUTURE EXPERIMENTS IN SPACE

After summarizing the presentations made in his/her session, each Facilitator reviewed the recommendations and summary comments as they generally related to the two major topics of the Cells in Space II Conference: 1) Cells as biological models and 2) Experimental Flight Hardware.

### SESSION I: DOES MICROGRAVITY AFFECT CELL STRUCTURE AND/OR CELL FUNCTION?

FACILITATOR: A. COGOLI

To address the question of whether cells are sensitive to gravity, a critical review of past experiments flown in space is necessary, especially with separate evaluations of the following experimental areas: methodology, technology, controls and results. The importance of reproducibility of flown cell experiments was also emphasized. There have been cell experiments which have had the opportunity for repeated flights (paramecium, lymphocytes, E. coli and antibiotics), and as a result, have confirmed that the microgravity environment has an effect on cell structure and/or function. Results were presented in this session by W. Hymer, G. Sonnenfeld and A. Krikorian which were also suggestive of microgravity effects.

However, to address the question of whether the cell is an appropriate biological model in which to study the effects of microgravity, there is a need to discriminate effects under specific instances:

- Adhering vs. Non-adhering cells, i.e., are resuspended cells more affected by microgravity than the attachment-dependent cells?
- Differentiated vs. Non-differentiated, i.e., are cells in the process of differentiating more sensitive to microgravity than non-differentiating cells?
- in vivo vs. in vitro effect, i.e., are the effects that occur at the cellular level in whole organisms comparable to those observed in cells in culture?

It was asserted that a gravity receptor, similar to that of plants, is unlikely in animal cells. The effects observed are not the result of a gravity sensing mechanism but rather a reaction to a change of the cell's environment, e.g., temperature, concentration, pressure etc. Gravity sensing is probably due to a series of small effects on several biological mechanisms and on events which are part of cellular processes, such as differentiation, mitosis, biosynthesis of cell products etc. The problem can be approached by using concepts such as far-from-equilibrium thermodynamics and bifurcation systems (Prigogine and Kondepudi). However, the observed effects on cellular processes such as chemotaxis, motility, cell movements and cell contacts can also have resulted from direct effects on the cytoskeleton and membranes. In fact, several open questions still remain concerning the space experiments conducted on lymphocytes, e.g., regarding early and late effects of Concanvalin A on

proliferation, or Interleukin-2 receptor expression. Thus, there is an effect of microgravity on cells, but the mechanism of this effect requires further investigation.

Concerning hardware, the emphasis should be primarily on basic research. It is premature to address the issue of commercial applications. It was suggested, however, that a common research facility, such as the Biorack community or LifeSat, be developed, or improved upon, to provide an environment conducive to the investigation of microgravity effects. These opportunities help to create a scientific community for collaboration and harmonious research pursuits. In addition, the use of sounding rockets, stratospheric balloons and Lifesat for experiments should be encouraged.

Moreover, it is necessary to examine microgravity effects in more than one type of cell, and the following cell types were recommended as candidates for inflight cell study: lymphocytes, bone cells, erythropoietic cells, plant cells, blastomeres, pituitary cells, and bacteria. In addition, the following parameters were suggested for studying cellular microgravity effects: proliferation, ultrastructure, cell-cell contact, motility, chemotaxis, and biosynthesis of important cellular products.

Finally, the need for extended ground-based investigations, using centrifuges and clinostats, is underscored in order to reach a common understanding of effects. The on-board centrifuge, as a control, is considered an obvious requirement.

## **SESSION II: BIOPHYSICAL PHENOMENA AND THE GRAVITY RESPONSE**

**FACILITATOR: P. X. CALLAHAN**

All of the presentations in this session underscored the fact that there are several candidate physical phenomena which depend upon gravity. In fact, many areas are available for investigation. Examples include work, hydrostatic pressure, flocculation, sedimentation, diffusion, thermal gradients, buoyancy, inertial acceleration, depolarization and voltage gates. There was also a consensus that there exists a number of other, "weak" factors, which, through amplification, could result in a reactivity of the cell to gravity.

The papers in this session proposed pathway models and presented transduction mechanisms by which a cell or organ could manifest its reactivity to gravity. Such presentations included a discussion on bacterial chemotaxis by B. Taylor, on physical phenomena and their relation to the microgravity response by P. Todd, electrophoresis by D. Clifford, techniques of microelectrophysiology by T. Björkman and voltage-gated channels by R. Bandurski. The abundance of potential models re-emphasizes the requirement for ground-based investigations before such models can be proposed for flight investigation. Existing results further substantiate this conclusion.

The issue of generic hardware to support these investigations was discussed. No generic hardware was discussed aside from hardware for inflight manipulation, such as scissors, transfer apparatuses, wet chemistry systems microscopes. This session, instead, generalized its hardware needs in terms of desired analytical techniques. The most universal desire was for an ability to observe, in real-time, processes which would occur while in orbit. The flight hardware suggested which would enable such real-time analyses

include instruments for cell manipulation, microscopy and flow and image cytometry. In particular, there was strong support for an inflight NMR/MRI (Nuclear Magnetic Resonance or Magnetic Resonance Imaging) which would allow observation of processes as they occurred in microgravity. Magnetic imaging would yield unique information easily and in a short period of time. As an alternative approach, additional flight hardware should be capable of sequenced "frozen-time" fixation for sample/specimen analysis to be performed postflight on Earth.

### **SESSION III: GRAVITY UNLOADING - UNDERSTANDING THE INPUT AND OUTPUT MECHANISMS OF THE ORGANISM RESPONSIBLE FOR THE TRANSFORMATION OF INERTIAL ACCELERATION INTO A RESPONSE**

FACILITATOR: J. DUKE

A primary question addressed by the Conference was whether it is worthwhile to fly cells in space - the answer is Yes. Just as the study of cells may be appropriate for gravitational biology, it may also be appropriate for microgravity research. For example, in vitro systems may be required for studies of mammalian development to obviate maternal effects (NASA Developmental Workshop, NASA TM 86756). The qualification given by the participants in this session emphasizes that cell experiments flown in space should study the appropriate cells, using the appropriate hardware and asking the appropriate research question. This qualification to cell experiments can be insured by peer review, especially when reviewers include individuals familiar with gravitational biology.

To ask whether the cell is an appropriate biological model to study in space is indirectly asking if gravity affects the cell and whether this effect is a direct one. Based upon results of cell experiments flown in space, the answer is a resounding Yes. However, whether the effect is direct or not is not as easily answered because of the possibility of gravity sensing by specific sensors and gravity sensing owing to inadvertent effects on cell metabolism. For instance, it is proposed that the unloading of bone will change the electrical charge on the bone and thereby induce a change in bone cell activity. Is that a direct or an indirect effect? Does a direct effect refer only to the presence of a statolith? If so, there are still many steps - most yet undefined - between displacement of a statolith and the response of an organism. The terms g-sensor and g-sensitivity have also caused confusion. To ask whether a cell is "sensitive to g changes, either fortuitous or essential" is quite a different question from "does this cell possess a g-sensor?" (essential response).

Regarding the use of generic flight hardware, the following recommendations were made in this session: microscopes and cameras should be readily available and as close to state-of-the art as possible. If necessary, NASA regulations should be changed to accommodate this need. The flight of both 1 g and variable g centrifuges was stressed as well as provisions for the inflight use of fluorescent tracers. There is also a need for fluid-handling systems for automatic feeding and fixation devices for cell cultures. The Europeans have had a long-standing interest in cells in space and have excellent hardware, much of which is automated, for cell culture. Such hardware can be flown on sounding rocket flights or on the Soviet Cosmos

satellites. The U.S. should not wait until LifeSat is ready to begin development of automated hardware.

The limitations to the ways cells can be profitably used in space are not exclusively scientific, or even engineering. The limitation is in flight opportunity. The following suggestions are offered to maximize the scientific return from each experiment flown:

- There must be increased communication between engineers and the PIs. The PIs must be able to tell the engineers what is needed, and the engineers must listen to the PIs and the PIs to the engineers since not all PI desires can be accommodated.
- There needs to be increased distribution of information on NASA cell culture hardware, and a plan to make limited amounts of prototype hardware available to interested parties. ESA (European Space Agency) has recently sponsored the preparation of a publication ("Biology in Microgravity: A Guide for Experimenters") which contains such information regarding ESA-sponsored experiments.
- There needs to be an increase in opportunities for communication between the fluid physicists, materials scientists and biologists. The first two groups can aid in such matters as fluid handling in space, so that biologists do not reinvent the wheel. Questions of diffusion, gas exchange, etc., could also be addressed by members of these other groups.
- Ground-based models need to be validated. This includes centrifuges, clinostats and unloading methods. NASA now categorically states that the clinostat (whatever "the clinostat" is) is a microgravity simulator, although no evidence exists that this is the case, especially at the cellular level. NASA also states that excess g studies cannot be predictive of microgravity results. Both of these are statements of beliefs, not of scientific results.
- Experiments must be repeated (reflown) in order to validate results. Also, standard operating procedures for 1 g must be used in space as much as possible. These two recommendations are needed in order for NASA to gain credibility with the general scientific community.

#### **SESSION IV: HARDWARE DESIGN CONCEPTS AND OTHER FACTORS WHICH CAN INFLUENCE CELL BIOLOGY IN SPACE**

FACILITATOR: R. GRUENER

A. Bioreactors. As conveyed in the presentations of C. Bruschi and E. Dunlop, Bioreactor design has already achieved two major objectives: first, to examine cell processes in mass cultures, and second, to provide a means for food production. Earth-bound systems, however, require certain modifications to achieve these goals. For example, the absence of gravity, during flight, requires that special attention be paid to the control of pH, oxygen delivery, carbon dioxide removal and maintenance of optimal temperatures. Several solutions to these problems have been discussed and are presented in the papers summarized here. It is clear that bioreactors will form an important

element in the provision of food stuffs, during prolonged flights, and for the investigation of the effects of microgravity on cellular processes, including cell-cell interactions, mutation rates in space-flown cells growing in mass cultures and product separation technologies. Expertise from biochemical engineering, fluid mechanisms and cell biology will be required to converge on the design of bioreactors capable of generating cell products for food consumption and for the examination of cellular processes. Because bioreactors are likely to become an essential element in the life support system, for prolonged space flights, a high priority should be given to the development of scaled-down versions, such as are understudied at the Johnson Space Center, to be tested on forthcoming flights. Development of such systems is very likely to have significant watershed effects in biotechnology and in cost-effective food production.

B. Clinostats. As discussed in D. Chapman's presentation, the clinostat is an essential tool in cell biology research as it pertains to microgravity. The device provides, in principle, an environment in which the gravitational vector is made symmetrical from the cell's perspective. Thus, cell behavior in a clinostat is the only tool available for earth-bound experiments from which cell behavior in microgravity may be extrapolated. At present, there appear to be few, if any, unifying principles for cell behavior as a consequence of exposure to a symmetric gravity stimulus. It is therefore essential that clinostat experiments be carried out in parallel with flight experiments. This is the only way in which verification of the extrapolations can be achieved. It is reasonable to expect that from such parallel experiments, more precise extrapolations will culminate in the definition of behavioral principles which will define how cells develop, grow and function in the microgravity environment of space. Vector-free gravity experiments in clinostats, with verification from experiments flown in parallel, are needed to understand essential processes such as cell-cell interactions, cell product formation and secretion, and cell metabolism.

C. Flight Hardware for Cell Experiments. Because of crew safety and the constraints imposed on flight hardware, it is important to investigate cell processes in space by additional experiments carried out on unmanned flights where hardware design specifications may be less stringent and therefore less costly. By utilization of streamlining in the production of "generic" hardware, it may be possible to optimize design, processing and manufacture of such hardware. Furthermore, the presentation by S. Curtis made us consider the impact of radiation on microgravity experiments. While the probability of radiation damage to single cells is quite low, the ability to distinguish radiation effects from microgravity effects must be provided. Delineation could be accomplished by conventional metering devices, and the reduction of radiation by appropriate shielding. In addition, the insight offered by P. Callahan into complexity of specifications for flight hardware led to the recommendation of the implementation of a "buddy" system, in which investigators on new flight experiments rely on "veterans," to optimize considerably the execution of flown experiments. Finally, an essential element contributing to the viability of research on the gravitational effects on flown cells is the establishment of stable funding for both long-wait and short-wait experiments.

In summary, conferees concluded, from a considerable volume of data, that substrate-attached cells, as well as cells in suspension, are extremely useful in elucidating fundamental processes which might be affected by exposure to microgravity. This is especially true for certain cell types (e.g., secretary,

neuronal) and specifically during certain crucial periods of development. Of additional global significance is the likelihood that cell experiments carried out in microgravity, and in parallel in vector-free gravity conditions, are likely to shed new light on the adaptation of cells (and therefore organisms) to the prevailing 1 g environment of Earth.

## SESSION V: INVESTIGATOR SENSITIZATION TO MISSION REQUIREMENTS AND CONSTRAINTS

FACILITATOR: B. P. DALTON

The session on generic hardware addressed not only generic hardware currently in existence and its application to future microgravity flights, but also factors which must be considered in the design of hardware for microgravity flights.

Dr. Rod Ballard's presentation on "Limitations on Science Due to Mission Constraints" addressed the effects of late/early access currently required for Transportation System (STS) flights. The experimenter is forced to consider the "real" experiment initiation and completion time, i.e., can the experiment to be completed within the microgravity environment avoid the potential readaptive forces experienced in Earth's one-gravity environment during the two, or more, hour-delay in recovering an experimental system. Additionally, electronically-driven data inspection is limited during the launch and reentry periods. If these periods are suspected to have grave impacts on the biological system, a suitable monitoring capability must be designed into the hardware. Experiments requiring extensive crew manipulations may suffer if other flight activities take priority. Added to the above constraints, the issues of safety in design of hardware lead to the conclusion that providing "generic" hardware in today's STS atmosphere is constrained. The audience was advised to remember these constraints in terms of their wished-for scientific return and to utilize and evaluate hardware currently available, i.e., Japanese, European Space Agency, U.S. Life Sciences Life Sciences Laboratory Equipment (LSLE), prior to proceeding into additional design efforts.

Dr. Gary Jahns gave an overview of Lifesat, a NASA-proposed generic microgravity facility, which is intended to be operational in 1993. This unmanned biology facility is proposed as an alternative to the oversubscribed and limited STS flights. As currently planned, the facility could be configured to accommodate 12 rats or 12-30 plants. The utilities include:

- Environmentally controlled life support system (ECLSS)
- 28 VDC (30% of the total power (45kw) is available to experiments)
- Programmable controls
- Coolant loop access
- Down link capability
- Size (approximately 1.2 m wide by 1.0 m deep; the dimensions are still somewhat soft).

Joellen Lashbrook provided further explanation of constraints placed on hardware and experiment design by the STS spacelab requirements. These included:



-a rack envelope of 50 cm width and a depth of approximately 83 cm. The total number of components within this envelope is dependent on the total number of experiments within the payload.

-Each rack is limited in mass which often requires use of aluminum material fabrication.

-Use of "off the shelf" hardware may be eliminated because of potential EMI/EMC interference.

-Immediate data interface is not only limited on launch and recovery (as indicated by Ballard) but is also limited by the fact that even with a dual TDRSS only 65% coverage can be obtained.

Automation was recommended as a goal in design of generic hardware. The automation should allow the crew to explain exceptions. Generic equipment should be designed so as to minimize compromises in experiment design while accommodating a reasonable variety of experiments.

Teri Schnepf provided an overview of the ultimate automation planned for Space Station-Telescience. The goals of telescience are two-fold and include:

- Transaction management which may be used for design and rapid reaction to changes required in experiment design
- Distribution of the traditional Payload Operations Control Center (POCC) functions to remote investigator locations with the additional feature of allowing remote manipulation of the experiments.

As a result of the automation of telescience, it is anticipated the scientific and space station community will reap the benefits of:

- Time and money savings during the design phase
- Crew time saving from incorporation of robotics
- Increased science quality by virtue of investigator interfaces and control of their science.

Ms. Schnepf concluded her presentation by sharing views of the testbedding efforts, i.e., a workstation design, currently in process at the Lockheed Missiles and Space Company.

Wayne Gonzalez, also of Lockheed Missiles and Space Company discussed the "Manned Space-Craft Environments" with emphasis on human factors. The essential rules of experiment preparation for the microgravity man tended environment are:

- Design it out
- Design back ups
- Build in alarms
- Rely on procedures, training, and documentation as last resorts.

Even with automation, the audience was advised to "keep it simple."

Mr. Gonzalez reminded the audience of the rules of multilevel containment, particularly in planning for Space Station which is aiming toward a 100K clean room atmosphere. This means activities should be planned as "glove box manipulations." Because of these constraints on cleanliness and particulates, the friend in microgravity (velcro) will no longer be a prime ingredient due to the potential of shedding.

Audience primary concerns at the end of this session focused on:

- Learning more about equipment which is already available for microgravity experiments; this includes those for both the biological and materials processing disciplines.
- NASA's real acceptance of the telepresence concept, i.e., is NASA willing to give the projected control to the investigator/experimenter community.
- The reality of Lifesat. The concept is good, but how many years will it be before the concept is a reality.

## **SESSION VI: EXPERIMENTAL AND COMMERCIAL APPLICATIONS IN MICROGRAVITY**

**FACILITATOR: L. MILOV**

Increased space life science activity will require not only stronger, more cooperative relationships between private industry and NASA, but it may also induce cooperative partnerships between basic life science research and space commercialization. The presentations in this session are current examples of this growing partnership, which is strongly advocated by the Commercial Life Sciences Working Group.

P. Seshan of Jet Propulsion Laboratory and E. Dunlop of Colorado State University, in separate presentations, reviewed the engineering and design progress associated with bioreactor technology. The potential applications of this technology, its utilization both in space and in basic research conducted here on Earth, was discussed in previous sessions of this Conference. M. Deuser exemplified how personal involvement in a chick embryo Shuttle experiment motivated the entrepreneurship of a small firm specializing in the engineering and design of flight hardware. The potential for osteoporosis in microgravity conditions is the basis for the presentation by S. Smith who was representing a company which specializes in the technology of bone mineral measurements. In a similar vein, M. Luttgies presented work on the development of countermeasures to the biological effects induced by microgravity. An obvious countermeasure is the restoration of a gravity-like state. The data obtained by Luttgies suggest that the deleterious skeletal changes induced by simulated weightlessness can be prevented with pulsed electromagnetic fields. K. Soliman presented his data on the neurological differentiation of adrenal chromaffin cells. If such differentiation can be induced in microgravity, then clinical significance would lie in the potential treatment of Parkinson's patients by transplantation of human cells cultured in microgravity.

Two major points were evident in the presentations and discussions of this session:

- ground-based research involved with cell culture will gain from bioreactor design and development, especially when a scaled down laboratory model becomes available
- spaceflight provides a testbed in which to investigate therapeutic countermeasures to diseases on Earth which are analogous to the physiological adaptations to space, e.g., space and disuse osteoporosis

The Office of Commercial Programs and the Commercial Life Science Working Group are optimistic about the partnerships they advocate. Based upon the network of academic institutions linked to NASA Commercial Centers for the Development of Space, the emerging collaboration of industry and expanded support from the NASA Office of Commercial Programs, interaction between academia, industry and government, has been, and can continue to be, directed toward a productive relationship.

## OPEN DISCUSSION - SESSION VII

K. Souza, Chief of the Life Sciences Payload Office at Ames Research Center, joined the Conference to act as Facilitator of the final session which summarized the concerns and recommendations conveyed in session discussions. Souza returned to the Conference focus by posing the following questions: Is there such a thing as a response of cells to microgravity? Does it make sense to study a cellular response? What kind of hardware do you require for your research? What can the flight program office do to support you?

A. Cogoli, in his session summary, tried to make a distinction between a *sensitive* cell and a *susceptive* cell. Cogoli felt that "sensitive" implied that a specific receptor existed while "susceptive" meant that in some manner the cell manifested a change in response to microgravity. A. Brown insisted that if Cogoli said that no animal cell could sense gravity, implying that no gravity receptor existed, then he was casting doubt as to whether animal research should be conducted in space. Cogoli explained that he was misunderstood and clarified his terminology: a cell may be sensitive to gravity because it possesses a receptor, e.g., statolith. And yet, a cell may not *possess* a receptor but still be susceptible to the effects of gravity. The analogy Cogoli offered was that of the cell responding to a temperature change in its environment without possessing a specific thermometer. He maintained that a change in the environment would necessarily induce a change in the behavior of the cell.

R. Bandurski could not understand how nature while providing perception mechanisms to small fungi such as *Phycomyces* would stop providing receptors as those organisms evolved to higher forms. He warned that the phrasing of our concepts should be thoughtfully worded or else we risked being misunderstood. He suggested shifting the emphasis to *looking* for the gravity receptor. K. Souza, alternatively, suggested stating that no gravity receptor in animal cells has yet been identified. Bandurski, however, proclaimed that there were too many examples of gravitational responses for us to conclude there was no gravity receptor. J. Kessler mentioned that a gravitational receptor was not necessarily a specific, anatomical structure (i.e., protein) but could be a *dynamic system* affected by gravity. He referred to the dynamic processes associated with streaming, translocation, and non-uniform densities.

Subsequently, S. Upton discussed unicellular organisms and their specific organelles for perception. As these unicellular forms evolved to higher organisms these specific organelles were no longer required because they developed into analogs of organs. Tissues, like the inner ear, would sense gravity for the whole body and cells could concentrate on other functions. Gravity did not need to be perceived by a receptor in a single cell because of the cell-cell interactions in tissues. This concept may account for the spurious observations in lymphocytes because suspended lymphocytes had no cell-cell contact. R. Gruener, subsequently, came to the defense of vertebrate and mammalian cells by detailing how the behavioral independence cited in unicellular organisms is also expressed in vertebral and animal cells during embryonic development. P. Todd warranted that the cell was considered to be incapable of gravity perception because it did not possess an "object" which would make itself perceptive but it *did* have a "process" which can do so. G.

Conrad, though, offered cytoskeletal elements as a gravity-sensing objects in eukaryotes. Here is a system of stress-bearing elements (microtubules and microfilaments) which can respond to gravity by changing its polymerization kinetics. This well-characterized sensitivity to environmental changes occurs so rapidly (seconds) that inflight fixation would be mandatory for cell biology research, conducted in space, in order to monitor any effects. A. Brown, in contrast, purported that gravity, being a body force, could not directly affect a *process*, which was a secondary effect, but had to affect an *object*.

Regarding commercialization, A. Brown warned against using the potential for commercialization to rank basic science proposals. While the importance of commercialization should be recognized it should be considered, rather, as a separate flight program so as not to compete with basic science for space missions. K. Souza was in total agreement but admitted that at NASA the Life Sciences Flight Program was totally divorced from the commercial activity. It was the hope and intent of this Conference that this lack of interaction within NASA be reversed. W. Hymer maintained that when investigators have taken the time to see the research being conducted at the industry level, e.g., pharmaceutical industry, they have found out that commercialization competed favorably, if not excelled, what had been conducted in academic communities. Hymer emphasized that the research capability in industry should not be ignored, or commercialization considered a denigration to basic research.

A. Brown offered this insight on generic hardware: the general purpose microscope would not be difficult to developed because of the extensive experience ( $\approx 300$  years) in microscopy which existed. On the other hand, many other pieces of equipment, slated for generic development, do not have as great of background information and it would take many modifications before a model was functional for multiple use. P. Callahan concurred, voicing that, for highly technical or for functionally complicated pieces of equipment, prototypes of components should be made and attempted for several generations before whole pieces of hardware were assembled and generically developed.

When, K. Souza asked if the conference would identify generic hardware by name, G. Conrad expressed the need of cell biologists to make microscopic observations real time with epifluorescence either in manned or unmanned spaceflights. R. Mains suggested totally isolated and automated packages, such as the finger-sized video cameras alluded to in a previous presentation, which could be combined with microscopy, with a method for inflight experiment activation and/or termination capabilities, and with data acquisition and storage. P. Callahan remarked that such a system is available and works well. Souza attested to the Israeli development of a locker-sized incubation for a hornet experiment which installed video equipment for remote operation. P. Todd implied that it is possible, in addition, to develop confocal optics, fluorescence optics, CCD detectors which could fit into the palm of the hand, unlike the size of the microscope Montgomery dealt with on Skylab. (See Attachment F).

In discussing the work of the task force for the Space and Advanced Cytometry Project, P. Todd mentioned the development of the video-driven, image cytometer which would also allow the option of conducting flow image cytometry. The feasibility studies conducted at the University of Rochester with the wide angle confocal system established the potential to manipulate cells by optical trapping with optical forceps. This technology is being currently developed for 1997 for use in the Space Station.

A. Krikorian suggested that bioreactor engineers should scale down bioreactors for bench top operation here on earth. He considered the technology to be marketable within basic science research without the need for space application. K. Souza stated that the message put forth in a recent Bioinstrumentation workshop was that NASA was not the desirable market but, in fact, a vehicle for public relations.

The last comment made by J. Duke in her facilitator summary concerned the need to for the science community to get involved in the budget process to ensure that NASA acquired continued and increased funding. She suggested contacting congressional representatives. R. Gruener agreed, but warned against lobbying for personal projects. K. Souza reminded the audience about the aerospace industry connection. Companies such as Lockheed, McDonnell Douglas and Boeing have better congressional connections than any scientific society.

Responding to J. Duke's desire to see the terminology clarified, R. Bandurski also pitched for the use of better terms in discussing the research in space. He referred to A. Brown's comment that microgravity was the *control* and that 1 g was the *test environment*. As Bandurski detailed, the phrasing should be, rather, the effect of *gravity* on cellular processes. Better defined terms would keep certain parties (like material scientists or funding agencies) from misunderstanding our research program.

In response, J. Kessler offered a modified version of the conference questionnaire which he felt employed better wording (See Attachment D): Can the microgravity environment provide something unique which can not be conducted any other way? The Kessler model of free-swimming organisms, moreover, reminded G. Conrad about the failure of rodents to reproduce in space. He inquired if anyone had examined whether microgravity negatively influences the motility of sperm. P. Todd attested that sperm did swim in microgravity but he was unable to comment on their directional capacity. He added, though, that blood levels of testosterone were significantly reduced in rats. K. Souza, furthermore, said that insects and fish eggs have been fertilized in space.

G. Conrad would like to see NASA interact with the American Society of Cell Biologists. He claimed that it would be a missed opportunity for NASA not to solicit opinions from cell biologists. He maintained, also, that cell biologists, like most scientists, would like to know their chances of receiving funding in a NASA program otherwise they could not consider conducting cell research in space.

R. Bandurski was impressed by the new ideas brought forth in this Conference and cited the work of J. Kessler and B. Taylor. Taylor's presentation of the sophisticated transduction system found in bacterial chemotaxis, inspired models of gravitational force involving a proton motive force. Bandurski was also impressed with the Kessler's free-swimming microorganisms as a system for studying microgravity effects.

In a related discussion, A. Brown commented on how space was originally viewed from two levels: it was either a threat or just one of many levels of g forces. He emphasized that in order to study how microgravity influences life as we know it here on earth we must be cognizant of the severity of space but remain open to explore the whole range of g levels. The only advantage of 1 g is that it is easily accessible, which underscores the use of 0 g controls. K. Souza agreed that those were the two foci of NASA: Basic Research and Astronaut Safety. This anthropocentric outlook, in the past, has made it difficult to justify plant experimentation because it can not be extrapolated back to humans. P. Todd affirmed that, regardless of the intent, the final knowledge is equally important.

In addition, J. Kessler reiterated the need to consult material scientists for developing experimental operations and for interpreting the responses influenced by physical properties and physical interactions.

Concerning the three cell culture systems described (flat plate cultures, flat plate cultures on clinostats and bioreactors), R. Mains asked how specific the results observed in microgravity were for each configuration. It is important to delineate whether generic hardware can support the kind of cell culture desired in space. P. Todd enunciated that the same terms eliminated from a bioreactor transport equation, because of their insignificant contribution, could not be similarly eliminated from the other configurations. J. Duke suggested that the disparity could be dealt with by using cells which could be cultured for all systems.

With regards to the mission and hardware constraints on flight experiments, K. Souza voiced that the conservative approach of the U.S., as opposed to the U.S.S.R., was based upon ignorance. The Soviets did not enforce as stringent precautions and yet they had managed to have cosmonauts in space for better than 300 days. P. Callahan, in addition, remarked that the emphasis on "simple" hardware refers to "not complicated" versus "not complex." Souza added that international support, for developing programs such as LifeSat, can provide enough leverage to ensure survivability.

G. Conrad suggested that a national scientific meeting was a good opportunity for the interfacing of investigators and engineers for hardware development. Such interactions would be facilitated with hands-on prototypes and Conrad asserted that NASA should increase the exposure to models through demonstration booths at meetings. K. Souza mentioned the less-than-receptive response to existing NASA "road shows" but would look into providing a demonstration booth at the ASCB meeting in San Francisco this January. He also commented that prototypes were usually the first eliminated during a budget cut and that hardware directed toward a particular flight was generally sequestered in preparation for flight. A. Krikorian contended,

however, that the opportunity to evaluate a design beyond the blueprint stage was fundamental to the development of generic hardware. Souza stated that NASA would accept unsolicited proposals for generic hardware development and would favor such interests from small businesses. In particular, the SBIR (Small Business Innovative Resources) was an appropriate program for funding projects in the early stages of development and evaluation.

K. Souza also claimed that letters to NASA headquarters, expressing a mandatory need for hardware models, from the PIs themselves would facilitate the funnelling of money in that direction. He reminded the audience that even the provision of plastic mock-ups or non-flight models would require money to pay shop bills. The important point to address was the reason: "for application to the following experiment . . . ." Souza acknowledged that such a request (for a few units, at low cost, for quick testing) would help university PI's in the preparation of a full-fledged proposal. P. Callahan cautioned that the correct terminology to apply was "Flight-like hardware" to avoid testing an inappropriate configuration for its ability to support an experiment. A. Brown also suggested that a unit non-qualified for flight ("lacking the papers") would be inexpensive and contain the same materials to address incompatibility issues.

The need to re-examine critically all experimental data, including the Russian literature, was voiced and underscored by P. Todd. In addition, R. Bandurski concurred that the interaction of physicists and theorists with the gravitational biologists was invaluable for interpreting the influences of physical factors and the occurrences of initial transductions such as the proton motive force.

S. Upton discussed the complementation of *in vitro* work with *in vivo* studies. R. Ballard contended that, although many results existed from rat biospecimen parts experiments, which involved multiple PIs, a consolidation of data was not available. K. Souza confirmed this failing of NASA to develop the appropriate data base.

J. Kessler voiced his ignorance of the available literature on flight experiments and on studies of gravitational biology. When informed that bibliographies existed, he requested the provision of addresses by which the attendees could inquire about distribution of these bibliographies (See Attachment E). K. Souza added that the Conference should substantiate the fundamental need for both a Database and a Bibliography by dictating a formal recommendation.

In a final comment, K. Souza expressed his interest in hearing opinions from conference attendees with regards to the direction NASA should take in conducting cell biology research in space.



CONFERENCE PAPERS

PRECEDING PAGE BLANK NOT FILMED

FUNDAMENTAL RESULTS FROM MICROGRAVITY CELL EXPERIMENTS  
WITH POSSIBLE COMMERCIAL APPLICATIONSC.M. Winget<sup>1</sup>, T.N. Fast<sup>2</sup>, W. E. Hinds<sup>3</sup>, R. L. Schaefer<sup>3</sup>, and  
P. X. Callahan<sup>1</sup><sup>1</sup>Space Life Sciences Payloads Office, <sup>2</sup>University of Santa Clara,<sup>3</sup>Lockheed Engineering & Sciences Company  
NASA Ames Research Center, Mountain View, California

## ABSTRACT

This article presents some of the major milestones for studies in cell biology that have been conducted by the Soviet Union and the United States in the upper layers of the atmosphere and in outer space for more than thirty-five years. The goals of these studies have changed as new knowledge has been acquired and the priorities for the use of microgravity have shifted toward basic research and commercial applications. Certain details concerning the impact of microgravity on cell systems will be presented throughout this Conference. However, it needs to be emphasized that in planning and conducting microgravity experiments, there are some important prerequisites not normally taken into account by the investigating scientist. Apart from the required background knowledge of previous microgravity and ground-based experiments, the investigator should have the understanding of the hardware as a physical unit, the complete knowledge of its operation, the range of its capabilities and the anticipation of problems that may occur. Moreover, if the production of commercial products in space is to be manifested, data obtained from previous microgravity experiments must be used to optimize the design of flight hardware.

## INTRODUCTION

Gravity, the focus of this workshop, is a constant environmental factor in which all living things on Earth evolved for more than 3.5 billion years. The dependence of many living organisms on gravity is self-evident. However, there is a paucity of experimental data which suggest a direct effect of gravity (or its absence - weightlessness) on fundamental biological processes associated with the cell. Although anatomical, physiological and biochemical changes in tissues are known to occur during spaceflight, the causative mechanisms underlying these changes are poorly understood. Furthermore, an understanding of the mechanisms by which the lack of gravity brings about these altered biological responses has both theoretical and practical significance.

This workshop will focus on the modifications of cell function in the altered gravity environment. In addition, experimental data will be examined as it relates to the theoretical analysis of gravitational influences at the cellular level. Since cell research in space will require the development of special hardware, this workshop will also explore the feasibility of the development of generic hardware. Finally, the potential for microgravity cell culture experiments to secrete cell products for use in the therapy of human

diseases provides one perspective for discussions on the commercial opportunities available in space.

Experimental biological studies in the upper layers of the atmosphere and in outer space have been conducted for more than 35 years. The goals of these studies have changed as knowledge about the conditions of outer space increased -- presenting new problems for science and man -- and as the potential use of microgravity in the development of commercial products became more apparent.

The investigations conducted in the 1940s were not focused on technology spin-offs but were stimulated by two relatively new scientific discoveries, i.e., the ionizing radiation of cosmic origin and the mutagenic activity of this radiation. It was assumed that so-called spontaneous mutations were the result of these two physical phenomena and that biological evolution, thereby, must in some way be dependent on ionizing radiation. Thus, the early experiments in microgravity set out to investigate the possible synergism between microgravity and radiation levels and to test the influence of cosmic ionizing radiation on evolutionary process. This issue was recently investigated by Bucker in 1985 on the D-1 mission. A unique aspect of this experiment was the determination that the hatching frequency of an insect egg was slightly reduced in those microgravity-exposed eggs that were also hit by radiation. To our knowledge this is the first experiment that critically addressed and separated the biological consequences of these two key variables in spaceflight (Bucker et al, 1986).

From 1947-1957, both Soviet and American scientists conducted, using sub-orbital test flights, detailed studies on the ionosphere. Heavily instrumented rockets, usually of German design, were used in these studies and included, on some of the flights, biological payloads. While information obtained from these biological experiments subsequently insured the safety of man for earth-orbiting flights, these ballistic missile flights gave virtually no information concerning the effects of microgravity on cellular processes. An example of the inconclusive data generated is from the experiment with Neurospora. Although Neurospora molds showed a surprisingly high level of mutation following a 20-minute suborbital flight, the control molds also had high rates of mutation (DeBusk, 1961).

The early 1960s can be considered the adolescent years for space biology. It was during this time that microgravity research on biological systems was boosted by two large positive forces: i) a returnable microgravity biology laboratory (i.e., spacecraft-satellites that return to earth) was made available to the research scientist, and ii) a defined funding source, The Life Sciences Division, was identified within NASA to investigate, among other responsibilities, the significance of gravity on living systems. The systematic research of biological systems was expanded considerably by these events. Organisms of highly diverse taxonomic orders, from viruses to mammals, were being used, making it possible to evaluate the influence of spaceflight factors, especially weightlessness, on not only the intact organism but also on the tissue, cell and sub-cellular levels. Furthermore, considerable emphasis was placed on the influence of spaceflight factors on the genetic structures of somatic and embryonic cells.

Moreover, there are unique environmental elements that arise on spaceflight and which cannot be created artificially on the ground. These elements - such as the prolonged state of weightlessness, weightlessness combined with ionizing radiation, the absence of natural circadian rhythm cues, and increased radiation background produced by high-energy particles -

are of great importance to the biologist. The biological experiments performed in space on board various spacecraft have been devoted to an evaluation of the effect of these environmental factors on various biological systems.

In particular, adaptation to weightlessness can be considered on several levels. It can be viewed as disruptions in regulatory processes occurring at the level of the organelle, organ or the organism, or with respect to changes in cellular metabolic energy. Moreover, the gravitational effects on the unicellular organism can be considered negligibly small due to their microscopic dimensions of the cell. When the cell or body size increases, gravitational effects may become of ever increasing importance. Nevertheless, we consider unicellular and small free-living organisms as optimal models for studying the effects of weightlessness because the number of their regulatory complexes is small when compared to larger organisms. However, we are also aware that the success of a cell culture experiment would depend primarily on the choice of the cellular system and the scope of information known about the culture of that particular tissue or cellular system. This subject will be addressed further in this Conference.

Results of early experiments which were concerned with the effects of weightlessness on unicellular forms, from the most primitive procaryote to the amoeba, show that viability, genetic processes, morphology and functional indices of vital activity, as a rule, remain essentially unchanged under the influence of the gravitational factor (or weightlessness). However, recent results from microgravity experiments indicate otherwise. The German D-1 Spacelab mission in 1985 carried several cell biology experiments (Naturwissenschaften, 1986) which provided strong, but preliminary evidence, that microgravity has direct effects on living cell metabolism, structure and function. Significant differences were found between 0-G test subjects and 1-G inflight controls.

In order to elucidate the mechanisms and quantify these gravity effects, sufficient numbers of cells must be cultured under carefully controlled conditions to acquire reliable data on cell proliferation rates, metabolism, secretory processes and structural changes. This workshop was designed to present the current data, the current theoretical aspects on the gravity/cell interaction, the hardware being used to support cells in microgravity experiments, and the current thinking for the design of generic flight hardware in order to support cells in microgravity for commercial applications.

As an example, data will be presented in detail which indicate altered functions of pituitary cells and cells of the immune system in microgravity. While these elegant studies need to be confirmed and expanded to include other important cell systems, this basic information will be useful in understanding cellular functions in individuals working for long periods of time in a microgravity environment. Research has explored the possibility that cells, cultured and maintained in space, may provide useful secretory products which could be isolated and purified under microgravity conditions. These microgravity cell culture experiments would provide an opportunity to obtain massive quantities of differentiated cells, or their products, for potential therapeutic application to human diseases. It would be important to compare the secretory activities of cultured cells in a microgravity environment with the secretory functions observed on Earth, since microgravity could result in modification of the formation and release of secretory products. Research on cell secretion conducted in space, moreover, could require the development of special types of hardware.

Cell and tissue culture is a generally recognized method to study the influence of all possible factors and conditions on the physiology and structural organization of plant and animal cells. Because tissues and cells in cultures are free of the influence of integrating systems of the intact organism, it is possible to investigate the "pure" reaction of the cells and tissues to a given influence (i.e., a reaction which is not masked by the neurohumoral control). In addition, cells and tissue cultures retain many of the morphophysiological characteristics which are typical of tissue elements in the organism.

There are data from cell experiments conducted in microgravity which suggest that changes in cell function can be attributed to the weightless environment. Montgomery examined the possible effects of a zero g environment on cultures (1-59 days) of Wistar-38 human embryonic lung cells on Skylab 3. He detects no significant difference in growth curves, DNA microspectrophotometry, phase microscopy and ultrastructural studies when compared to ground control cultures. However, Montgomery failed to acknowledge as significant the fact that WI-38 fibroblasts had consumed 18% less glucose as indicated by the significantly higher glucose levels in conditioned medium (Montgomery, 1977). Furthermore, published work with cultured lymphocytes report a five-fold increase in interferon production in microgravity (Tálas et al, 1983) and an inhibited response of lymphocytes to mitogen under simulated or null gravity conditions (Cogoli et al, 1984; Cogoli et al, 1980). Proliferation, on the other hand, had been stimulated in unicellular organisms cultured in microgravity as evidenced by *Paramecium aurelia* (Tixador et al, 1981). Finally, Hymer et al (1985) document a reduction in the release of Growth Hormone from rat pituitary cells cultured in microgravity. The above are just some of the observations correlated with the culture of cells in microgravity. In addition to the cell cultures, blood, bone marrow and pieces of human and animal skin were sent into space. However, studies of these objects did not provide sufficient information concerning the influence of spaceflight factors.

Regardless of the large number of experiments that have been conducted on tissue cultures in microgravity, thus far, no unambiguous answer has been found concerning the influence of weightlessness on living cells. The reason for this may be based upon the conditions under which the experiments were performed. One such experimental factor may be temperature, which, in the majority of experiments, either varied within wide limits, was far from optimal, or failed to be recorded. Furthermore, temperature is known to produce pronounced cytophysiological and structural changes in the cells, and it also is a determining factor in the recovery of a cell population following "cooling" or "reheating."

## CONCLUSIONS

As suggested by the aforementioned examples, the effect(s) of the microgravity environment at the cellular level is not immediately apparent. It is however a fundamental problem worthy of investigation. Besides interest in the effect of weightlessness on cell morphological and functional cytology, investigations in cell biology may elucidate the physiological and pharmacological responses to microgravity observed in humans. Taking the observed effects on the cell(s) into account, and the theoretical concepts concerning gravitational effects of the cell, we propose that free-living

unicellular organisms are influenced by variations in the magnitude and direction of the gravitational field.

Bucker, H, et al. 1986. *Naturwissenschaften*. Vol.73, 433-434

Cogoli, A. et al. 1980. *Aviat. Space Environ. Med.* 51:29-34.

Cogoli, A. et al. 1984. *Science* 225:228-230.

DeBusk, A.G. 1961., *Aerospace Med.*, 32:925-931.

Hymer, et al. 1985. *The Physiologist*. 28:S197-S198.

Tálas, et al. 1983. *Acta Microbiologica Hungarica*. 1:53-61.

Tixador, et al. 1981. *Biochimica et Biophysica acta*. 649:175-178.

Montgomery, et al. 1977. In: *Biomedical Results from Skylab*. R.S. Johnston and L.F. Dietlein, Eds. NASA, Washington D.C. pp. 221-234.

*Naturwissenschaften*. 1986. 73:400-458.

## THE PITUITARY GROWTH HORMONE CELL IN SPACE

W.C. Hymer  
Penn State University

R. Grindeland  
NASA Ames Research Center

Issues relating to the effects of microgravity ( $\mu\text{G}$ ) on pituitary cell function require an understanding of how these cells are thought to be controlled and function both *in vivo* and *in vitro*. Our experimental designs for spaceflight research have been driven by current ground based research.

Ground based research. The mammalian pituitary is a small, well protected gland that is vitally important for the control of proper body function. A rigorous understanding of that control is hindered by heterogeneities, both cellular and molecular, of different hormone subsystems that we believe exist within the pituitary gland. The fact that there are disproportionate numbers of growth hormone (GH)- and prolactin (PRL)-producing cells must certainly reflect the importance of these two protein hormones in body metabolism. Results of intensive research now make it quite clear that these hormones are multifunctional. In the case of GH, for example, the hormone is a) involved in metabolism of fat, carbohydrate and protein and b) has receptors for GH that can be found on numerous tissues such as bone, muscle, liver and cells of the immune system. In light of these diverse biological activities, the idea that a single GH assay might not detect all of them is not surprising. Thus, hormone assays based on immunological techniques, while being easy and relatively inexpensive, may not always yield correct potency estimates (Ellis and Grindeland, 1974). Ongoing work in our laboratories unequivocally demonstrate that GH cells are heterogeneous with regard to the biological activity of the hormone they secrete (Grindeland, R. and W.C. Hymer. Differential Release of Bioreactive to Immunoreactive Growth Hormone from Separated Somatotrophs. Proc. Soc. Exp. Bio. Med. Manuscript submitted.).

In addition to heterogeneity of GH activities and GH cells, heterogeneities also exist within the GH molecules themselves. For example, alternative splicing of the GH mRNA results in two variants that may have different biological activities. Furthermore, post-translational modifications such as phosphorylation, proteolytic cleavage, glycosylation and disulfide aggregation are known to occur within the gland (Lewis, 1984). Apart from one recent abstract (Farrington and Hymer, 1988) a positive correlation between these cellular and molecular heterogeneities has yet to be made.

While the foregoing comments relate to GH once released from the cell, it is important to know that sensitive techniques are now available to study GH cells themselves. For example, it is possible to 1) objectively categorize 30,000 cells by flow cytometry to determine percentages of GH cells in a suspension (Hatfield, and Hymer, 1985); 2) obtain information concerning the cells internal structure by laser flow cytometry (Hatfield, and Hymer, 1986a; Hatfield and Hymer, 1986b) 3) quantitatively measure hormone release from single cells (Kendall and Hymer, 1987); 4) isolate GH cells and GH cell subpopulations (Snyder et al, 1977); 5) maintain GH cells in culture in either serum-containing or serum-free media (Grindeland et al, 1987) and

PRECEDING PAGE BLANK NOT FILMED

finally 6) implant GH cells into the living animal using hollow fiber technology (Hymer et al, 1981) to determine the effects of the secreted GH *in vivo*.

Since the subject of this conference relates to  $\mu$ G effects directly at the cellular level, it is particularly important to understand the rationale and ramifications underlying the hollow fiber procedure. In this technique living cells ( $2 \times 10^5$ ) are injected (1.5  $\mu$ l) into the lumen of a 10 mm XM-50 fiber and sealed-in using wax on the fiber ends. The fibers are implanted into the brains of hypophysectomized rats in such a way that the fiber courses through the lateral ventricles and is bathed in cerebral spinal fluid. This fluid is rich in a peptide (GRF) that can stimulate the encapsulated GH cells to release hormone from the fiber into the recipient's bloodstream so that the biological consequences of the hormone can be assessed by measurement of the tibial epiphyseal plate width some 10 days post-implantation.

Results of pituitary cell spaceflight research. Three experiments have been done to date; 1) STS-8 (1983); 2) SL-3 (1985) and 3) Cosmos 1887 (1987). In two cases pituitary glands, obtained from male rats that had flown in  $\mu$ G for 7 days (SL-3) or 13 days (Cosmos 1887), were used to prepare cells for subsequent study on Earth. In the other experiment, dispersed cells were maintained in a closed tube containing culture medium and serum at 37 ° C in a middeck locker. On return, the cells were recovered and cultured in fresh serum-containing medium for 6 days to determine what effect exposure to  $\mu$ G might have on the ability of the cell to release GH.

The results of these 3 experiments are summarized in Table 1. Details of each experiment can be found in (Hymer et al, 1987; STS-8), (Grindeland et al, 1987; SL-3) and (Hymer WC, Grindeland R, Krasnov I, Sawchenko P, Victorov I, Vale, W, Motter K and Vasques M. Changes in Pituitary growth hormone cells prepared from rats flown on Cosmos 1887. Manuscript submitted). Clearly, exposure to  $\mu$ G subsequently affected GH release from the pituitary cell. Since most of our data come from rats that have "flown" in space, it is tempting (at first glance) to attribute the results to physiological effects at the organ/systemic level; for example, changes in fluid shifts, microcirculation, non-specific stress and the like. Closer inspection of our results, however, support the counter hypothesis that exposure to the unique environment of space affects secretory processes directly at the level of the pituitary cell. The arguments are:

- implantation of cells from flight rats into hypophysectomized rats, under conditions where flight cells could be maximally stimulated to release GH, clearly did not. This suggests a "secretory defect" within the flight cell that was maintained on subsequent testing in vivo.
- culture of cells from flight rats consistently showed partial shutdown of GH release.
- continued culture of cells that "flew" in space also showed shutdown of GH release on Earth.

What intracellular mechanisms could account for the effect? Some of the more obvious targets are a) the microtubular system; b) the GH packing system (golgi/secretory granule) and c) plasma membrane receptor defects. Since the fluorescence staining intensity of the GH cell is increased (Table 1), we currently favor the hypothesis that hormone packaging is a likely target.



However, microtubule "motors" drive the granules out of the cell and receptor function is likely to be mechanically coupled to these motors. Future experiments will test these various possibilities.

Since GH controls the function of other systems (bone, muscle, immune) which are themselves affected by  $\mu\text{G}$ , our research is relevant to the issue of long-term manned spaceflight.

## References

- Ellis J and R. Grindeland. 1974. Dichotomy between bioassable and immunoassayable growth hormone. In *Adv. in Human GH Research*. S. Raiti ed., Washington D.C., U.S. Govt. Printing Office, 409.
- Farrington, M. and W.C. Hymer.. Characterization of high molecular weight aggregates of rat GH. 70th Meeting of Endocrine Society. June 1988. Abs. 239.
- Grindeland, R, W.C. Hymer, M. Farrington, T. Fast, C. Hayes, K. Motter, L. Patil and M. Vasques.. 1987. Changes in pituitary growth hormone cells prepared from rats flown on Space Lab 3. *Am. J. Physiol.* 252:209-215.
- Hatfield, J.M. and W.C. Hymer. 1986. Flow cytometric immunofluorescence of rat anterior pituitary cells. *Cytometry* 6:137-142.
- Hatfield, J.M. and W.C. Hymer. 1986a. Flow cytometric analysis and sorting of live male rat anterior pituitary cell types by forward angle and perpendicular light scatter. *Endocrinology.* 119:2670-2682.
- Hatfield, J.M. and W.C. Hymer. 1986b. Flow cytometric analysis and sorting of live female rat anterior pituitary cell types by forward angle and perpendicular light scatter: Effect of 17 $\beta$ -Estradiol. *Endocrinology.* 119:2683-2694.
- Hymer, W.C., D. Wilbur, R. Page, E. Hibbard, R. Kelsey and J. Hatfield. 1981. Pituitary hollow fiber units in vivo and in vitro. *Neuroendocrinology.* 32:339-349.
- Hymer, W.C., R. Grindeland, C. Hayes, J. Lanham and D. Morrison. 1987. Life sciences, biotechnology and microgravity. In *Advances in the Astronautical Sciences*. Vol. 61. Edited by GW Morgenthaler, GL May, WK Tobiska and JN Koster. American Astronautical Society by Univelt, Inc. 1333-1345.
- Kendall, M. and W.C. Hymer. 1987. Cell Blotting: A new method for quantifying hormone release from single rat pituitary cells. *Endocrinology.* 121:2260-2262.
- Lewis, U. 1984. Variants of growth hormone and prolactin and their posttranslational modifications. *Ann. Rev. Physiology.* 46, 33.
- Snyder, G, W.C. Hymer and J. Snyder. 1977. Functional heterogeneity in somatotrophs isolated from the rat anterior pituitary. *Endocrinology.* 101:788-799.

TABLE 1

Summary of results of three spaceflight experiments concerned with effects of  $\mu\text{G}$  on pituitary growth hormone cell function.

QUESTION	METHOD	FLIGHT	RESULTS
1. Is GH release affected <u>in vitro</u> ? (immunoassay)	Cell Culture	STS-8	Yes. Reduced 20 fold
	"	SL-3 1887	Yes. Reduced by ~ 50%. Yes. Reduced by ~ 30%.
2. Is GH release affected in vitro? (bioassay)	HPLC of culture media-3T3 cell bioassay	SL-3	Yes. Activity of high molecular weight hormone reduced.
	Tibial assay of culture media	1887	Yes. Activity reduced by ~ 50%
3. Is GH release affected in vivo? (bioassay)	Hollow fiber Implantation	SL-3	Yes. Reduced by ~ 50%.
	"	1887	Yes. Reduced by ~ 50%.
4. Is the percentage of GH cells affected?	Laser flow immuno-fluorescence	SL-3	No.
	"	1887	No.
5. Is the size of the GH cell affected?	Laser light scatter	SL-3	No.
	"	1887	No.
6. Is the GH fluorescence staining intensity affected?	Laser flow immuno-fluorescence	SL-3	Yes. Increased about 16%/cell
	"	1887	Yes. Intensity doubled/cell
7. Are the variant forms of GH affected?	Western blotting	SL-3	No.

RESPONSE OF LYMPHOCYTES TO A MITOGENIC STIMULUS DURING  
SPACEFLIGHT

Gerald Sonnenfeld  
Department of Microbiology and Immunology  
and  
Department of Oral Health,  
Schools of Medicine and Dentistry  
University of Louisville  
Louisville, KY 40292

## ABSTRACT

Several studies have been carried out that demonstrate that immunological activities of lymphocytes can be affected by spaceflight or by models that attempt to simulate some aspects of weightlessness. Included among these are the responses of lymphocytes to external stimuli such as mitogens and viruses. When cultures of lymphocytes were flown in space, the ability of the lymphocytes to respond to mitogens was inhibited. Similar results were obtained when lymphocytes from astronauts or animals just returned from space were placed into culture immediately upon return to earth, and when models of hypogravity were used. Lymphocytes placed in culture during spaceflights produced enhanced levels of interferon compared to control cultures. When cultures of lymphocytes were prepared from cosmonauts or rodents immediately upon return to earth, interferon production was inhibited. These results suggest that space flight can have profound effects on lymphocyte function, and that effects on isolated cells may be different from that on cells in the whole organism.

## INTRODUCTION

Over the years, it has become apparent that spaceflight can have profound effects on biological systems. Included among those systems is the immune system of mammals (Barone and Caren, 1984; Jackson and Warner, 1986). In most cases, suppression of immune responses has occurred, but there have been occasional reports of immune enhancement (Barone and Caren, 1984; Jackson and Warner, 1986). Similar results have occurred when ground-based models of weightlessness have been utilized.

The mechanism of the effects of spaceflight on immune responses remains to be established. Weightlessness, stress, and low-level radiation could all contribute to alterations in immune responses. Although studies on the effects of spaceflight on immune responses have been limited, some interesting observations have been made. In this monograph, I will review the effects of spaceflight and modeling of weightlessness on lymphocyte function as determined by the response of the lymphocytes to external stimuli such as mitogens.

EFFECTS OF SPACEFLIGHT AND MODELING ON THE BLASTOGENIC RESPONSE OF  
LYMPHOCYTES

Several studies have been carried out by obtaining the blood of astronauts/cosmonauts immediately after return from spaceflight. Blood was

PRECEDING PAGE BLANK NOT FILMED

also obtained from astronauts and cosmonauts before flight, and in some cases, during flight, to allow for the determination of the kinetics of changes in immune responsiveness. In these experiments, white blood cells were separated from the blood and placed in tissue culture. Mitogens, such as phytohemmagglutinin or concanavalin-A were added to the cultures. Over time, lymphocytes from normal individuals would divide and incorporate  $^3\text{[H]}$ -thymidine, indicating a blastogenic response of the lymphocytes to the mitogen. The blastogenic response to lymphocytes requires interaction with another cell type, the macrophage, as well as interaction with soluble regulatory factors known as cytokines. The blastogenic response and the production of cytokines are indications of a normal functioning immune system.

Several experiments were carried out to determine the effects of spaceflight on lymphocyte blastogenesis. In most cases (Table 1), the blastogenic response of lymphocytes to mitogens was inhibited severely in cells obtained from individuals immediately after return to earth (Fischer et al., 1972; Kimzey et al., 1975 and 1976; Criswell and Cobb, 1977; Lesnyak and Tashputalov, 1981; Taylor, 1983; Taylor and Dardano, 1983; Konstantinova et al., 1985; Taylor and Neale, 1986). The duration of the flights was from several days to several months. Recent reports (Taylor, 1983; Taylor and Dardano, 1983; Taylor and Neale, 1986) have also indicated decreased levels of circulating monocytes in astronauts after spaceflight (Table 1). Since the monocyte is an important accessory cell for the blastogenic response of lymphocytes, this could have contributed to the suppression observed.

While the results described above indicate that blastogenesis of lymphocytes in response to mitogens was inhibited when the cells were taken from individuals immediately after return from space, the question still remained whether spaceflight could affect blastogenesis of lymphocytes actually held in tissue culture during spaceflight. This question was addressed by a series of experiments using simulation and actual flight studies carried out by Cogoli and his associates.

Human peripheral blood leukocytes were placed in culture in a fast-rotating clinostat. This clinostat has constantly changing gravity vectors, and has been used as a technique for simulating microgravity conditions (Cogoli et al., 1980). Lymphocyte blastogenesis was inhibited greatly when the cells were maintained in this clinostat (Table 2) (Cogoli et al., 1980).

In addition, an incubator was developed that allowed the performance of similar experiments during spaceflight. A drastic inhibition of lymphocyte blastogenesis was observed when human peripheral blood leukocytes were placed in culture and challenged with mitogen during space flight (Table 2) (Cogoli and Tschopp, 1984 and 1985; Tschopp and Cogoli, 1984). When the cells were incubated in a 1 G centrifuge during spaceflight, much of the blastogenic capacity was retained (Table 2), indicating that the microgravity conditions of spaceflight contributed to the inhibited blastogenesis that was observed during spaceflight (Cogoli and Tschopp, 1984 and 1985; Tschopp and Cogoli, 1984).

#### EFFECTS OF SPACEFLIGHT AND MODELING ON THE PRODUCTION OF INTERFERON AND OTHER CYTOKINES BY LYMPHOCYTES

Several experiments were also carried out to determine the effects of spaceflight on cytokine production by lymphocytes after mitogenic or antigenic stimulus. Cytokines are molecules that are produced by cells that are

important messengers for the development of immune responses. Without them, lymphocytes and monocytes cannot communicate effectively with each other and immune responses cannot be mounted. The cytokines that have been utilized for space studies are the interferons, important antiviral, anti-cancer and immunoregulatory molecules, and interleukin-3, an important immunoregulatory molecule.

In an Hungarian-Soviet study, blood was removed from cosmonauts and peripheral blood leukocytes were placed in culture during spaceflight (Talas et al., 1983 and 1984). When the cells were challenged with a variety of mitogens and other interferon inducers such as purified protein derivative of Mycobacterium tuberculosis, Newcastle disease virus, and polyriboinosinic-polyribocytidylic acid, interferon-alpha production was enhanced compared to ground controls (Table 3). However, when peripheral blood leukocytes were harvested from cosmonauts immediately upon return to earth after spaceflight, interferon-alpha production in response to Newcastle disease virus challenge of leukocytes was inhibited severely (Table 3) (Talas et al., 1983 and 1984). The number of replicates in this series of experiments was small, and extensive time course experiments to determine how interferon production would have varied in cell cultures from the same individuals on the ground were not carried out. Nevertheless, these experiments suggest that the in vitro response of lymphocytes to spaceflight may differ from the effects of spaceflight on lymphocytes of the intact host.

Inhibited interferon production after simulated weightlessness and spaceflight of animals was also observed. In the first set of experiments, rats and mice were maintained in an antiorthostatic, hypokinetic, hypodynamic suspension system that models some aspects of weightlessness (Morey-Holton and Wronski, 1981; Musacchia et al., 1980; Steffen et al., 1984). In this model, the rodents are suspended with a head-down tilt and no load bearing on the hind limbs. This results in simulation of some of the effects of microgravity. When the mice or rats were challenged with polyriboinosinic-polyribocytidylic acid, there was inhibited interferon-alpha/beta production in antiorthostatically suspended rodents compared to normally housed controls (Table 4) (Sonnenfeld et al., 1982; Rose et al., 1984). The inhibition was transient, as a return to normal caging after suspension resulted in recovered ability to produce interferon. Suspension in an orthostatic fashion (no-head down tilt), which does not simulate the effects of microgravity, had no effect on the capacity of mice to produce interferon-alpha/beta (Table 4) (Rose et al., 1984). It must be noted that when animals are challenged systemically with an interferon inducer such as polyriboinosinic-polyribocytidylic acid, many cell types other than lymphocytes can be induced to produce interferon-alpha/beta. Therefore, these experiments went beyond just measuring the effects of suspension on lymphocyte responses to mitogenic stimuli.

In a second series of experiments, rats were flown in Space Shuttle SL-3. Upon return to earth, spleen cells containing lymphocytes were harvested, placed in culture, and challenged with the mitogen concanavalin-A (Gould et al., 1987). After the appropriate period of incubation, the cell culture supernatant fluids were harvested and assayed for production of two cytokines, interferon-gamma and interleukin-3. Interleukin-3 is another important messenger produced by lymphocytes after mitogenic challenge, providing immunologically significant signals to cells (Gould et al., 1987). Cells from rats that had been flown for one week showed very significant inhibition of the production of interferon-gamma, but no effect on

interleukin-3 production (Table 5) (Gould et al., 1987). The results with the interferon-gamma supported previous findings in human flight and rodent suspension studies indicating that interferon-alpha/beta was inhibited. However, the lack of effect of spaceflight on interleukin-3 production indicates that all responses of lymphocytes to mitogens are not affected in the same fashion by spaceflight.

## CONCLUSIONS

The studies described above indicate that spaceflight and models that simulate microgravity can have profound effects on the response of lymphocytes to mitogens. The effects of spaceflight appear to be selective, in that all responses of lymphocytes to mitogens are not affected in a similar fashion. In addition, the effects of spaceflight on isolated lymphocytes in culture may differ from effects when lymphocytes are *in vivo* in a whole animal surrounded by other cells, soluble messengers and interact with systems other than the immune system.

The mechanism of the effects of spaceflight on immune responses remains to be established. Several possibilities exist. Among them are: 1) direct effects of microgravity on lymphocytes, 2) inability of lymphocytes to interact directly with other cell types such as monocytes/macrophages, 3) inability of lymphocytes to produce cytokines, 4) inability of lymphocytes to respond to signals from cytokines, 5) inability of antigenic or mitogenic signals to reach lymphocytes because of fluid-shifts induced during spaceflight, and 6) impaired function of lymphocytes because of faulty interaction with other non-immunological systems such as the neuroendocrine system. Other potential mechanisms surely exist. The study of these mechanisms should progress with time.

Determination of the effects of spaceflight on lymphocytes should yield other fascinating information. Since the immune system is responsible for resistance to infection, the study of lymphocytes should help to determine if long-term exposure to spaceflight conditions could compromise resistance. The ability to produce large amounts of cytokines as a result of genetic engineering probably indicates that enhanced production of cytokines as a result of spaceflight will not be an effective technique for mass production of cytokines. However, studying the response of lymphocytes to spaceflight may aid in our understanding of how the immune response is regulated and may allow the discovery of new cytokines whose actions are masked in normal ground conditions.

## ACKNOWLEDGEMENTS

The studies performed in the author's laboratory were funded in part by grants NCC2-213, NAG9-181 and NAG9-234 from the National Aeronautics and Space Administration.

## REFERENCES

- Barone, R.B. and L.D. Caren. 1984. The immune system: effects of hypergravity and hypogravity. *Aviat. Space Environ. Med.*, vol. 55, pp. 1063-1068.
- Cogoli, A.; M. Valluchi-Morf, M. Meuller and W. Brielib. Effect of hypogravity on human lymphocyte activation. 1980. *Aviat. Space Environ. Med.*, vol. 51, pp. 29-34.
- Cogoli, A., P. Tschopp, and P. Fuchs-Bislin. 1984. Cell sensitivity to gravity. *Science*, vol.225, pp. 228-230.
- Cogoli, A. and P. Tschopp. 1985. Lymphocyte reactivity during space flight. *Immunol. Today*, vol. 6, pp. 1-4.
- Criswell, B.S. and K. Cobb. 1977. Cellular immune response. Apollo-Soyuz Test Project-Summary Science Report. NASA SP-412, pp. 257-262.
- Fischer, C.L., J.C. Daniels, W.C. Levin, S.L. Kimzey, E.K. Cobb, and S.E. Ritzman. 1972. Effects of the space flight environment on man's immune system: II Lymphocyte counts and reactivity. *Aerospace Med.*, Vol. 43, pp. 1122-1125.
- Gould, C.L., M. Lyte, J.A. Williams, A.D. Mandel and Sonnenfeld, G. 1987. Inhibited interferon-gamma production but normal interleukin-3 production from rats flown on the space shuttle. *Aviat. Space Environ. Med.*, vol. 58, pp. 983-986.
- Jackson, A.L. and N.L. Warner. 1986. Preparation, staining and analysis by flow cytometry of peripheral blood leukocytes. In: *Manual of Clinical Laboratory Immunology*, 3rd. ed., N.K. Rose and J.L. Fahey, eds., American Society for Microbiology, Washington, D.C., pp. 226-235.
- Kimzey, S.L., S.E. Ritzman, C.E. Mengel and C.L. Fischer. 1975. Skylab experiment results: hematology studies. *Acta Astronautica*, vol. 2, pp. 141-154.
- Kimzey, S.L., P.C. Johnson, S.E. Ritzman and S.E. Mengel. 1976. Skylab hematology and immunology studies: The second manned mission. *Aviat. Space Environ Med.* Vol. 47, pp. 383-390.
- Konstantinova, I.V., E.N. Antropova, M.P. Rykova, O.A. Guseva, A.T. Lesnyak, I.E. Vorotnikova, and E.F. Vasilyeva. 1985. Cell-mediated and humoral immunity is cosmonauts exposed to space flight factors. *Vestnik. Akad. Med. Nauk CCCP*, No. 8, pp. 51-58.
- Lesnyak, A.T. and R. Yu. Tashputalov. 1981. Effects of space flight on lymphocyte transformation in Cosmonaut's peripheral blood. *Komich. Biol.*, vol. 1, pp. 32-34.
- Morey-Holton, E. and T.J. Wronski. 1981. Animal models for simulating weightlessness. *Physiologist*, vol. 24, pp. 545-548.



- Musacchia, X.J., J.R. Deavers, G.S. Meininger, and T.P. Davis. 1980. A model for hypokinesia: effects on muscle atrophy of the rat. *J. Appl. Physiol.*, vol. 48, 1980, pp. 479-486.
- Rose, A., J.M. Steffen, X.J. Musacchia, A.D. Mandel, and G. Sonnenfeld. 1984. Effect of antiorthostatic suspension on interferon-alpha/beta production by the mouse. *Proc. Soc. Exp. Biol. Med.*, vol. 177, pp. 253-256.
- Sonnenfeld, G. E.R. Morey, J.A. Williams and A.D. Mandel. 1982. Effect of a simulated weightlessness model on the production of rat interferon. *J. Interferon Res.*, vol. 2, pp. 467-470.
- Steffen, J.M., R. Robb, M.J. Dombrowski, X.J. Musacchia, A.D. Mandel and G. Sonnenfeld. A suspension model for hypokinetic/hypodynamic and antiorthostatic responses in the mouse. 1984. *Aviat. Space Environ. Med.*, vol. 55, pp. 612-616.
- Talas, M., L. Batkai, I. Stoger, K. Nagy, L. Hiros, I. Konstantinova, M. Rykova, I. Mosgovaya, O. Guseva and V. Kohzarinov. 1983. Results of space experiment program "interferon" I. Production of interferon *in vitro* by human leukocytes aboard space laboratory Soyuz-6 ("Interferon-I") and influence of space flight on lymphocyte function of Cosmonauts ("Interferon-III"). *Acta Microbiol. Hungarica*, vol. 30, pp. 53-61.
- Talas, M., L. Batkai, I. Stoger, K. Nagy, L. Hiros, I. Konstantinova, M. Rykova, I. Mosgovaya, O. Guseva and V. Kozharinov. 1984. Results of space experiment program "Interferon". *Acta Astronautica*, vol. 11, pp.379-386.
- Taylor, G.R. 1983. Hematological and immunological analysis in shuttle OFT medical report. Technical memorandum 58252, NASA. Washington, D.C.
- Taylor, G.R. and J.R. Dardano. Human cellular immune responsiveness following space flight. *Aviat. Space Environ. Med.*, vol 54 supp. 1, pp. 555-559.
- Taylor, G.R. and L.S. Neale. 1986. Immunological analysis of U.S. Space Shuttle crew members. *Aviat. Space Environ. Med.*, vol. 57, pp. 213-217.
- Tschopp, P. and A. Cogoli, A. 1984. Low gravity lowers immunity to disease. *New Scientist*, vol. 102, p. 36.

TABLE 1

EFFECTS OF SPACEFLIGHT ON THE ABILITY OF SUBJECTS' CELLS TO RESPOND TO MITOGENS UPON RETURN TO EARTH

<u>Effect on Blastogenesis</u>	<u>Effect on Monocyte Number</u>	<u>Reference</u>
None	Not Tested	Fischer, 1972
Inhibited	Not Tested	Kimzey, 1975-6 Criswell, 1977 Lesnyak, 1981 Konstantinova 1985
Inhibited	Decreased	Taylor, 1983, 1983, and 1986

TABLE 2

EFFECTS OF SPACEFLIGHT ON IN VITRO BLASTOGENESIS

<u>Effect on Blastogenesis</u>	<u>Effect of Centrifugation</u>	<u>References</u>
Inhibited	Restored	Cogoli, 1984 and 1985  Tschopp, 1984
HYPOGRAVITY DUE TO CLINOSTAT ON THE GROUND		
Inhibited		Cogoli, 1980

TABLE 3

EFFECT OF SPACEFLIGHT ON HUMAN INTERFERON PRODUCTION

<u>Situation</u>	<u>Effect on Interferon-Alpha</u>	<u>Reference</u>
Leukocytes in Culture in Space	Enhanced	Talas, 1983 and 1984
Leukocytes Harvested after Return from Space	Inhibited	Talas, 1983 and 1984

TABLE 4

EFFECTS OF ANTIORTHOSTATIC SUSPENSION ON INTERFERON PRODUCTION

<u>Treatment</u>	<u>Effect on Interferon-Alpha/Beta</u>	<u>Reference</u>
Rat - 2 week	Inhibited	Sonnenfeld, 1982
Mouse - 1 week	Inhibited	Rose, 1984
Mouse - 1 week + 1 week normal cage	Recovered	Rose, 1984
Mouse - 1 week orthostatic suspension	None	Rose, 1984

TABLE 5

EFFECT OF SPACEFLIGHT ON RAT CYTOKINE PRODUCTION

<u>Duration of Flight</u>	<u>Cytokine</u>	<u>Effect</u>	<u>Reference</u>
1 week	Interferon-gamma	Inhibited	Gould, 1987
1 week	Interleukin-3	Normal	Gould, 1987

POLARITY ESTABLISHMENT, MORPHOGENESIS AND  
CULTURED PLANT CELLS IN SPACE

A.D. Krikorian  
Department of Biochemistry  
State University of New York at Stony Brook  
Stony Brook, New York 11794-5215

## ABSTRACT

Plant development entails an orderly progression of cellular events both in terms of time and geometry (dimensional space). There is only circumstantial evidence that, in the controlled environment of the higher plant embryo sac, gravity may play a role in embryo development. We still do not know whether or not normal embryo development and differentiation in higher plants can be expected to take place reliably and efficiently in the micro g Space environment. It seems essential that more attention be given to studying aspects of reproductive biology in order to be confident that plants will survive "seed to seed to seed" in a Space environment. Until the time arrives when successive generations of plants can be grown, the best we can do is utilize the most appropriate systems and begin, "piece meal," to accumulate information on important aspects of plant reproduction. Cultured plant cells can play an important role in these activities since they can be grown so as to be morphogenetically competent, and thus can simulate those embryogenic events more usually identified with fertilized eggs in the embryo sac of the ovule in the ovary. Also, they can be manipulated with relative ease. The extreme plasticity of such demonstrably totipotent cell systems provides a means to test environmental effects such as micro g on a potentially "free-running" entity. The successful manipulation and management of plant cells and propagules in Space also has significance for exploitation of biotechnologies in Space since such systems, perforce, are an important vehicle whereby many genetic engineering manipulations are achieved.

Introduction. Since all biological development has evolved in the presence of an Earth 1 g vector, it may be argued that gravity plays a role in plant development. Edmund Sinnott even queried as far back as 1960 in his book "Plant Morphogenesis" whether the plant body as we know it could develop in the absence of specific gravitational stimuli or cues (Sinnott, 1960, p. 355). The term gravimorphogenesis is increasingly being used to designate the emerging discipline of the relationship of gravity to development. Some key questions as they apply to plants that need to be addressed include: "Do the cells of plants require gravity and/or other orienting forces at any stage in morphogenesis? What constitutes the or a minimal gravimorphogenetically responsive unit? Can totipotent cells function as a gravireceptor? Can pulses at certain g levels be enough to compromise or ruin a gravimorphogenesis-type experiment in Space or under microgravity conditions? etc.

By using test systems at different levels of initial organization, but which are capable of attaining or achieving the most advanced levels of higher morphogenesis, we should be able to evaluate and even pinpoint the threshold levels where the first detectable responses emerge. The Space environment offers unique opportunities to try to erase and to reapply g signals in proving the relationship of gravity to development. As opportunities for flight

PRECEDING PAGE BLANK NOT FILMED

experimentation increase, and especially as Space Station "Freedom" and other long duration near-0 g environments become available for gravimorphogenetic testing, the prediction is made that it will be proven that gravity is indeed a morphogenetic determinant.

Gravity and Embryo Development in Plants. The early cell divisions that partition the plant zygote into a multicellular tissue mass and lead ultimately to the orderly differentiation of organs are extremely important to organized development. Anatomical and morphological studies of embryogenesis in a variety of plants, both lower and higher, have demonstrated that the earliest division planes establish directionality for growth of the plant axis. The initial divisions are especially significant since their appearance often provides the first external sign that polarity has been determined. In certain plants polarity may be evident in the zygotic cytoplasm prior to the initial division, but for most plant embryos the axis of growth is fixed at the time the zygote is partitioned (cf. Wardlaw, 1955 p. 160; 1965a and b; Raghavan, 1986).

Much attention has been directed towards analyzing the phenomenon of embryo polarity but we still have little knowledge of the factors influencing the planes of early cell divisions. Also, nothing is yet known about the genetic regulation of polarity in plant embryos, and the relationship between molecular, cellular and environmental factors in establishing polarity is obscure. However, the bulk of available data support the thesis that initiation of polarity and determination of the plant axis is one of the earliest events in embryogenesis. The data further support the concept that factors influencing polarity can alter the development (cf. Wardlaw, 1955; Barlow and Carr, 1984).

Internal and external factors both play a role in determining polarity. For free swimming plant zygotes such as those of Fucus there is abundant experimental evidence that polarity can be influenced by a variety of environmental factors including light, temperature, nutrients, pH and mineral gradients (cf. Brownlee and Wood, 1986 and references there cited). There is, in addition, evidence that induced internal gradients can determine polarity. The development of zygotes in archegonia or embryo sacs is somewhat complicated by surrounding maternal tissues which is thought to influence polarity. (See also Willemse, 1981 for a discussion of polarity and megasporogenesis and megagametogenesis.) Whether or not the influence of the surrounding tissue is physical or physiological or both is not known. There is also evidence suggesting that treatments which affect the relationship between enclosed zygotes and surrounding tissue can alter polarity and subsequent development of the embryo.

Gravitational forces often have been observed to have profound influences on embryos of lower vascular plants (cf. LaMotte, 1937). Although many attempts have been made to assess accurately the role of gravity in the induction of embryo polarity and axis determination, the studies are generally inconclusive. In most of the work where centrifugation was used, stratification of the cytoplasm was commonly seen. However, in some cases the initial partitioning of the embryo and its later organization was altered, while in other cases there were no changes. Satisfactory control experiments were not always conducted and the significance of much of the published observations is not clear. In other studies zygotes were grown in various positions with respect to gravity or they were fixed in a substrate and grown on horizontal clinostats to determine if embryo orientation (development) was influenced. These studies are not sophisticated either in their design or in their execution but results often demonstrated that embryo polarity and the orderly segmentation pattern leading to normal development of the plant axis

were altered. Admittedly, there is insufficient evidence to permit any firm conclusions to be made concerning gravity effects on plant embryogenesis. Nevertheless, the preliminary data suggest that gravity may be important to normal embryogenesis and that plant embryo polarity, axis determination and pattern development could be adversely affected in Space.

Systems for Studying Embryogenesis in Space. A study of the influence of a microgravity environment on the early events of reproductive cell and zygote development would contribute substantially to a general understanding of regulatory factors in early plant morphogenesis. Equally important, results from such a study could provide a beginning for a clearer understanding of the behavior of plants grown in the environment of Space (cf. Keefe and Krikorian, 1983; Krikorian et al., 1984; Halstead and Dutcher, 1987). For this type of developmental analysis, intact flowering plants would in my view be the preferred material to study but this is not readily feasible because of the current lack of reliable information concerning most aspects of their reproductive biology in the Space environment. For most flowering plants nothing is known about pollen tube growth, sperm cell migration and the fertilization mechanism as they occur in a microgravity environment (cf. Halstead and Dutcher, 1984, 1987 and references there cited).

Also, and for the foreseeable near-term, duration of Space flights will be relatively short and thus the possibility of carrying out a "seed to seed to seed" type of experiment (cf. Keefe and Krikorian, 1983; Krikorian et al., 1984) will not be possible even using a so-called tachyplant or fast-cycling plant such as the Crucifer Arabidopsis (cf. Ivanov, 1974).

Our approach, therefore, has been to use cultured plant cell systems which are capable of undergoing organized development (i.e., somatic embryogenesis) in vitro. Such systems provide several advantages. These include the fact that large numbers of cells and organizing units can be manipulated for experimentation. Excision of developing plant embryos from seeds in equivalent numbers would be very difficult, if not impossible. Certainly, removal of fertilized eggs or zygotes from the embryo sac in the ovule of higher plants is out of the question. Indeed, it will be a landmark achievement when a zygote so removed can be nurtured to full maturity. In addition to such practical considerations, we have adopted the view that in vitro systems involving totipotent or morphogenetically competent cells present other advantages for proving questions involving higher plant development--especially in Space. Free cells in vitro, unlike cells in the strictly controlled environment of the embryo sac in ovules should be more responsive to perturbations such as those that might exist in micro g. We hypothesize that there should be no highly controlled environment other than that extant in the "genetic program" (whatever that may really mean) of the test system. Here, unless the developing cells and proembryos are maintained in vitro in an environment of strict balance of nutritional and other factors, there is a chance (as in the case in over-enrichment) of massive proliferation of undifferentiated tissue being formed, or in the case of impoverishment, a great chance that proper growth or differentiation might not occur. Between the extremes lies the "optimum" set of gradients for the differentiation of tissues and organs to occur. In short, we feel the exaggerated potential for expression of plasticity of development and growth in in vitro systems, such as those involving totipotent free cells, should provide a valuable means to probe environmental and nutritional impacts as developmental expression responds to, and reflects, complex interactions such

as may be encountered in Space, and where precise developmental signals may be altered (cf. Jennings and Trewavas, 1986; Schlichting, 1986).

Cosmos Carrot Cell Culture Results Work done at Stony Brook in connection with Cosmos 782 and 1129 using totipotent carrot cells which could undergo somatic embryo formation showed that while the broad events of non-sexual embryogenesis could and did occur, problems remained. In the first instance, the carrot cell system we used for the Cosmos experiments involved the generation of so-called competent units, their induction on Earth so as to produce what are termed in botanical embryological parlance proembryos, and their subsequent exposure to Space conditions so as to evaluate their capacity to express further developmental capacity. The fine point of detail to be appreciated is that the cells used were already developmentally determined, and, by prior experience, shown to be capable of undergoing somatic embryogenesis. They were not manipulated to achieve their morphogenetic capability in Space. Since programmed cells, as it were, were generated on Earth, and chilled to preclude further development into embryos on Earth, we have argued that they could well have retained a "memory" of the Earth's g environment. How one might successfully "erase" such a "memory" is a moot point but it can be proposed that for a start, successive generations of morphogenetically undetermined plant cells should be grown and induced in Space in a micro g environment. The second criticism to be raised is that the Cosmos 782 experiment was not repeated on the Cosmos 1129 flight. A third is that none of the materials was fixed in flight. Only after satellite recovery and transport of samples to Moscow was fixation performed. Even now, only preliminary presentation has been made because of reluctance to publish inadequately repeated experiments (cf. Krikorian and Steward, 1978, 1979; Krikorian et al., 1981). For the purposes of making a point and in the context of this presentation, reference may be made to calculations carried out on data derived from 1 g centrifuge and micro g controls (cf. Tables 1 and 2). Here, the results of scoring the normalcy of the developmental pathway of competent cells and proembryonic units to later stages of embryogeny is presented. The transition from one embryonic stage to another was slowed down. Specifically, in micro g, a greater proportion of embryos were at "stage 2" and fewer embryos had progressed to "stages 3" or "4."

Theimer et al. (1986) using a system somewhat similar to carrot (they used anise, Pimpinella anisum) have reported increased biomass of embryonic structures generated in Space in liquid cultures. Most of the criticisms of experimental protocol raised above for our carrot experiments apply to their work with anise as well, however, and for me, their results remain arguable and equivocal as well. Surely much more work will be needed to resolve unanswered questions.

A much improved assay system for carrot is in the process of being developed at Stony Brook and will provide a much better opportunity to get definitive answers to questions as to whether development of cultured plant cells in Space can occur with acceptable fidelity from a morphological, cytogenetic and temporal perspective (cf. Smith and Krikorian, 1988). Not only will answers gotten from such systems be of interest to developmental plant biologists but they will have significance for those seeking to use biotechnological procedures and manipulations in Space for a variety of reasons (cf. Keefe and Krikorian, 1983). Indeed, the ability to use and manipulate cells and other kinds of propagules in vitro reliably in Space will be a necessary prerequisite to many projected or hypothesized commercialization schemes (cf. Krikorian, 1985).



Commentary. The foregoing seeks to emphasize therefore that there is much that we do not know about plant cells and how they behave in Space. Finally, and with no intention of detracting from the importance of studies seeking to obtain answers to such important questions as: To what extent does the gravitational environment influence polarity, axis determination and embryogenesis in vascular plants? Are the haphazard positions of the embryos and the abnormalities noted in megaspores grown on clinostats actually related to the effect(s) of g neutralization? Is the biochemical relationship between the embryo and nutrient supply - whether in situ in maternal tissue or in vitro in appropriately designed culture vessels or apparatuses designed to provide "all" the "right" signals - influenced by the Space environment? Also, the less sophisticated but perhaps more compelling questions arises as to whether we have satisfactory and convincing answers as to whether we yet have the means available to grow intact plants over protracted periods in Space. We have made some interesting observations on decreased levels of cell division in roots after they have grown for a week in Space, we have also observed chromosome aberrations such as fractures and breaks in cells of roots grown in Space for relatively short periods. There is much to suggest that we have a long way to go before we can be confident of being able to grow plants through successive generations (cf. Krikorian and O'Connor, 1984; Halstead and Dutcher, 1987). We have no reason to suppose that results of extended duration experimentation will not disclose or exaggerate responses such as those alluded to and that are merely suggestive and inconclusive at this time.

Acknowledgements. The research described in this presentation was supported from grants from the National Aeronautics and Space Administration. A broadly based research effort entitled "Cells, Embryos and Morphogenesis in Space," NASA NSG 7270 has permitted a range of aseptic test systems to be developed with the view of eventually exposing competent systems at varying levels of prior organization to the Space environment.

### References

- Barlow, P.W. and D.J. Carr, Eds. 1984. Positional Controls in Plant Development. Cambridge at the University Press. Cambridge and London.
- Brownlee, E. and J.W. Wood. 1986. A gradient of cytoplasmic free calcium in growing rhizoid cells of Fucus serratus. Nature (London) 320, 624-626.
- Halstead, T.W. and F.R. Dutcher. 1984. Status and prospects. pp. 3-18. In: Experiments on plants grown in space. Supplement 3. Annals of Botany 54.
- Halstead, T.W. and F.R. Dutcher. 1987. Plants in space. Annual Review of Plant Physiology. 38, 317-345.
- Ivanov, VI. 1974. [Problems of Space Biology, 27. Radiobiology and Genetics of Arabidopsis.] Problemy Kosmicheskoy Biologii, Tom. 27. Radiobiologiya i Genetika Arabidopsisa. pp. 1-191 Moscow. Nauka Press.
- Jennings, DH and A.J. Trewavas. 1986. Plasticity in Plants. Symposia of the Society for Experimental Biology. XL. Biochemical Society Book Depot, Colchester, U.K.

- Keefe, J.R. and A.D. Krikorian. 1983. Gravitational biology on the space station. SAE Technical Paper Series 831133. pp. 1-24. Thirteenth Intersociety Conference on Environmental Systems. San Francisco, California July 11-13, 1983. Society of Automatic Engineers, Warrendale, PA.
- LaMotte, C. 1937. Morphology and orientation of the embryo of Isoetes. *Annals of Botany N.S.* 1, 695-716.
- Krikorian, A.D. and S.A. O'Connor . 1984. Karyological observations. pp. 49-63. In: Experiments on plants grown in space. Supplement 3. *Annals of Botany* 54.
- Krikorian, A.D. and F.C. Steward. 1978. Morphogenetic responses of cultured totipotent cells of carrot (Daucus carota var. carota) at zero gravity. *Science*. 200, 67-68.
- Krikorian, A.D. and F.C. Steward 1979. Is gravity a morphological determinant at the cellular level? (COSPAR). *Life Sciences and Space Research* 17 (Ed. by R. Holmquist), PP. 271-284. Pergamon Press, Oxford and New York.
- Krikorian, A.D., F.R. Dutcher, C.E. Quinn and F.C. Steward. 1981. Growth and development of cultured carrot cells and embryos under spaceflight conditions. *Advances in Space Research* 1, 117-127.
- Krikorian, A.D., A.E. DeMaggio, P.B. Green, J.S. Heslop-Harrison and Y. Heslop-Harrison. 1984. Development and developmental genetics. pp. 42-48. In: *Plant Gravitational and Space Research. Report of a Workshop held April 30-May 2, 1984 in Rosslyn, Virginia.* Ed. by TW Halstead and TK Scott. *Workshop Summaries III.* American Society of Plant Physiologists, Rockville, Maryland.
- Krikorian, A.D. 1985. Concepts, strategies, and potentials using hypo-g and other features of the space environment for commercialization using higher plants. *The Physiologist* 28, No. 6. Suppl. S-179-180.
- Raghavan, V. 1986. *Embryogenesis in Angiosperms. A developmental and experimental study.* Cambridge, at the University Press. Cambridge and London.
- Schlichting, C.D. 1986. The evolution of phenotypic plasticity in plants. *Annual Review of Ecology and Systematics* 17, 667-693.
- Sinnott, E.W. *Plant Morphogenesis.* McGraw-Hill, New York.
- Smith, D.L. and A.D. Krikorian. 1988. Production of somatic embryos from carrot tissues in hormone-free medium. *Plant Science* 58, 103-110.
- Theimer, R.R., R.A. Kudielka and I. Rösch. 1986. Induction of somatic embryogenesis in Anise in microgravity. *Naturwissenschaften* 73, 442-443.

- Warlaw, C.W. 1955. Embryogenesis in Plants. John Wiley, New York.
- Wardlaw, C.W. 1965a. General physiological problems of embryogenesis in plants. pp. 424-451. In: Encyclopedia of Plant Physiology, vol XV/I. Springer Verlag, Berlin.
- Wardlaw, C.W. 1965b. Physiology of embryonic development in cormophytes. pp. 844-965. In: Encyclopedia of Plant Physiology, vol. XV/I, Springer Verlag, Berlin.
- Willemse, M.T.M. 1981. Polarity during megasporogenesis and megagametogenesis. Phytomorphology 31, 124-134.

Table 1

Contingency Chi-square Method of Analysis for Somatic Embryogenesis in microgravity and on a 1 g centrifuge in Space. Stages of embryo development were subjectively categorized as Stages 1 to 4. Analysis from data of Krikorian and Steward (1978).

		0 g	1 g	Σ	% of Total
Stage 1 (Heart Shaped)	Obs.	6105	5655	11760	67.70
	Exp.	6103.16	5656.34	11759.5	
	Dev.	+ 1.84	- 1.34		
	$\chi^2$	0.0006	0.0003	0.0009	
Stage 2 (Torpedo shaped, <.75 and 1.5 mm long)	Obs.	1680	1345	3025	17.42
	Exp.	1570.41	1455.44	3025.85	
	Dev.	+109.59	- 110.44		
	$\chi^2$	7.65	8.38	16.03	
Stage 3 (Advanced embryonic forms with distinct root between .75 and 1.5 mm long)	Obs.	760	865	1625	9.36
	Exp.	843.80	782.02	1625.83	
	Dev.	- 83.80	+82.97		
	$\chi^2$	8.32	8.80	17.12	
Stage 4 (small plantlets with well devel- oped root, > 1.5 mm)	Obs.	470	490	960	5.53
	Exp.	498.53	462.03	960.56	
	Dev.	- 28.53	+27.97		
	$\chi^2$	1.63	1.69	3.32	
Σ	Obs.	9015	8355	17370	100.01
	Exp.	9015.90	8355.84	17371.74	
	Dev.	- 0.90	-0.84		
	$\chi^2$	17.60	18.87	36.47	
	% of total	51.90	48.10		
Chi-square $\chi^2 = \sum(\text{Obs}-\text{Exp})^2 = 36.47$					
Degrees of freedom = (2-1)/Exp (4-1) = 3					
p< .001					
Table $\chi^2$ (df3, P.001) = 16.27					
Method of calculating expected values					
Exp (Stage 1, 0g) = (% of total for Stage 1) (Total in 0 g)					
= (.6670) (9015) = 6103.16 etc.					

Table 2

Comparison of degrees of embryonic development (stages 1 to 4) achieved by totipotent cells of carrot at 0 g and 1 g. Since the total number of plants at 0 g (9015) and 1 g (8355) were unequal, use was made of a contingency chi-square test. Analysis from data of Krikorian and Steward (1978).

OBSERVED (PERCENT OF TOTAL)

	0 g	1 g	Difference
Stage 1 (Heart shaped)	67.7	67.7	0
Stage 2 (Torpedo shaped < .75 mm long)	18.6*	16.1	+2.5
Stage 3 (advanced embryonic forms with distinct root between .75 and 1.5 mm long)	8.4	10.4	-2.0
Stage 4 (small plantlets, with well developed root, > 1.5 mm)	5.2	5.9	-0.7
$\Sigma$	99.9	100.1	

\*At 0 g, a greater proportion of plants were still at stage 2, and fewer plants had progressed to stages 3 or 4.  $P < .001!$

THE SENSORY TRANSDUCTION PATHWAYS  
IN BACTERIAL CHEMOTAXIS

Barry L. Taylor  
Department of Microbiology,  
School of Medicine,  
Loma Linda University  
Loma Linda, California 92350

Bacterial chemotaxis is the least complex behavioral response and will probably be the first behavioral system in which the entire sensory transduction pathway from stimulus to response can be described in terms of a sequence of biochemical and physical events. As such, it is a useful model for understanding how more complex cells and organisms respond to changes in their surroundings. Chemotaxis is the name given to the movement of motile bacteria toward a source of nutrients and away from harmful substances, thereby enhancing their chances of survival. Bacteria also respond to a variety of other sensory stimuli (Koshland, 1988; Macnab, 1987b; Taylor, 1983a).

Escherichia coli and Salmonella typhimurium, the bacteria most commonly investigated, swim by rotating four to nine flagella per cell. The flagellar filament, which is composed of a single type of protein, is like a flexible corkscrew with a left-handed helix (Macnab, 1987a). The flagellar motor is embedded in the plasma membrane and anchored to the peptidoglycan and outer membrane. The rod, which is the shaft of the motor, is connected to the filament by a universal joint known as the hook.

If the flagellar motors rotate in a counterclockwise direction, hydrodynamic forces collect the flagella into a bundle which has a synchronized wave propagation that propels the bacterium forward (Macnab, 1987b). When the motors briefly reverse and rotate the flagella in a clockwise direction, the flagella bundle flies apart causing a chaotic tumbling motion that reorients the bacterium. When counterclockwise rotation is resumed, the bacterium swims off in a different direction. The net result of the random alternation between counterclockwise and clockwise rotation is a random walk type of motion (Berg and Brown, 1972).

A temporal sensing mechanism is utilized by the bacteria to continuously sample attractants and repellents in the environment and to compare the present environment with the environment that the bacterium has just left (Macnab and Koshland, 1972). If the difference is favorable, tumbling is suppressed and the bacterium continues in the favorable direction. If the difference is unfavorable, the probability of tumbling increases thereby ensuring that the bacterium will change direction. The net effect is to bias the random walk motility so that the bacteria migrate to a favorable environment. A central goal of research into chemotaxis is to determine the pathway by which external stimuli modulate the probability of clockwise rotation of the flagellar motors.

The strongest attractants for E. coli and S. typhimurium are the amino acids serine and aspartate (Macnab, 1987b). Other chemical attractants include some of the other amino acids, sugars and sugar alcohols. Chemical repellents include short-chain fatty acids and alcohols, some hydrophobic amino acids, indole, benzoate, sodium sulfide and the divalent cations  $\text{Co}^{2+}$  and  $\text{Ni}^{2+}$ . Other

tactic stimuli include oxygen, temperature, pH and osmotic strength. Many species of phototrophic bacteria are phototactic.

The methylation-dependent pathways for bacterial chemotaxis are represented in Figure 1. Chemoattractants either bind directly to a specific membrane-spanning transducing protein or activate a soluble binding protein that subsequently binds to a transducing protein (Koshland, 1988; Macnab, 1987b). No specific receptors for repellents have been unequivocally identified; repellents may act by perturbing the membrane domain that surrounds the transducing protein. The four transducing proteins in *E. coli* that have been identified are the products of the *tsr*, *tar*, *trg* and *trp* genes. Each consists of a periplasmic domain, two membrane-spanning sequences and a cytoplasmic domain (Koshland, 1988; Krikos et al, 1983).

There is a high degree of sequence identity in the cytoplasmic domains of the four transducing proteins (Krikos et al, 1983). Two conserved regions contain the sites that are methylated during adaptation (see below). Another highly conserved region is believed to be involved in transmitting chemotactic signals to the flagellar motors. This assignment is made on the basis of signaling-deficient bacteria that have mutations in the conserved region. Specificity is conferred on the transducing proteins by the variable binding domains in the periplasmic portion of the protein. This has been verified using chimeric constructs of the *tsr* and *tar* genes that consist of a 5' region coding for the N terminus of one transducing protein and the 3' region coding for the C terminus of the other transducing protein (Krikos et al, 1985). Receptor specificity of the chimeric protein is similar to that of the Tsr or Tar transducer that has the same N terminus.

Until recently little progress had been made in identifying the post-transducer events in signal transduction. The application of three experimental strategies has now revealed at least the skeleton of the transduction pathway. A novel method for depleting *S. typhimurium* of ATP was used by Junichi Shioi in my laboratory to demonstrate a requirement for ATP in chemotaxis (Shioi et al, 1982). So called "guttled" strains of *E. coli* that were depleted of chemotaxis genes but had normal flagellar motors were used to study the effect on chemotaxis of restoring a single chemotaxis gene or a combination of genes to the guttled strain (Wolfe et al, 1987). A comparison of the sequence of three chemotaxis genes, *cheA*, *cheY* and *cheB*, with gene sequences available in gene banks revealed a striking similarity with the structural genes for a family of bacterial regulatory proteins (Stock, 1987). The *ntrB* and *ntrC* genes involved in nitrogen assimilation in *E. coli* are the most studied members of this family.

In the guttled strain the motor rotates only in a counterclockwise direction (Parkinson and Houts, 1982). Investigations in the laboratory of Daniel Koshland, Jr. demonstrated that introduction of the *CheY* protein restored clockwise rotation (Clegg and Koshland, 1984). The probability of clockwise rotation was a hyperbolic function of the concentration of *CheY* indicating that the binding of *CheY* to the switch was the signal for clockwise rotation (Kuo and Koshland, 1987). Subsequent studies in our laboratory established that an active form of *CheY* causes clockwise rotation and ATP is essential to activate *CheY* (Smith et al, 1988). This and the similarity of the Che and Ntr regulatory proteins suggested that the *CheY* protein was activated by phosphorylation of the protein.

Wolfe, Conley, Kramer and Berg (1987) discovered that the minimal additions to the guttled strain required for a chemotaxis signal from the Tar

transducing protein to reach the motor were the cheA, cheW and cheY genes. Hess, Oosawa, Matsumura and Simon (1987) found that the CheA protein is autophosphorylated in vitro by ATP and then transfers the phosphate moiety to the CheY protein. It is assumed, but not yet proven, that in vivo the transducing proteins control either the phosphorylation of CheA or the transfer of phosphate from CheA to CheY.

In addition to responding to chemotactic stimuli, bacteria adapt to such stimuli. This was first demonstrated when Macnab and Koshland (1972) used a rapid-mixing device to add attractant to a culture of S. typhimurium. The cells suppressed all tumbling and swam smoothly for a short interval, then adapted to the attractant and returned to a random motility pattern. At the molecular level, adaptation to an attractant occurs when the transducing protein is multiply methylated by a protein methyltransferase that is the product of the cheR gene (Springer et al, 1979; Springer and Koshland, 1977). The methyl donor in this reaction is S-adenosylmethionine. Methylation precisely cancels the signal generated by the attractant. If the attractant is subsequently removed or if a repellent is added, the cells tumble continuously then adapt when some of the methyl esters on the transducing proteins are hydrolyzed by the esterase activity of the cheB gene product (Stock and Koshland, 1978).

The methylation-dependent pathways are the major chemotactic pathways and are utilized in responding to most stimuli. However, Mitsuru Niwano working in my laboratory discovered that adaptation to oxygen and to most sugars is independent of transducer methylation (Niwano and Taylor, 1982). The major focus of our research has been these methylation-independent pathways.

The attraction of E. coli or S. typhimurium to oxygen is readily observed in the accumulation of these bacteria around a trapped air bubble in a drop of culture beneath a cover slip (Taylor, 1983a). Some other species behave differently in the presence of a gradient of oxygen. Beijerinck (1893) observed in the last century that aerobic bacteria beneath a coverglass form a band near the air-liquid interface. Microaerophilic bacteria accumulate in a band that is some distance from the interface and anaerobic bacteria accumulate in the center of the cover slip. This suggests that oxygen is both an attractant and a repellent and that bacteria migrate to where the oxygen concentration is optimal for their metabolic lifestyle (Taylor, 1983a,b). This is not surprising in view of the toxicity of some oxygen derivatives.

To distinguish between the responses of enteric bacteria to high ( $K_{0.5} = 1.0$  mM) and low ( $K_{0.5} = 0.7 \mu\text{M}$ ) concentrations of oxygen, the responses will be referred to as the oxygen repellent and oxygen attractant responses, respectively (Laszlo et al, 1984; Shioi et al, 1987). We found that the attractant response to oxygen is mediated by the proton motive force (Laszlo and Taylor, 1981; Shioi and Taylor, 1984). Oxygen binding to the terminal oxidase of the respiratory chain increases the rate of electron transport which is coupled to translocation of protons across the inner membrane. E. coli and S. typhimurium sense and respond to changes in the proton motive force. This is also the basis of the phototactic response in photosynthetic bacteria (Harayama and Iino, 1977). We have shown that tactic responses result from a wide variety of phenomenon that perturb the proton motive force (Taylor, 1983a,b).

Ongoing studies in our laboratory are looking at the convergence of the methylation-dependent and methylation-independent pathways for chemotaxis. The gutted strain of E. coli with a functional flagellar motor did



not respond to oxygen or to the sugar mannose which acts via the phosphotransferase system, another methylation-independent pathway (Rowell et al, 1988; Taylor et al, 1988). The addition of various chemotaxis genes showed that a normal response to oxygen or mannose was not observed unless the cheA, cheW and cheY genes were present. This indicates that the methylation-independent and methylation-dependent pathways converge at or before the cheA protein. It remains to be determined how the methylation-independent pathways modulate the phosphorylation of the cheY protein.

- Beijerinck, M. W. 1893. Ueber Atmungsfiguren beweglicher Bakterien. Z. Bakteriologie, Parasitenkunde, Infektionskrankheiten, Hygiene, Abteilung I, Originalien, 14:827-845.
- Berg, H. C., and D. A. Brown. 1972. Chemotaxis in Escherichia coli analysed by three-dimensional tracking. Nature (London) 239:500-504.
- Clegg, D. O., and D. E. Koshland, Jr. 1984. The role of a signaling protein in bacterial sensing: behavioral effects of increased gene expression. Proc. Natl. Acad. Sci. USA 81:5056-5060.
- Harayama, S., and T. Iino. 1977. Phototaxis and membrane potential in the photosynthetic bacterium Rhodospirillum rubrum. J. Bacteriol. 131:34-41.
- Hess, J. F., K. Oosawa, P. Matsumura, and M. I. Simon. 1987. Protein phosphorylation is involved in bacterial chemotaxis. Proc. Natl. Acad. Sci. USA 84:7609-7613.
- Koshland, D. E., Jr. 1988. Chemotaxis as a model second-messenger system. Biochemistry 27:5829-5834.
- Krikos, A., M. P. Conley, A. Boyd, H. C. Berg, and M. I. Simon. 1985. Chimeric chemosensory transducers of Escherichia coli. Proc. Natl. Acad. Sci. USA 82:1326-1330.
- Krikos, A., N. Mutoh, A. Boyd, and M. I. Simon. 1983. Sensory transducers of E. coli are composed of discrete structural and functional domains. Cell 33:615-622.
- Kuo, S. C., and D. E. Koshland, Jr. 1987. Roles of cheY and cheZ gene products in controlling flagellar rotation in bacterial chemotaxis of Escherichia coli. J. Bacteriol. 169:1307-1314.
- Laszlo, D. J., B. L. Fandrich, A. Sivaram, B. Chance, and B. L. Taylor. 1984. Cytochrome o as a terminal oxidase and receptor for aerotaxis in Salmonella typhimurium. J. Bacteriol. 159:663-667.
- Laszlo, D. J., and B. L. Taylor. 1981. Aerotaxis in Salmonella typhimurium: role of electron transport. J. Bacteriol. 145:990-1001.
- Macnab, R. M. 1987a. Flagella, p. 70-83. In F. C. Neidhardt, J. L. Ingraham, K. B. Low, B. Magasanik, M. Schaechter, and H. E. Umbarger (ed.), Escherichia coli and Salmonella typhimurium. American Society for Microbiology, Washington, D. C.
- Macnab, R. M. 1987b. Motility and chemotaxis, p. 732-759. In F. C. Neidhardt, J. L. Ingraham, K. B. Low, B. Magasanik, M. Schaechter, and H. E. Umbarger (ed.), Escherichia coli and Salmonella typhimurium. American Society for Microbiology, Washington, D. C.
- Macnab, R. M., and D. E. Koshland, Jr. 1972. The gradient-sensing mechanism in bacterial chemotaxis. Proc. Natl. Acad. Sci. USA 69:2509-2512.
- Niwano, M., and B. L. Taylor. 1982. Novel sensory adaptation mechanism in bacterial chemotaxis to oxygen and phosphotransferase substrates. Proc. Natl. Acad. Sci. USA 79:11-15.

- Parkinson, J. S., and S. E. Houts. 1982. Isolation and behavior of Escherichia coli deletion mutants lacking chemotaxis functions. *J. Bacteriol.* 151:106-113.
- Rowell, E. H., J. M. Smith, A. J. Wolfe, M. P. Conley, B. L. Taylor, and H. C. Berg. 1988. Convergence of the methylation-dependent and methylation-independent pathways for bacterial chemotaxis. *FASEB J.* 2:A575.
- Taylor, B. L. 1983a. Role of proton motive force in sensory transduction in bacteria. *Ann. Rev. Microbiol.* 37:551-573.
- Taylor, B. L. 1983b. How do bacteria find the optimal concentration of oxygen? *Trends Biochem. Sci.* 8:438-441.
- Taylor, B. L., M. S. Johnson, and J. M. Smith. 1988. Signaling pathways in bacterial chemotaxis. *Botanica Acta* 101:101-104.
- Shioi, J., C. V. Dang, and B. L. Taylor. 1987. Oxygen as attractant and repellent in bacterial chemotaxis. *J. Bacteriol.* 169:3118-3123.
- Shioi, J., R. J. Galloway, M. Niwano, R. E. Chinnock, and B. L. Taylor. 1982. Requirement of ATP in bacterial chemotaxis. *J. Biol. Chem.* 257:7969-7975.
- Shioi, J., and B. L. Taylor. 1984. Oxygen taxis and proton motive force in Salmonella typhimurium. *J. Biol. Chem.* 259:10983-10988.
- Smith, J. M., E. H. Rowell, J. Shioi, and B. L. Taylor. 1988. Identification of a site of ATP requirement for signal processing in bacterial chemotaxis. *J. Bacteriol.* 170:2698-2704.
- Springer, M. S., M. F. Goy, and J. Adler. 1979. Protein methylation in behavioural control mechanisms and in signal transduction. *Nature (Lond.)* 280:279-284.
- Springer, W. R., and D. E. Koshland, Jr. 1977. Identification of a protein methyltransferase as the cheR gene product in the bacterial sensing system. *Proc. Natl. Acad. Sci. USA* 74:533-537.
- Stock, J. 1987. Mechanisms of receptor function and the molecular biology of information processing in bacteria. *BioEssays* 6:199-203.
- Stock, J. B., and D. E. Koshland, Jr. 1978. A protein methyltransferase involved in bacterial sensing. *Proc. Natl. Acad. Sci. USA* 75:3659-3663.
- Wolfe, A. J., M. P. Conley, T. J. Kramer, and H. C. Berg. 1987. Reconstitution of signaling in bacterial chemotaxis. *J. Bacteriol.* 169:1878-1885.

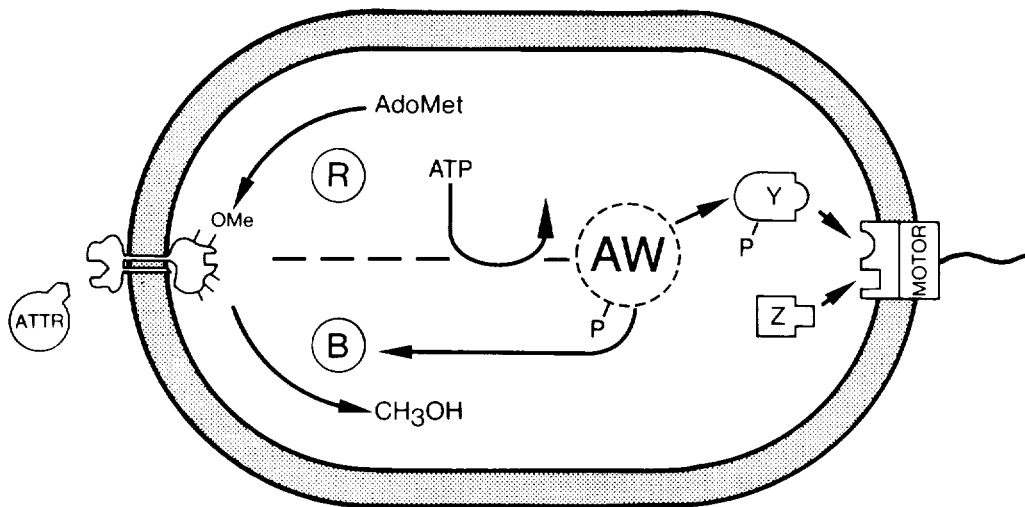

Figure 1. Scheme for sensory transduction in methylation-dependent chemotaxis in *E. coli* and *S. typhimurium*. R, B, A, W, Y and Z represent the product of the *che* genes with the same letter designation. Attr, attractant; AdoMet,  $\text{S}$ -adenosylmethionine; OMe,  $\gamma$ -glutamyl carboxymethyl ester; ---> order of reactions is tentative.

## PHYSICAL PHENOMENA AND THE MICROGRAVITY RESPONSE

Paul Todd  
National Institute of Standards and Technology  
Chemical Engineering Science Division  
325 Broadway  
Boulder, CO 80303

## INTRODUCTION

Whenever we have pursued simple physical descriptions of the inner workings of the cell we have discovered that nature was there long ago, genetically programming high-precision macromolecular machinery to assure the eternal persistence of a particular physical process, such as maintenance of the internal electrolytes of the cell by a collection of gates and pumps, maintenance of cell shape with not one or two, but at least three whole systems of cytoskeletal proteins, assuring the immortality of the genome itself through a complex system of repair enzymes we have barely begun to understand, etc. Very little about the cell is left to chance. But nature has never been given the opportunity to consider the maintenance of the living cell in the absence of net inertial acceleration and its consequences, such as hydrostatic pressure, buoyant flow, and sedimentation.

At the inception of space research some 30 years ago, there was concern in the U.S. and the Soviet Union about the effects of weightlessness on living things. It needed to be known in particular whether the absence of gravity had no effect or a catastrophic effect on biological systems under space flight conditions. It was easy to solve problems introduced by the space environment by the use of engineering to protect against the lack of an atmosphere and the presence of radiation, but engineering against weightlessness and its possible biological effects proved to be extremely difficult. Fortunately, early experiments indicated that the biological effects of low gravity were certainly not catastrophic, and the 84-day Skylab mission and substantially longer Soviet missions succeeded in the absence of a gravitational field. However, profound physiological changes were noted, and countermeasures are in use in modern manned space flights.

Current and future research is directed at the basic study of what we presume to be gravity dependent environmental responses. In other words, space flight conditions are being made available for basic science experiments.

Although we know of many biological phenomena affected by gravity, their connection to molecular and physical processes are poorly understood. In this sense, the effect of gravity is paradoxical because the cell is the basic structure of living things, and the organisms' properties depend upon cells. Yet it is much easier to think of gravity as acting on larger systems as cells are at the limit of size and mass which is influenced by the gravitational field in the presence of thermal motion.

Since the beginning of the orbital space flight era in 1957, scientific experiments on the effects of weightlessness on cells from all five living kingdoms have been performed (Edwards, 1969; Moskvitin & Vaulina, 1975; Saunders, 1971; Taylor, 1977; Young and Tremor, 1968 a,b). Opportunities to perform, let alone repeat, experiments in the microgravity environment of orbital space flight have been rare. Until recently there has been a tendency

to generalize on the basis of a small number of unrepeated experiments. Early negative results (Montgomery et al., 1974) that tended to confirm negative predictions (Pollard, 1965) were at one time in danger of becoming dogma. The field of microgravity cell biology has suffered, not only from a paucity of reproducible data but from a constrained research paradigm in which an inadequate variety of physical phenomena has served as a resource for hypothesis testing.

It is the purpose of this article to review a broad range of gravity-dependent physical processes, including interactions among these processes and to indicate how they might apply at the dimensions of single cells.

But first, a few definitions may help guide investigations of gravitational effects at the single-cell level. While all cells on earth evolved in the presence of a 1-g field, some developed mechanisms to use this field (root and shoot gravitropism) while others developed countermeasures against its effect (muscle, cytoskeleton). The unnatural unloading of this force affects essential mechanism in the former case and fortuitous ones in the latter. Correspondingly, the former type of cell (plant, protozoa) responds to gravity, while the latter (animal) is affected by gravity. It is now possible to consider inertial acceleration as a continuous variable - all the way down to almost zero ( $10^{-6}$  -  $10^{-4}$  x g), so while zero may be considered the origin of g as with any variable, the baseline value is  $g = 1$  (or  $9.8 \text{ m/sec}^2$ ). This somewhat inverted situation tempts one to study "the effect of microgravity" rather than to "perform g-unloading experiments."

#### A CORNUCOPIA OF GRAVITY-RELATED PHYSICAL PROCESSES

Inertial accelerations, including gravity, play a role in directly affecting the motion of masses and by contributing to motion when other forces are present. A few examples that apply to small particles and fluids are introduced.

##### 1. Sedimentation

Stokes' sedimentation describes the constant velocity of a particle falling through a fluid, in which gravitational, buoyant, and viscous drag forces are balanced. Beginning with

$$F(\text{grav}) - F(\text{buoy}) - F(\text{drag}) = 0 \quad (1)$$

one finds for a sphere of radius  $a$  and density  $\rho$  that the "terminal velocity" is

$$v = 2(\rho - \rho_0) a^2 g / 9 \eta \quad (2)$$

where  $\rho_0$  is the fluid density, and  $\eta$  is the fluid viscosity. It can be seen from equation (2) that sedimentation rate depends in a sensitive way on particle radius (squared) and density (from which fluid density is subtracted.)

## 2. Diffusion/Brownian motion

Einstein succeeded in describing diffusion as the consequence of a "random walk" executed by particles due to their thermal energy  $kT$  ( $k$ =Boltzmann's constant). The surprisingly simple result was

$$\langle x^2 \rangle = 2 D t \quad (3)$$

where  $\langle x^2 \rangle$  = mean square distance travelled by a particle having diffusion coefficient  $D$  in time  $t$ .  $D$  can be derived from the thermal energy  $kT$  of a particle of radius  $a$  undergoing Brownian movement in a fluid with viscosity  $\eta$  :

$$D = k T / 4 \pi \eta a \quad (4)$$

These relationships give rise to Fick's laws of diffusion, in which the net unidirectional flux of particles is proportional to the gradient,  $dc/dx$ , of the particle concentration  $c$ .

Diffusion is not affected by gravity and occurs in its absence. However, diffusion and sedimentation velocities are sometimes similar, and their sum results in gradual settling; and under certain combinations of  $D$ ,  $\eta$ , and  $dc/dx$ , the collective behavior of dissolved molecules and/or particles results in droplet (or zone) sedimentation.

## 3. Isothermal settling

If the temperature  $T$  does not change substantially over the height  $h$  of an ensemble of particles, then the mean kinetic energy  $kT$  of all particles is the same at all heights. The potential energy of a particle of mass  $m$  is usually expressed as  $mgh$ , but if the particles are subject to buoyancy in the fluid the potential energy becomes  $V (\rho - \rho_0)gh$ , if the particle volume is  $V$ . From the famous Boltzmann distribution rule the concentration of particles at height  $h$  will be established:

$$c(h) = c(0) \exp [-V(\rho - \rho_0) g h/kT]. \quad (5)$$

This means concentration is an exponential function of height under isothermal conditions and that large, dense particles with P.E.  $\gg kT$  (from mammalian cells to marbles) will be concentrated at  $h = 0$  and that small particles, such as certain organelles have values of  $V$  and  $\rho$  that lead to exponential distributions of  $c(h)$  (Pollard, 1965).

## 4. Droplet sedimentation

The diffusion coefficients of small molecules are in the range of  $10^{-6}$  to  $10^{-5}$   $\text{cm}^2/\text{sec}$ , of macromolecules  $10^{-7}$  to  $10^{-6}$ , and of whole cells and particles  $10^{-12}$  to  $10^{-9}$ . If a small zone, or droplet, of radius  $R$  contains  $n$  particles of radius  $a$  inside, whose diffusivity is much less than that of particles outside, then rapid diffusion of solutes in and slow diffusion of particles out of the droplet leads to a transient locally increased density of the droplet:

$$\rho_D = \rho_0 + \frac{a^3}{R^3} \eta (\rho - \rho_0). \quad (7)$$

If  $\rho_D > \rho_0$  then the droplet falls down; if  $\rho_D < \rho_0$  it is buoyed upward - the so-called Rayleigh-Taylor instability condition. Droplet sedimentation (or buoyancy) is a special case of a more general phenomenon—convection.

### 5. Convection

The sedimentation or buoyancy of fluid zones (large or small) often occurs due to thermal (temperature) gradients that cause lower zones to become less dense than zones above them. In a sense, motion of the type described by equation (2) follows, but, depending on the values of dimensionless ratios (Rayleigh number, Grasshof number), this motion can be spatially patterned (Bénard cells). In addition to thermal convection, solutal convection can occur when concentration gradients lead to dense solutions being found above less-dense solutions, even under isothermal conditions. Owing to the lack of good quantification of convection at small dimensions, we do not know whether or not convection inside a single cell is possible. It is quite apparent, however, that convective forces play a role in early post-nucleation events during the growth of crystals from solution (Kam et al., 1978).

### 6. Particle streaming

When solid particles or droplets of two densities are present, and when one particle type sediments downward while the other is buoyed upward, a traffic pattern is established whereby fine streams of alternating upward and downward fluid motion occur. Batchelor (1986) characterized this motion on the basis of a follow-the-leader paradigm which seems to be broadly applicable and represents yet another example of collective behavior of particles suspended in a fluid.

### 7. Flocculation and coalescence

Flocculation is the attachment of suspended particles or molecules to one another when Van der Waals interactions are not counteracted by electrostatic repulsion (colloid instability). Coalescence is the growth of liquid droplets or films within or on another immiscible liquid. These two chemically different phenomena have the same hydrodynamic outcome: the value of  $a^2$  in equation (2) increases, thereby increasing  $v$ . Gravity often causes these phenomena to be non-linear, as the increase in  $a^2$  increases the collision cross-section, thereby further enhancing the flocculation and coalescence phenomena. While coalescence is due to interfacial (surface) tension, flocculation is related to electrokinetic properties of molecules or particles. These two phenomena are independent of gravity and occur in its absence (Van Alstine et al., 1987); however, inertial unloading can profoundly affect the ability of these forces to act, and the rate at which they proceed.

## 8. Interfacial, or surface, tension

Surface tension is the force per unit length required to maintain a surface or an interface between 2 phases. Surface free energies for most liquids are  $\gg kT$ ; when they are not "superfluidity" occurs. Although the cell's plasma membrane is composed primarily of lipid, the presence of transmembrane protein reduces its surface tension to less than 1% that of an oil-water interface (Davson-Danielli, 1951). Low-gravity research has provided a number of insights into interfacial behavior (Subramanian, 1986) because large drops and bubbles can be formed and manipulated. The water filling an entire drinking glass, for example, can, and does, form a perfect sphere. Do round cells sag on earth, and do flat cells become round in space flight (Pollard, 1974)? Certain animal eggs can be shown to "sag" when resting on a surface at specific stages; on the other hand all single-cell types studied in space to date have been makers of their own destiny. Their shapes have been determined by their cytoskeleton, the forces of which substantially exceed inertial and surface forces. Not all cell types are the same, however, and the polymerization bonds that shape the cell are weaker in some cell types than they are in others.

## 9. Particle electrokinetics

The surface charge density of suspended particles prevents their coagulation and leads to stability of lyophobic colloids. This stability is the backbone of such huge enterprises as paints and coatings, pulp and paper, sewage and fermentation, etc. The same charges, of course, lead to motion when such particles are suspended in an electric field. The particle surface has an electrokinetic ("zeta") potential,  $\zeta$ , proportional to  $\sigma_e$ , its surface charge density - a few mV on stable particles, including cells in aqueous suspension. If the solution has dielectric constant  $\epsilon$ , the electrophoretic velocity is

$$v = \frac{\zeta \epsilon}{6 \pi \eta} E \quad (8)$$

for small particles, such as molecules, whose radius of curvature is similar to that of a dissolved ion ("Debye-Hückel particles), and

$$v = \frac{\zeta \epsilon}{4 \pi \eta} E \quad (9)$$

for large ("Smoluchowski") particles, such as cells and organelles in an electric field,  $E$ .

## 10. Streaming potential

If a charged particle moves an electrical potential will be created, and this potential will impart motion to other charges in the environment, including dissolved ions. While the  $\zeta$  potential of a stationary particle is only "felt" by



charges up to 7 Å or so away, an electric field spreads over greater distances when the particle moves. If a particle is caused to move by the acceleration of gravity (upward or downward) the strength (V/cm) of the electric field generated is

$$E = \frac{\zeta \epsilon (\rho - \rho_0) g}{3 \pi \eta \kappa} \quad (10)$$

where  $\kappa$  is the Debye-Hückel constant, measured in  $\text{cm}^{-1}$  and is directly proportional to the ionic strength of the surrounding medium. The force of this field is counter to the direction of motion of the particle, hence the name "counter streaming potential" also known as the "Dorn Effect." This potential could be as great as 20 mV.

### 11. Interacting fields

In reality, no force acts in the absence of other forces, and to some degree, from zero on upward, forces affect each other's actions. To deal with this fact, all types of flow (mass, charge, magnetic flux, etc.) are assumed to be non-independent, and transport relationships are described by a flow-and-field matrix. All flows  $J$  are caused by a field, generalized as  $\Delta\mu$ , in proportion to a coefficient  $L$  that relates them:

$$J = L \Delta\mu \quad (11)$$

For example,  $J$  might be the movement of mass falling through a specified area ( $\text{kg m}^{-2} \text{sec}^{-1}$ ),  $\Delta\mu$  would then be the inertial force field, in this case the acceleration of gravity,  $g$  over time  $\Delta t$ .  $L$  will convert the inertial coefficient (mass, in the simplest case) and the amount of material falling (concentration), or

$$J_m = N m g \Delta t \quad (12)$$

also familiar as Newton's 2nd law. Flow can be generalized on the basis of what is flowing,  $J_i$ , and the fields causing the flow,  $\Delta\mu_j$ ; more than one type of field can cause more than one type of flow, so in general one has a matrix type of field:

$$J_1 = L_{11} \Delta\mu_1 + L_{12} \Delta\mu_2 + L_{13} \Delta\mu_3 \cdots$$

$$J_2 = L_{21} \Delta\mu_1 + L_{22} \Delta\mu_2 + L_{23} \Delta\mu_3 \cdots$$

$$J_3 = L_{31} \Delta\mu_1 + L_{32} \Delta\mu_2 + L_{33} \Delta\mu_3 \cdots$$

$$\text{or } J_i = \sum_j L_{ij} \Delta\mu_j \quad (13)$$

This means, for example, electric fields can move charged masses and gravitational fields can move charges associated with mass. In this example (a falling charged particle) one can determine the downward mass flux,  $J_m$ , and the electric current  $I = J_e$ :

$$J_m = L_{11} \Delta\mu_g + L_{12} \Delta\mu_e \quad (14a)$$

$$J_e = L_{21} \Delta\mu_g + L_{22} \Delta\mu_e \quad (14b)$$

In most cases,  $L_{21}$  and  $L_{12}$ , the cross-term coefficients (the effect of gravity on a current and the effect of the electric field on sedimentation, respectively) are considered small compared to  $L_{11}$  and  $L_{22}$ . However, most physicists will point out that, at subcellular dimensions  $\Delta\mu_e \gg \Delta\mu_g$ , so it may not be possible to ignore cross terms in subcellular transport. In any case, solution of equations (14) at equilibrium leads to (Tobias et al., 1972):

$$J_m = \frac{8 \Pi a^3 (\rho - \rho_0)^2 c g}{27 \eta} + \frac{\zeta \epsilon a^3 (\rho - \rho_0) c E}{3 \eta} \quad (15a)$$

$$J_e = \frac{\zeta \epsilon a^3 (\rho - \rho_0) g c}{3 \eta} + k E \quad (15b)$$

where  $k$  = specific conductivity and  $c$  = concentration. Each of these terms is recognizable, from the top, left to right, as Stokes sedimentation (equation (2)), Dorn-effect electrophoresis (equations (9) and (10)), streaming potential (equation (10)), and Ohm's law.

## 12. Work

Whole cells, and presumably their parts, are ultimately positioned vertically with respect to one another or some marker. In most cases, this means that each positioned object gained the potential energy associated with its vertical position  $h$ , above the place where it was born, by the performance of net work  $W$ , which is path-independent:

$$W = V (\rho - \rho_0) g h \quad (16)$$

## SOME APPLICATIONS TO THE CELL

Phenomena to which the above-mentioned principles apply can be identified inside every cell and among cells. A few examples are considered here.

### 1. Sedimentation, Eukaryotic chromosome example

If the metaphase eukaryotic chromosome is considered as a compact object, as indicated in Figure 1, its sedimentation velocity can be estimated to be

around  $2 \times 10^{-7}$  cm/s -- similar to its rate of poleward migration during anaphase (Todd, 1977).

## 2. Sedimentation of organelles

If the same treatment is applied to selected organelles (those sufficiently large and dense to be worthy of consideration (Pollard, 1965; Fawcett, 1966; Tobias et al, 1972)), the approximate physical properties of each, given in Table 2, can be used to estimate the sedimentation velocities of each, also listed in Table 2. The final column in Table 2 indicates caution. Most of these organelles are anchored in place by cytoskeletal structures (in the case of chromosomes and the nucleus (Prescott et al., 1972; McNutt et al., 1973)) or embedded in internal membranes (in the case of mitochondria, plastids, and dictyosomes (Shen-Miller, 1972 a,b,c,d)), or both - see Table 3. Only the motions of otoliths and amyloplasts (statoliths) are known to be responsive to g and responsible for a measurable g-response (Audus, 1962, 1964; Gray and Edwards, 1971).

## 3. Isothermal settling of platelets

Human platelets stored in microgravity have a longer lifetime than their counterparts on the ground (Surgenor, 1987). Interactions that occur during settling are among the hypothetical causes of the short life span of the thrombocyte in vitro. While a certain amount of flocculation occurs during platelet storage, it is nevertheless reasonable to ask whether single-platelet suspensions actually settle. First, a Stokes' sedimentation velocity can be estimated as  $0.01 \mu\text{m/s}$  (Table 4), which corresponds to about 1 diameter settling distance every five minutes. Brownian movement will lead to a final vertical distribution given by equation (5) in which the concentration of platelets,  $c(h)$  is reduced by  $1/e$  every  $9 \mu\text{m}$  from the bottom of the container. It thus appears that, with or without flocculation, platelet settling is significant and cannot be dismissed as being unrelated to their short (a few days) lifespan in vitro.

## 4. Convection.

A study of early lattice formation in nucleating protein crystals (Kam et al., 1978) indicates that critical assembly processes occur at the submicron level. During lattice formation, the Gibbs free energy of crystallization is released to the immediate environment as heat, and solute is depleted near the lattice-forming surface. Both events lead to a local density reduction (Figure 2) with the potential for convection. The g-unloading of this process should, therefore, lead to higher quality crystal growth, which, evidently, it does (DeLucas et al., 1987; Bugg, 1987; Littke and John, 1982). Similarly, the formation of such self-assembled structures as microtubules (Weisenberg, et al, 1968) might be improved during g-unloading. Preliminary experiments by Moos et al (1988) indicate a more uniform length distribution of microtubules assembled during parabolic aircraft flight.

## ACKNOWLEDGMENTS

It is a pleasure to acknowledge introductions to this subject by C.A. Tobias and E.C. Pollard, stimulation to pursue it by D.R. Morrison, T.W. Halstead, E.K. Ray, and R.S. Bandurski, guidance from J.O. Kessler and A.H. Brown, and assistance with the preparation of this manuscript from J. Sibonga.

## REFERENCES

- Audus, L.J. 1962. The mechanism of perception of gravity by plants. *Symp. Soc. Exp. Biol.* 16, 197-226.
- Audus, L.J. 1964. Geotropism and the modified sine rule; an interpretation based on the amyloplast statolith theory. *Physiol. Plant.* 17, 737.
- Batchelor, G.K. and R.W. Janse van Rensburg, 1986. Structure Formation in Bidisperse Sedimentation. *J. Fluid. Mech.* 166: 379-407.
- Bugg, C.E. 1986. The Future of Protein Crystal Growth. *J. Crystal Growth.* 76: 535-544.
- Burki, H.J., T.J. Regimbal, Jr., and H.C. Mel. 1973. Zonal fractionation of mammalian metaphase chromosomes and determination of their DNA content. *Preparative Biochem.* 3, 157-182.
- Davson, H. and J.F. Danielli. *The Permeability of Natural Membranes.* 2nd Ed. Cambridge University Press, Cambridge, 1952.
- DeLucas, L.J., F.L. Suddath, R. Snyder, R. Naumann, M.B. Broom, M. Pusey, V. Yost, B. Herren, D. Carter, B. Nelson, E.J. Meehan, A. McPherson and C.E. Bugg. 1986. Preliminary Investigations of Protein Crystal Growth using the Space Shuttle. *J. Crystal Growth.* 76: 681-693.
- Edwards, B.F. 1969. Weightlessness experiments on Biosatellite II. *Life Sciences and Space Research.* W. Vishniac and F.G. Favorite, Eds. North-Holland, Amsterdam. 7,84-92.
- Fawcett, J. 1966. *The Cell: An Atlas of Fine Structure.* W.B. Saunders, Philadelphia.
- Gray, S.W. and B.F. Edwards. 1971. The effect of weightlessness on the growth and orientation of roots and shoots of monocotyledonous seedlings. In: *The Experiments of Biosatellite II.* J.F. Saunders, Ed., NASA SP-24, 123-166.
- Kam, Z., H.B. Shore and G. Feher. 1978. On the Crystallization of Proteins. *J. Mol. Biol.* 123: 539-555.
- Keith, A.D. and W. Snipes. 1974. Viscosity of cellular protoplasm. *Science.* 183, 666-668.
- Litke, W. and John, C. 1984. Protein Single Crystal Growth under Microgravity. *Science.* 225: 203-204.

- McNutt, N.S., L.A. Culp and P.H. Black. 1973. Contact-inhibited revertant cell lines from SV-40 transformed cells. IV. Microfilament distribution and cell shape in untransformed, transformed, and revertant Balb/C 3T3 cells. *J. Cell Biol.* 56, 412-428.
- Montgomery, P. O'B, P.O'B Montgomery Jr., J.E. Cook, R.C. Reynolds, J.S. Paul, L. Hayflick, D. Stock, W.W. Schulz, S. Kimzey, R.G. Thirolf, T. Rogers, D. Campbell and J. Morrell. 1974. The response of single human cells to zero gravity. In: *The Proceedings of the Skylab Life Sciences Symposium*. NASA document. TM x-58154. 467-491.
- Moos, P.J., K. Graf, M. Edwards, L.S. Stodieck, R. Einhorn and M.W. Luttgies. 1988. Gravity-induced changes in microtubule formation. Program and Abstracts, 4th Ann. Mtg. Amer Soc, Grav. Space Biol p. 55.
- Moskvitin, E.V. and E.N. Vaulina. 1975. Experiment with a physiologically active *Chlorella* Culture on "Soyuz-9" spaceship. *Space Biology and Aerospace Medicine.* 9(3):7-10.
- Pollard, E.C. 1965. Theoretical considerations on living systems in the absence of mechanical stress. *J. Theoret. Biol.* 113-123.
- Pollard, E.C. 1971. Physical determinants of receptor mechanisms. In *Gravity and the Organism*. Gordon, S.A. and Cohen, M.J. Eds. University of Chicago Press. p. 25-34.
- Prescott, D.M., D. Myerson and J. Wallace. 1972. Enucleation of mammalian cells with cytochalasin B. *Exp. Cell Res.* 71, 480-485.
- Saunders, J.F., ed. 1971. *The Experiments of Biosatellite II*. NASA SP-204.
- Schneider, E.L. and N. Salzman. 1970. Isolation and zonal fractionation of metaphase chromosomes from human diploid cells. *Science.* 167, 1141-1143.
- Shen-Miller, J. and C. Miller. 1972a. Intracellular distribution of mitochondria after geotropic stimulation of the oat coleoptile. *Plant Physiol.* 50, 51-54.
- Shen-Miller, J. 1972b. Participation of the Golgi apparatus in geotropism. In: *Plant Growth Substances 1970*. D.J. Carr, Ed. Springer-Verlag, Berlin. 738-744.
- Shen-Miller, J. 1972c. The Golgi apparatus and geotropism. In: *Hormonal Regulation in Plant Growth and Development*. H. Kaldeway and Y. Vardar, Eds. Verlag Chemie, Weinheim. 365-376.
- Shen-Miller, J. and C. Miller. 1972d. Distribution and activation of the Golgi apparatus in geotropism. *Plant Physiol.* 49, 634-639.
- Subramanian, R.S. 1987. The behavior of multiphase systems in low gravity. In: *Low Gravity Sciences*. Koster, J.N., Ed. American Astronautical Society.
- Surgenor, D.M. 1986. Blood formed elements in microgravity. *Blood.* 68:299.

- Taylor, G. 1977. Survey of cell biology experiments in reduced gravity. In: Bioprocessing in Space. Morrison, D.R., Ed. NASA TM X-58191. pp. 77-102.
- Tobias, C.A., J. Risius, and C.J. Yang. Biophysical considerations concerning gravity receptors and effectors. Lawrence Berkeley Laboratory Report. LBL-1012. Berkeley, CA, 1972.
- Todd, P. Gravity and the Cell: Intracellular structures and Stokes Sedimentation. In Morrison, D., Ed. Bioprocessing in Space. National Aeronautics and Space Administration Report NASA TM X-58191, Johnson Space Center, 1977.
- Van Alstine, J.M., L.J. Karr, J.M. Harris, R.S. Snyder, S.B. Bamberger, H.C. Matsos, P.A. Curreri, J. Boyce and D.E. Brooks. 1987. Phase partitioning in space and on Earth. In: Immunobiology of Proteins and Peptides IV. Atassi, Z., Ed. Plenum Publ. Corp. , NY. pp. 305-326.
- Weisenberg, R.C. G.G. Borisy and E.W. Taylor. 1968. The colchicine-binding protein of mammalian brain and its relation to microtubules. Biochemistry. 7, 4466-4479.
- Young, R.S. and J.W. Tremor. 1968a. Weightlessness and the developing frog egg. Life Sciences and Space Research. North-Holland, Amsterdam. VI. 87-93.
- Young, R.S. and J.W. Tremor. 1968b. The effect of weightlessness on the dividing egg of *Rana pipiens*. BioScience 18, 609-615.

TABLE I. HYDRODYNAMIC VALUES FOR A METAPHASE CHROMOSOME (SEE FIGURE 1) USED FOR APPLICATION TO EQUATION (2). CHROMOSOMES HAVE BEEN EXAMINED HYDRODYNAMICALLY IN ISOLATION (Burki et al., 1973; Schneider & Salzman, 1970), AND CYTOPLASMIC VISCOSITY HAS BEEN STUDIED BY PARAMAGNETIC RESONANCE (Keith & Snipes, 1974).

$$V = 2 \pi r^2 l = 25 \times 10^{-2} \text{ cm}^3$$

$$g = 980 \text{ cm/sec}^2$$

$$\rho - \rho_0 = 1.35 - 1.04 = 0.31 \text{ g/cm}^3$$

$$a = (3V/4\pi)^{1/3} = 2.1 \times 10^{-4} \text{ cm}$$

$$h = 5 \pm 2 \text{ dyn-sec/cm}^2$$

$$v = 2 \times 10^{-7} \text{ cm/sec}$$

TABLE 2. PHYSICAL PROPERTIES OF ORGANELLES USED TO CALCULATE STOKES' SEDIMENTATION VELOCITIES

<u>ORGANELLE</u>	<u>VOL</u> ( $\mu\text{m}^3$ )	$\rho$ ( $\text{g/cm}^3$ )	$\rho - \rho_0$	$v$ ( $\text{cm/sec}$ )	$t$ ( $\text{sec}$ )	$x$ ( $\mu\text{m}$ )	<u>FEATURE</u>
MITOCHONDRION	2-100	1.1	0.01-.02	$0.1-4 \times 10^{-8}$	$10^3$	0.1	Convolutd, large structure
NUCLEOLUS	10-20	1.4	0.3	$2 \times 10^{-7}$	$10^4$	20	Suspended by chromatin
CHROMOSOME	5-50	1.35	0.3	$2 \times 10^{-7}$	$10^3$	2	Suspended by $\mu$ tubules
AMYLOPLAST	100	1.5	0.4	$1 \times 10^{-6}$	$\leq 10^3$	10	Real free particle
OTOLITH	1000	2.0	0.8	$\geq 1 \times 10^{-5}$	1	0.1	Known to react
DICTYSOME	100	1.2	0.15	$\geq 3 \times 10^{-7}$	$10^3$	2	Internal membrane structure

Some data derived from Fawcett (1966).

TABLE 3. ORGANELLES THAT COULD SEDIMENT

<u>ORGANELLE</u>	<u>a, MICRONS</u>	<u>ORIGIN OF TENSILE FORCE</u>
NUCLEUS	5	10 NM FILAMENTS
NUCLEOLUS	1	CHROMATIN
CHROMOSOME	2	MICROTUBULES
CILIUM	4 - 10	MICROTUBULES
DICTYOSOME	2 - 6	MICROTUBULES

TABLE 4. STOKES' PARAMETERS FOR THROMBOCYTES IN PLASMA AND CALCULATION OF THEIR SEDIMENTATION VELOCITY

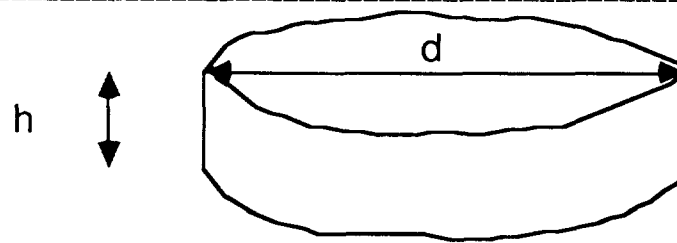

$$h = 0.5 \mu\text{m}$$

$$d = 3.0 \mu\text{m}$$

Equivalent Stokes' radius =  $0.94 \mu\text{m}$  from  $a = (3V/4\pi)^{1/3}$

Density from Geigy tables

$$\rho \text{ (platelet)} = 1.045 \text{ g/cm}^3$$

$$\rho \text{ (plasma)} = 1.0269 \text{ g/cm}^3$$

$$\eta \text{ (plasma)} = 1.10 \text{ cp} = 0.011 \text{ g/sec-cm}$$

Velocity

$$v = \frac{2(\rho - \rho_0) a^2 g}{9 \eta} = 0.01 \mu\text{m/sec} \approx 1 \text{ diameter/ } 5 \text{ min}$$



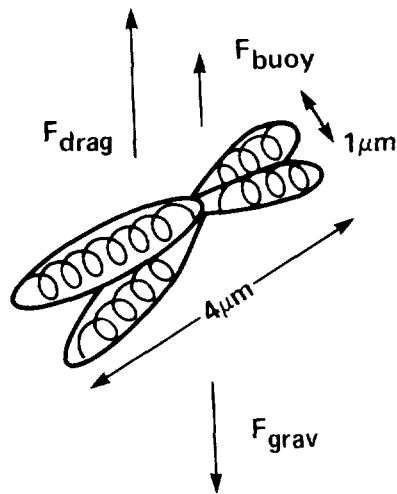

Figure 1. Balance of forces and dimensions of a metaphase chromosome sedimenting in free solution.

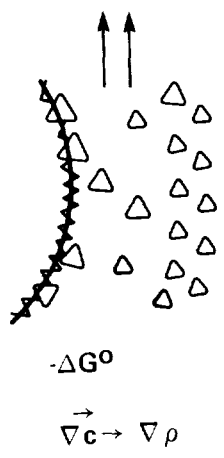

Figure 2. Events at the surface of a growing particle (crystal) that lead to fluid instability. The free energy of binding (or lattice formation) is released to the immediate fluid environment thereby raising its temperature and decreasing its density. At rapid growth rate, adsorption is more rapid than diffusion and solute concentration drops thereby decreasing the solution density. Both phenomena could lead to buoyancy of fluid at the growing surface.

## HOW TO DETECT WHEN CELLS IN SPACE PERCEIVE GRAVITY

Thomas Björkman  
 Department of Botany, KB-15  
 University of Washington  
 Seattle, WA 98195

It is useful to be able to measure when and whether cells detect gravity during spaceflights. For studying gravitational physiology, gravity perception is the response the experimentalist needs to measure. Also, for growing plants in space, plant cells may have a non-directional requirement for gravity as a developmental cue.

## GRAVITATIONAL PHYSIOLOGY

The main goals of spaceflight experiments in which gravity perception would be measured are to determine the properties of the gravity receptor and how it is activated, and to determine fundamental characteristics of the signal generated.

Measuring gravitropic curvature. The main practical difficulty with measuring gravity sensing in space is that we cannot measure gravity sensing with certainty on earth. Almost all experiments measure gravitropic curvature. Gravitropic curvature is measurable only when growth and growth regulation are functioning normally. This may not be the case in a space experiment and it certainly is not the case in cell culture.

Because the many physiological processes between perception and curvature can be influenced by environmental factors, particularly the gaseous environment, the conditions in which the experiments are done are particularly critical for experiments using gravitropic curvature as the assay.

Gravitropic variants and mutants have been hopefully used to learn about the mechanism of gravitropism, yet all seem to differ in transduction or response, not perception. That suggests that gravity perception is so fundamental that it is very rarely absent. It also means that gravitropic variants have been less helpful than expected in learning about gravity perception per se.

Gravitropic bending can be used to make inferences about gravity perception when appropriately used. Presentation-time measurements give a dose-response curve for perception with the response allowed to go to completion. By varying the gravitational force, the reciprocity between time and force can be used to test whether perception is a function of sedimentation (Johnsson, 1965). Intermittent stimulation with varied lengths of stimulation and intermission can give information about time averaging (e.g. sampling period), memory, and signal to noise ratio of the gravity receptor.

Reciprocity and intermittent stimulation are measurements which have been made to some degree on earth using clinostatting, but which would provide clearer results if done with microgravity rather than clinostatting. These would be important uses of the space laboratory for determining the nature of gravity sensing in plants.

Electrical measures of gravity sensing. Those techniques which do not use gravitropic curvature to measure gravity sensing are electrophysiological. These are based on phenomena which are correlated with gravity sensing, but

it is not yet known whether these are direct measures of gravity sensing or whether they are epiphenomena.

Two groups have measured depolarization of the membrane potential of cells in gravitropically responsive tissue. Behrens et al. (1985) measured depolarization of statocytes with a time scale closely corresponding to the presentation time. Ishikawa et al (1987) measured depolarization in cortical cells in the elongating zone of bean roots in much shorter times than the presentation time. The latter is rather curious because the electrical response preceded any other detectable response, and certainly preceded growth responses expected in the elongating zone. Further the cortical cells appear to have a minor role in gravitropic curvature (Björkman and Cleland, 1988). Dr. Ishikawa has designed a space experiment (Space Biology Experiment, Japanese H2 rocket) in which the depolarization of bean cortical cells is intended to detect gravity sensing.

Making intracellular impalements into specific plant cells is technically quite difficult and is not amenable to automation. Using this technique would require a large time investment on the part of a specifically trained payload specialist. In Dr. Ishikawa's experiment, the sample is placed in the apparatus before launch and the equipment is manipulated remotely from earth.

Two groups have also used a vibrating probe to measure changes in ionic currents around the gravity sensitive tissue. Behrens et al. (1982) made measurements indicating that currents were sensitive to changes in the gravity vector. Björkman and Leopold (1987a) made further investigations and found that the change in ionic current commenced coincident with the presentation time. They also found that the current was sensitive to calmodulin inhibitors (Björkman and Leopold, 1987b). Other data indicate that calmodulin is required to change diageotropism to orthogeotropism, but that it is not directly involved in gravity perception. Hence, the current is either a measure of transduction of perception to growth or that it is an epiphenomenon.

The vibrating probe would be somewhat easier to adapt to space conditions than the intracellular microelectrode because it can be positioned with less precision. However, it is subject to more experimental artifacts, so the training and effort required of a payload specialist is similar.

Ideally, a non-invasive technique would be best suited if an appropriate measure could be developed. External electrodes have been used for many years to measure the so-called geoelectric effect which has many guises, many of which are experimental artifacts. Nevertheless, tissue-level electrical responses of plants to gravity may be detectable with affixed electrodes. Another approach which I have not explored but which may be considered is Magnetic Resonance Imaging to detect consequences of altered electrical fields in the gravisensitive tissue.

Even if electrical measurements in fact detect epiphenomena, those which are strictly consequences of gravity perception may still be useful. A particular issue for which they may be used is to determine whether a gravisensitive tissue in its preferred orientation generates no signal or an equilateral signal. There is no way to test that at present, but it could be done by simply comparing the signal generated in a tissue in its preferred orientation at 1g and that at micro-g. Then these could be related to earth measurements of the intensity and distribution of signal when the tissue is gravistimulated.

At present there is no simple or unequivocal way to specifically measure gravity perception by plants. There is reason to expect that a fully-automated system could be developed based on electrical consequences of gravity

perception with non-invasive techniques (fluorimetry or magnetic resonance) being the most promising. In the meantime, there are microgravity experiments which can be done to make inferences about gravity perception. These are necessary for full benefit to be gained from easier indirect measurements in the future.

## CELL CULTURE

Another issue which concerns gravity sensing by cells in space is whether the presence of gravity is required for normal development. A different environmental stimulus which greatly affects development is light, with photomorphogenesis being regulated at very low light doses. Is there an analogous requirement for low doses of gravity? If so, it could be useful to be able to measure whether the cells are detecting gravity even when gravitropism is not an issue.

However, it seems unlikely that gravity serves as such a developmental cue because it is constant during development. In contrast, post-germination growth is usually in the absence of light which produces etiolated plants. These are well suited to growth underground and the response is therefore adaptive.

On the other hand, whereas plants have evolved with gravity present, do plants use it to perform work during development? The most likely process would be mitosis, because the mitotic apparatus is large enough to be significantly affected by gravity. Experiments with laser surgery on the mitotic spindle suggest, however, that the forces applied by the spindle are far greater than gravity.

On multicellular structures, gravity clearly has important mechanical consequences, but these can largely be grouped with thigmomorphogenesis. For example, the compression of a stem by the rest of the plant above it is essentially the same as the compression caused by wind moving the top of the plant about.

In a solution culture, the uptake of nutrients from the medium in a stationary flask in micro-g may be limited because there is no convection of the medium to accelerate diffusion. This response is interesting, but it is not a cellular response to microgravity.

Thus the effect of microgravity on cultured cells is likely to be by large-scale physical events rather than by gravity sensing in the cultured cells. I do not expect that it will be necessary to determine whether individual cultured cells perceive gravity unless cells grow abnormally even after the obvious microgravity effects on the culture as a whole can be ruled out the problem.

---

## References

- Behrens, H.M., M.H. Weisenseel and A. Sievers. 1982. Rapid changes in the pattern of electric current around the root tip of Lepidium sativum L. following gravistimulation. *Plant Physiol.* 70:1079-1083
- Behrens, H.M., D. Gradmann and A. Sievers. 1985. Membrane-potential responses following gravistimulation in roots of Lepidium sativum L. *Planta* 163:463-472

- Björkman, T. and R.E. Cleland. 1988. The role of the epidermis and cortex in gravitropic curvature of maize roots. *Planta*. 176:513-518.
- Björkman, T. and A.C. Leopold. 1987a. An electric current associated with gravity sensing in maize roots. *Plant Physiol.* 84:841-846
- Björkman, T. and A.C. Leopold. 1987b. Effect of inhibitors of auxin transport and of calmodulin of a gravisensing dependent current in maize roots. *Plant Physiol.* 84:847-850
- Ishikawa, H., N. Sawada, K. Tanaka, E. Ohta and M. Sakata. 1985. Proc. Second Space Util. Symp. ISAS, Tokyo. pp. 80-83
- Johnsson, A. 1965. Investigations of the reciprocity rule by means of geotropic and geoelectric measurements. *Physiol. Plant.* 18:945-967

EFFECTS OF MICROGRAVITY ON GROWTH HORMONE CONCENTRATION AND  
DISTRIBUTION IN PLANTS

Robert S. Bandurski,  
Aga Schulze, Philip Jensen and Mark Desrosiers  
Departments of Botany & Plant Pathology  
Michigan State University  
East Lansing, Michigan 48824-1312

ABSTRACT

On earth, gravity affects the distribution of the plant growth hormone, indole-3-acetic acid (IAA), in a manner such that the plant grows into a normal vertical orientation -- shoots up, roots down. How the plant controls the amount and distribution of IAA is only partially understood and is currently under investigation in this laboratory. The question to be answered in the flight experiment is: "How does gravity affect the concentration, turn over, and distribution of the growth hormone?" The answer to this question will aid in understanding the mechanism by which plants control the amount and distribution of growth hormone. Such knowledge of a plant's hormonal metabolism may aid in the growth of plants in space and will lead to agronomic advances.

INTRODUCTIONGround-based studies:

The shoot of a young plant, placed in a horizontal position, grows back to a vertical orientation (Figure 1). The response begins within minutes after the plant is placed horizontally and vertical orientation is restored at a rate of  $10^\circ \times \text{min}^{-1}$  (Bandurski et al, 1984). How the plant perceives gravity and how the gravity signal is transduced into an asymmetric growth response is only partially understood (Wilkins, 1984; Bandurski et al, 1986a). The plant's gravity response, and the lack of that response in micro-gravity, will be important in attempts to grow plants under micro-gravity conditions.

Gravity detection:

Owing to the pervasiveness of gravity, it is likely that plants sense gravity by more than one mechanism. For example, some plants may utilize the settling of dense starch grains, statoliths, to the bottom of the cell as a gravity-sensing mechanism (Bandurski et al, 1984; Sievers & Hensel, 1982). However, there is also evidence that a mutant plant, lacking phosphoglucosyltransferase in its chloroplasts -- and thus lacking starch-filled statoliths -- can sense gravity almost as readily as normal plants (Caspar T, Sommerville C. 1988. Personal Communication).

This mutant is detecting gravity without dense starch grains. Statoliths may perceive gravity in some plants but they are obviously not the only mechanism for gravity perception. For example, a mechanism for gravity sensing, not involving the settling of dense particles, has been proposed (Bandurski et al, 1986a). In this mechanism, any distortion of the cells' shape

or of the microtubular structures in the cytoplasm of the cell could be used for gravity sensing.

#### Membrane depolarization:

Despite the uncertainties regarding gravity sensing, it is known that both gravity and light stimuli result in membrane depolarization. This phenomenon has been studied for more than 50 years (Wilkins, 1984; Dolk, 1933) and has recently been studied elegantly by Tanada (1983) and by Sievers and colleagues (<sup>1</sup>Bandurski et al. 1988. In Press). Membrane depolarization is the first detectable response of a plant to a gravitational stimulus, occurring within 8 sec after the stimulus is given (<sup>1</sup>Bandurski et al., 1988. In Press). It is the rapidity of the depolarization response and its induction by two such diverse stimuli as gravity and light which suggests that membrane depolarization is an integral part of the tropic response.

#### Hormone asymmetry:

The next detectable response following membrane depolarization is an asymmetric distribution of the plant growth hormone, indole-3-acetic acid (IAA) (Bandurski et al, 1984; Bandurski et al, 1986a; <sup>1</sup>Bandurski et al, 1988). The central focus of our research has been the question, "How does the plant transduce a membrane depolarization into an asymmetric distribution of IAA?" We believe that emphasis on the chemical asymmetry, rather than on the more complex issue of growth asymmetry, will facilitate attaining an understanding of the gravity response at a molecular level.

#### A working theory:

This laboratory has developed a working theory for the transduction of the gravity stimulus into an asymmetric distribution of IAA. We postulate that a change in the orientation of the plant with respect to the gravitational field induces a membrane depolarization as discussed above (Bandurski et al, 1986a; Tanada, 1983; Behrens et al, 1985; <sup>1</sup>Bandurski et al, 1988) Next, we postulate that membrane depolarization open and/or closes plasmodesmatal channels between the plants vascular tissue and the surrounding cortical and epidermal tissues. IAA, calcium, and other substances, can then flow selectively into the bottom side of a horizontal stem inducing a more rapid growth rate on the bottom side of the stem. The plant would then grow into its normal vertical orientation. Evidence for this theory is reviewed in references Bandurski et al (1986a) and <sup>1</sup>Bandurski et al (1988).

#### Growth asymmetry:

Growth is complex involving the regulated occurrence of perhaps thousands of reactions. However, in our experimental system, employing 5 day old seedlings of corn (Zea mays), growth is an arithmetic function of IAA

<sup>1</sup>Bandurski RS, Schulze A, Desrosiers M, Jensen P, Epel B, and Reinecke D. 1989. Relationship between stimuli, IAA, and growth. In: Plant Growth Substances. 1988. Pharis R, Rood R, Eds. In press

concentration. Thus, we confirm and extend the earlier concepts (Went & Thimann, 1937) that growth is controlled by IAA and that an IAA asymmetry will result in a growth asymmetry.

#### Summary of ground-based research:

The intent of this laboratory has been to attempt to link membrane depolarization to a chemical asymmetry within the plant. The chemical asymmetry could then result in a growth asymmetry such that the plant grows back into its normal orientation.

In summary, the sequence of events is believed to be: 1) sensing of the gravitational stimulus; 2) transduction of the stimulus into a membrane depolarization; 3) transduction of the membrane depolarization into a chemical asymmetry; and 4) transduction of the chemical asymmetry into asymmetric growth.

#### Flight program:

We do not have a theoretical basis for predicting the effect of microgravity on the growth hormone IAA other than our working theory. We know that at 1 g, IAA becomes asymmetrically distributed within a horizontally-placed plant. We believe this asymmetric distribution to be owing to selective movement of IAA from the vascular stele into the surrounding cortical tissues with more IAA coming from the lower side of the stele. The flight experiment will tell us whether the channels between stele and cortex are open or closed in the absence of the gravitational stimulus. This knowledge will be of value in understanding how plants regulate their endogenous IAA levels and may help in the growing of the plants in space.

### RESULTS

#### Synopsis of the experimental protocol:

The plant seeds (kernels) are wrapped in filter paper, loaded into canisters and water added 12 h prior to launch. Two canisters and one LN<sub>2</sub> freezer are placed in each of two middeck lockers. The plants are allowed to grow for 108 h (total hydration plus growth time equals 120 h) at which time two of the canisters are permitted to grow until shuttle landing. Upon landing the two unfrozen canisters and the two prefrozen canisters are put into a 35 VHC, Taylor-Warton liquid nitrogen refrigerator. After several hrs, the frozen canisters are transferred to a dry-ice shipping container, loaded with solid CO<sub>2</sub> and sent to East Lansing for analytical studies. In East Lansing, the plants will be dissected into roots, seed, and shoot tissue and ground in aqueous acetone for extraction and determination of free and ester IAA.

#### Experimental design:

The plants must be grown in darkness, in microgravity, and frozen prior to landing. We have designed the plant growth container to minimize crew handling time and eliminate the possibility of plant material or moisture escaping into the mid-deck of the shuttle. Figure 6 shows a photograph of the canisters used for plant growth. There are two compartments to each



canister. Table I summarizes the weight, contents and dimensions of the canisters.

TABLE I

Canister length	335.0	mm
Canister diameter	82.0	mm
Canister weight	860.0	g
(There are 2 compartments per canister)		
14 Teflon sleeves (7.07g ea) X2=	19.08	g
28 filter papers (2.15g ea) X2=	121.0	g
(Two filter papers per kernel)		
14 kernels(0.197g ea) X2=	5.52	g
water(8 m/kernel) X2=	224.0	g
Total per canister	1408.52	g
One fully charged LN2	14,870.0	g

So 4 canisters would weigh 5634 g and 2 fully charged LN2's would weight 29740g for a total experiment weight of 35374 grams.

#### Gas exchange:

The canisters are vented through 4 light baffled holes to permit gas exchange with the air of the middeck locker. As can be seen in Figure 2, the venting is adequate to prevent the build-up of CO<sub>2</sub> and there is no benefit by adding an ethylene absorbent. Figure 3 shows that the venting is adequate to prevent depletion of oxygen and again there is no benefit by adding an ethylene absorbent.

We conclude that the canisters are adequately vented for the growth of 28 seedlings during 120 h growth period.

#### The assay for IAA:

An important part of both the ground-based studies and the flight program has been the development of a sensitive and reliable assay procedure for IAA. Owing to the lability of IAA, its presence in low ( $10^{-8}$  M) concentration, and the presence of  $10^{-3}$  M interfering phenylpropene acids, an internal standard must be employed. Colorimetric, fluorometric, and radioimmunoassays have proven useless (Pengelly & Bandurski, 1983; Cohen et al, 1987). The following assay has proven to be sensitive and accurate and provides proof that it is really IAA that is being measured. We originally synthesized 4,5,6,7-tetra deuterio IAA as an internal standard (Magnus et al, 1980) but this has now been replaced by IAA labeled with 6 atoms of <sup>13</sup>C in the benzene ring portion of the indole nucleus (Cohen et al, 1986).

#### Extraction of IAA from the plant tissue:

The plants from the two canisters frozen in space will be separated into shoots, seeds, and roots, weights recorded and the plants then homogenized in sufficient acetone to make the final acetone concentration 70%. (All percentages are vol/vol.) The plants from the remaining two canisters will

be treated similarly and used as "controls" since they will have had, at least, 90 minutes of recovery time at one, or more, g. Ground controls will be similarly treated. The homogenates will be filtered, residues washed and weighed, and the volume of the aqueous acetone extracts determined. Two thirds of each extract will be used for the determination of free IAA and one third will be used for determination of esterified IAA. To each extract a known amount of  $^{13}\text{C}$  IAA will be added in amounts such that the  $^{13}\text{C}$  IAA will range between 1 to 10 times the plant IAA. In addition, about 540,000 DPM of 22.6 Ci/mmole tritiated IAA will be added. This amount (1,884 picograms of 5- $^3\text{H}$ -IAA is one mass unit heavier than the plant's IAA and further is only 9.4% of the IAA of a 1 g sample containing 20 ng of IAA per g) and so does not interfere with the assay but facilitates locating peaks on chromatograms. The aqueous extracts are concentrated in vacuo, made to 50% aqueous ethanol, applied to a 2 ml bed volume DEAE-acetate column and the column washed with 10 column volumes of 50% ethanol-water to remove non-anionic compounds. The column is then gradient eluted with 50 ml of 50% acetic acid in the mixing flask and 50 ml of 50% aqueous ethanol containing 5% acetic acid in the reservoir. IAA elutes at about 20 ml. The samples for determination of free plus ester IAA will have been treated similarly except that the samples will first be hydrolyzed with 1 M NaOH for 15 min at 22°C, then adjusted to pH 2.5, and the IAA extracted into ether, concentrated, taken up in 50% aqueous ethanol and treated as above.

The pooled IAA containing sample is reduced to near dryness (50  $\mu\text{l}$  of capryl alcohol was added to prevent foaming and to prevent the sample from going to dryness) in vacuo, taken up in 200  $\mu\text{l}$  of 50% aqueous ethanol and applied to a 4.8 mm X 250 cm C18 reverse phase HPLC column. Development is with 30% aqueous ethanol containing 0.1% acetic acid. The radioactive sample is collected at about 12 ml, dried in vacuo, taken up in 100  $\mu\text{l}$  of methanol, methylated with 300  $\mu\text{l}$  of ethereal diazomethane (Bandurski et al, 1986b), dried and taken up in 20 to 50  $\mu\text{l}$  of acetonitrile for GC-MS.

Gas chromatography is on a 12.5 m 0.2 mm wall coated OV-17 column butt connected to 15 cm of 0.5 mm uncoated quartz pre-column and using direct on column injection. The GC-MS is the Hewlett-Packard 5890-5970 table top model. As shown in Figure 4, the chromatography is very good, and as shown in Figure 5, the ratio of amounts of material at masses 189 and 195 and 130 and 136 is easily determined. Mass 189 is the molecular ion of methyl IAA and 136 is the quinolinium ion of  $6\text{C}^{13}$  IAA. The ratios of ions at 195/189 and 136/130 agree within 0.1% giving assurance that only pure IAA is being measured.

#### EXPECTED BENEFITS

As indicated above, there is no adequate theoretical basis for predicting the effects of gravity, or the lack of gravity, on biological systems. Mammalian systems, although of primary importance in terms of humans in space, appear terribly complicated and may be less suited than plants and microorganisms for attaining an understanding of gravity effects at the molecular level.

We believe that our system, utilizing 5 day old dark-grown corn plants is possibly the best eucaryotic plant system available. It is a closed system since, in darkness, the plants must obtain all of their nutrients and their growth hormone, IAA, from seed (Bandurski et al, 1986a; 1Bandurski et al, 1988; Bandruski et al, 1986b; Reinecke & Bandurski, 1987). Further, we have evidence that the targets for the gravitational response on earth, are the

plasmodesmatal channels connecting the vascular tissues of the stele with the cortical and epidermal tissues.

We have not completed our electrophysiological studies and so we can not predict whether the plasmodesmatal channels will be open or closed in microgravity. However, following the flight experiment we will be able to measure the size of the plants, their dry weight, how much IAA and IAA conjugates are in the shoot and, importantly, the amount of IAA and IAA conjugates left in the shoot. Such knowledge will provide another important set of facts which must be fit into any working theory for the molecular basis of the gravity effect on plants.

Such knowledge will be of practical value to terrestrial agriculture. Whether this knowledge will result in important advances in space technology is unknown. If there are no important microgravity effects, it will be of aid to the space station program to know there are no fundamental hormonal problems that prevent a successful agriculture in space. If there are microgravity effects than it is possible that a technology based upon substitution of electrical potentials for the gravitational stimulus might be of practical value in facilitating a space based agriculture (Desrosiers & Bandruski, 1988). Either result must ultimately fit into theories concerning how a plant regulates its endogenous hormone levels.

#### OBJECTIVE

We know that hormones control growth and development, but what controls the amount of the hormone? That is the ultimate objective of this experiment.

#### REFERENCES

- Bandurski, R.S., A. Schulze, P. Dayanandan, and P.B. Kaufman. 1984. *Plant Physiology*. 74:284.
- Bandurski, R.S., and A. Schulze, W. Domagalski. 1986a. XXVI COSPAR Adv Space Res. 6:47.
- Bandurski, R.S., A. Schulze and D.M. Reinecke. 1986b. Biosynthetic and metabolic aspects of auxins. p83. In: *Plant Growth Substances*. 1985. Bopp M, Ed. Springer-Verlag, Heidelberg.
- Behrens, H.M., D. Gradman, and A. Sievers. 1985. *Planta*. 163:463.
- Cohen, J.D., B.G. Baldi and J.P. Slovin. 1986. *Plant Physiology*. 80:14.
- Cohen, J.D., M.G. Bausher, K. Bialek, J.G. Buta, G.F.W. Gocal, L.M. Janzen, R.P. Pharis, A.N. Reedand and J.P. Slovin. 1987. *Plant Physiology*. 80:961.
- Desrosiers, M.R. and R.S. Bandurski. 1988. *Plant Physiology*. 87:874.
- Dolk, H. 1933. *Rec Trav Bot Neerl*. 33:509.
- Pengelly, W.L. and R.S. Bandurski. 1983. *Plant Physiology*. 73:445.
- Magnus, V., A. Schulze, and R.S. Bandruski. 1980. *Plant Physiology*. 90:961.

- Reinecke D.M. and R.S. Bandurski. 1987. Auxin biosynthesis and metabolism.  
In: Plant hormones and their role in plant growth and development.  
Davies P, Ed. Nijhoff-Junk Publishers, Netherlands. p24.
- Sievers A. and W. Hensel. 1982. The nature of graviperception. pp 497-506. In:  
Plant Growth Substances. Wareing PF, Ed. Academic Press, New York.
- Tanada, T. 1983. Plant, Cell, Environ. 6:69.
- Went, F.W. and K.V. Thimann. 1937. Phytohormones. MacMillan New York.
- Wilkins, M.B. 1984. Gravitropism. pp. 153-185. In: Advanced Plant  
Physiology. Wilkins MB, Ed. Pitman London.

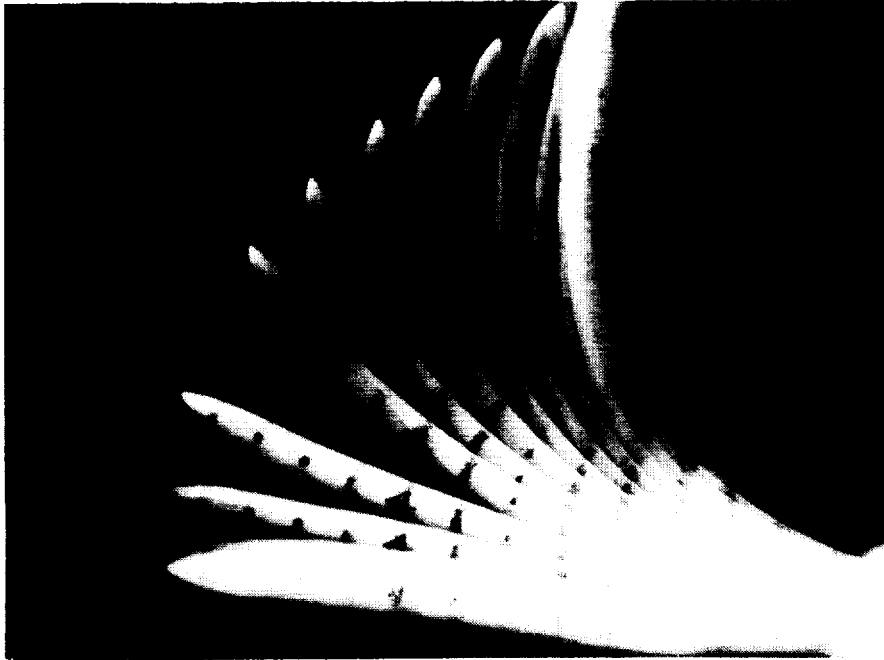

Fig. 1. Time lapse photograph of a seedling of *Z. mays* during gravitropic curvature. The initial photograph was taken just as the seedling was placed horizontally. Successive photographs are taken at 15-min intervals. The India-ink marked 'N' indicates the node between the coleoptile and mesocotyl..

ORIGINAL PAGE  
BLACK AND WHITE PHOTOGRAPH

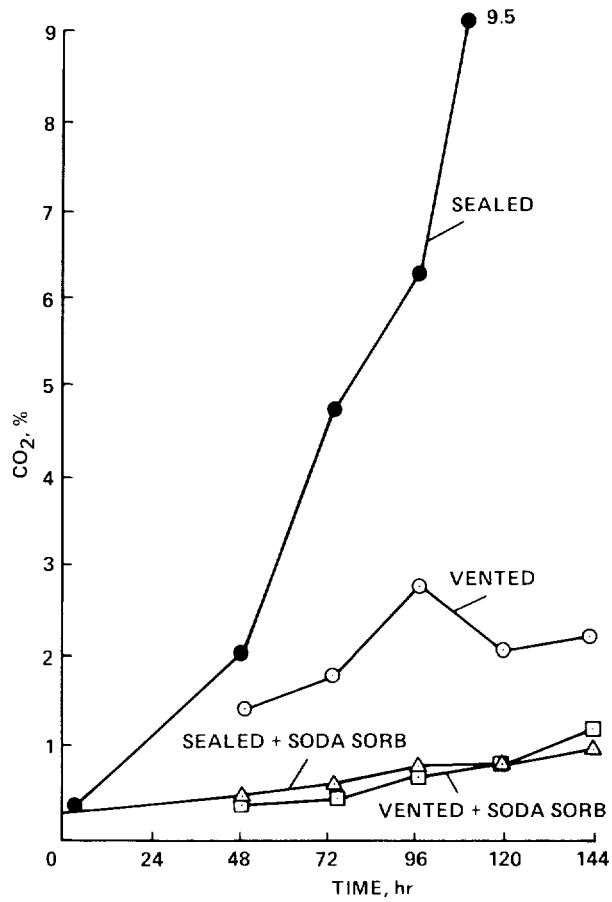

Fig. 2. Venting the canister prevents the build up of carbon dioxide so that a CO<sub>2</sub> absorbent such as soda sorb need not be added. Each compartment of the canister contained 14 germinating kernels of corn (*Zea mays*) for 120 h.

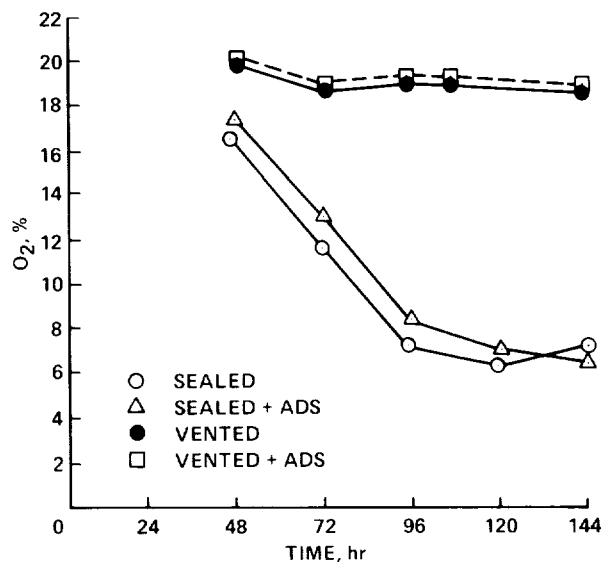

Fig. 3. Venting the canister prevents oxygen depletion. Addition of an ethylene and carbon dioxide absorbent did not change the per cent oxygen in the gas phase. Each compartment of the canister contained 14 germinating kernels of corn (*Zea mays*) for 120 h.

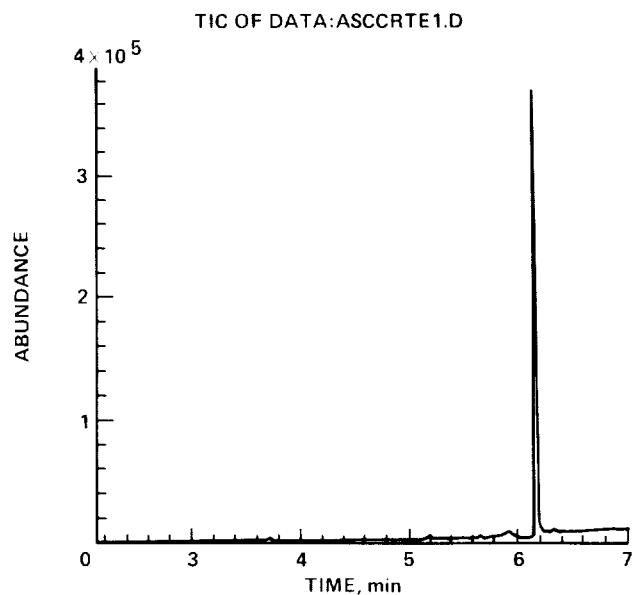

Fig. 4. Total ion current monitored as a function of retention time on a 12.5m OV-17 WCOT. As can be seen the purified and methylated IAA from the plant is almost free of any contaminants. This, possibly excessive, purification prior to GC/MS assay keep the injector and columns clean and improves our day to day sensitivity.

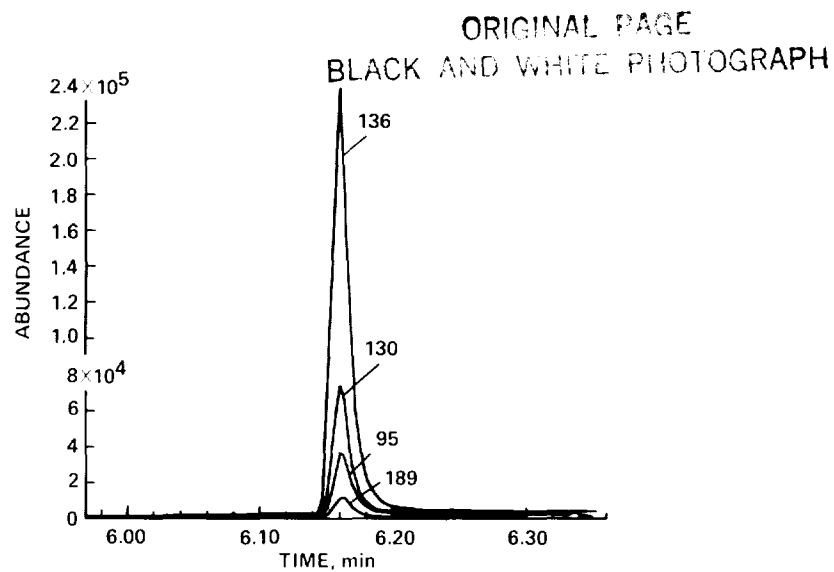

Fig. 5. Monitoring of masses 195 and 189, the molecular ions of the methyl ester of <sup>6</sup>C<sup>13</sup> IAA and plant IAA, and 136 and 130, the quinolinium ions of <sup>6</sup>C<sup>13</sup> IAA and plant IAA. Agreement of the ratio 195/189 and 136/130 is usually within 0.1% giving assurance that the compound being measured is, in fact, IAA.



Fig. 6. A photograph of the plant canister separated into its two compartments. The lid screws into the top of one compartment which then screws into the bottom compartment to comprise the canister of two compartments. Construction is of anodized aluminum.



## GRAVITY RECEPTORS AND RESPONSES

Allan H. Brown  
 Gravitational Plant Physiology Laboratory  
 University City Science Center  
 3401 Market St., Suite 350  
 Philadelphia, PA 19104-3323

OVERVIEW---Components of G sensing and response processes in plants.

The overall process may be divided conveniently into at least four components or stages: (a) Stimulus susception: a physical event, characteristically the input to the G receptor system of environmental information about the G force magnitude, its vector direction, or both; (b) Information perception: an influence of susception on some biological structure or process that can be described as the transformation of environmental information into a biologically meaningful change; (c) Information transport: the export, if required, of an influence (often chemical) to cells and organs other than those at the sensor location; and (d) biological response: almost always (in plants) a growth change of some kind. Some analysts of the process identify, between (b) and (c), an additional stage, transduction, which would emphasize the importance of a transformation from one form of information to another, for example from mechanical statolith displacement to an electric, chemical, or other alteration that was its indirect result.

These four (or five) stages are temporally sequential. Even if we cannot confidently identify all that occurs at each stage, it seems evident that during transduction and transport we must be dealing with matters to be found relatively late in the information flow rather than at the perception stage. As we learn more and more about the roles played by plant hormones which condition the G responses, we are not necessarily able to understand better the mechanism(s) of perception which should be our focus in this Session. However, if by asking the right questions and being lucky with our experiments perhaps we can discover how some process (such as sedimentation of protoplasmic organelles) dictates what happens down stream in the information flow sequence.

GRAVITY FORCE AS A CONTINUOUS VARIABLE

Gravity is different things to different specialists. To some, nominal zero G is a stress to which hominids "adapt." Chronic G forces above zero but less than unity may seem important as experimental conditions chiefly to discover if there is a G threshold above which certain stress responses (euphemistically called adaptation) can be endured without progressive unacceptable sequelae. From that view point unit G is especially important as a "control," easily accessible on earth and supplied in orbit only by a centrifuge. However, plant and animal physiologists who work with small organisms are apt to consider gravity not necessarily as a stress but in a general sense as an environmental factor—one of the top three or four in order of importance to organisms. Like other conditions that affect plants these scientists must be able to control experimentally the G force vector direction and intensity over the full range of possible G levels from nominally zero to as far above 1 G as may seem

scientifically interesting. Thus, viewing G as a continuous experimental variable, we tend to think of the control condition not as 1 G but as weightlessness. Unit G becomes one of many abscissal G levels that occur when plotting the G function of a particular biological effect. This view point has not been readily accepted by some experts in space medicine; it is widespread in the general biological community.

#### GRAVITY SENSING AS A CENTRAL QUESTION FOR UNDERSTANDING HOW GRAVITY IS IMPORTANT TO PLANTS

For the better part of a century, plant physiologists have recorded a large number of descriptive studies of plant responses to gravity — more precisely to experimentally controlled changes in the direction in which the earth's gravity force acts on the plant. Relatively recent advances in methodology and improved biological and biochemical background information have encouraged the belief that we may be on the verge of dramatically improved understanding of the mechanism(s) by which gravity is sensed and those by which biological responses are generated. Nevertheless, we are still at a stage in our science where purely descriptive studies are urgently needed. Only infrequently have our theories been challenged by decisive experimental tests. Since the experimental potential for gravitational physiology has been dramatically enhanced in the last three decades by the promise of full control over the total range of experimentally applied G forces, a large number of new questions arise which call for new exploratory experiments to describe quantitatively the gravity sensing process in test organisms. Gravity sensing, although not a new area of study, has enjoyed greatly increased priority as a process to be studied by new methods created or enhanced by space flight technology. Physiologists, each in his own phylogenetic area of choice, seem to be in at least intuitive agreement that scientific progress is highly likely in the area of gravity sensing by exploiting the new technology. Broadly stated the question is: How is gravity important to plants? The central question that now drives most experimental designs is: How does the organism sense gravity?

#### TOOLS FOR EXPERIMENTATION

Exploration or experimentation with biological responses to any environmental factor requires control and quantitative manipulation of the factor of interest, in our case, the gravity force. It is interesting that the three major tools needed for creating, maintaining, or simulating G levels are all rotating machines.

The centrifuge probably is the most familiar. In earth laboratories centrifuges have been used to impose G forces ranging up to about 500 G for long periods in exploratory experiments with small plant seedlings (Gray and Edwards, 1955; Brown, 1983). For small organisms only a few G units above normal may be considered non-stressful and can contribute to studies of G sensing in the hypergravity G range (Brown et al, 1975). At much higher forces (10s or 100s of G units) stress reactions patently dominate even though the test species often adapts morphologically to growth in the strange environment.

For application to space experimentation various advisory groups have repeated essentially the same recommendation urging a "1 G control" aboard the spacecrafts although only recently has the recommendation been implemented, first by Soviet and later by ESA experimenters.

A unit G control in space also would be subjected to all known and unknown artifactual influences of the spacecraft (shock and vibration, for example) and of its environment (especially ionizing radiation). If all such artifacts were understood and could be measured, it would be possible to perform adequate control experiments on earth. However, skeptics always will be hard to convince that there are not some unknown influences which could deceive the investigators. The least expensive way to allay such fears would be to provide the often recommended 1 G control centrifuge in space even though the important issue really has little to do with biological effects of G forces per se. There remains, as a most compelling argument for flying on-board centrifuges, the need to access the hypogravity region of the G parameter,  $0 < G < 1$ . (Cf. contribution of D. K. Chapman in this report.)

Potentially the unit G condition also can be achieved in space by rotating the space vehicle about its center of mass. However, if we want not merely to avoid the necessity for humans' adaptation to microgravity but also want to carry out scientific experiments in hypogravity, a centrifuge would still be required, in that case with its rotational axis exactly coincident with that of the rotating space vehicle.

The centrifuge has been used on earth to extrapolate data from a series of tests at different hypergravity G levels to the ordinate axis intercept which thereby becomes a qualified estimate of what value of the measured parameter would obtain if the test could be performed at zero G. The qualification of course, is the assumption of linearity (or some other function) beyond the range accessible to experimentation. In a very few cases the assumption of linearity was disproven but at this stage of our understanding of the effects of protracted hypogravity it is impossible to generalize.

The clinostat (Sachs, 1882) is another rotating device widely used by plant physiologists to simulate hypogravity conditions on earth. It is described and evaluated by D. K. Chapman in this report. The simulated condition of zero G, achieved by clinostatting generally is referred to as "gravity compensation". How well that condition gives biological responses which are the same as those of tests in free fall remains a question that must be addressed empirically. Less than a handful of such comparisons have been accomplished and the conclusions were not in agreement (Lyon, 1968; Merkys et al, 1975; Brown et al, 1974; Brown and Chapman, 1984). It does not seem prudent to generalize at this stage of our science (Brown et al, 1976).

The rotating machine most recently added to our list of tools for experimentation is the spacecraft in earth orbit. Its radius of rotation (about  $7 \times 10^6$  km) is somewhat larger than that of our earthbound centrifuges and clinostats. Its rotation rate in near earth orbit is much less (approximately  $2 \times 10^{-4}$  Hz). In stable circular orbit the G force at the center of gravity of the spacecraft closely approximates zero in the sense that no force other than gravity perturbs it; thus it establishes the ideal condition of free fall.

By itself, the spacecraft in orbit is theoretically capable of providing only one G value, nominally zero. However, by combining the satellite's potential with the capability of an onboard centrifuge, an experimenter can attain a protracted G force environment of any desired intensity, from zero to however much his experiment requires. The centrifuge is needed to impose a controlled, constant, centripetal force on the test subject otherwise in a state of free fall.

It may be of interest, for those experiments which require a very low G environmental condition, that the centrifuge axis should remain parallel to the orbital axis of rotation of the spacecraft. Whether the spacecraft is gravity gradient stabilized, or rotates slowly in its orbital plane, makes little difference: However, rapid spacecraft maneuvers can produce gyroscopic effects which should be considered. They may or may not be small enough to be ignored.

#### TO SENSE GRAVITY DOES ANYTHING HAVE TO MOVE?

Gravity perception can be accomplished by a variety of different mechanisms. Given that something is being influenced by gravity (or by an equivalent inertial force) that influence can be detected by dozens of physical or physical chemical mechanisms devised by engineers and physicists as well as by those, whose numbers we are in doubt, that were invented by biological systems in the course of their evolution.

For those devices invented by scientists, their mechanisms seem to have nothing in common except that all are based on ways of detecting movement. Many such devices have been invented and their detectors, amplifiers, and methods of readout are diverse. It would be arrogant for us to pretend that biological means for detecting mass movement are so much less sophisticated that only one or even only a few methods of gravity detection are employed by organisms. Nevertheless, over the past century plant physiologists have been prone to generalize (at least implicitly) the amyloplast sedimentation mechanism not only as the earliest process in G perception but as if it were, in principle, the only device plants learned to use for detecting gravity susception.

To put the matter in perspective three things should be kept in mind. (a) In spite of widespread occurrence of patently sedimenting organelles (statoliths such as large starch-filled amyloplasts or inorganic crystals, viz. barium sulfate) there are numerous examples of gravisensitive plant organs whose cells do not contain mobile organelles sufficiently more or less dense than the cytosol so that they sediment under conditions that prevail for G responding plants. According, in statocytes devoid of starch loaded amyloplasts some less obvious mechanism must exist to account for the evident consequences of gravity susception. Where no obviously functional statoliths have yet been found, we should not assume that those cells are incapable of sensing gravity. (b) It is impossible for any bioaccelerometer or for any man-made device to detect the susception of gravity unless something moves. Whether we call the perturbation falling, twisting, stretching, bending, compression, displacement, stratification, sedimentation, acceleration, or altered momentum cannot change the fact that the act of susception must be to alter something's position, shape, or acceleration. That categorical conclusion

is based on a fundamental physical principle. (c) Gravity is a body force. Acting on every particle of mass in an object, it imparts to that object its weight. An inertial force also is a body force. Acting on every particle of mass in an object, if unopposed, it gives to that object an acceleration. According to the Principle of Equivalence, it is quite impossible for experiments to differentiate between inertial forces and gravitational forces within one frame of reference. By placing an object in earth orbit it becomes weightless because it continues to be acted on only by a gravitational force. Therefore it is better to refer to its condition as free fall rather than as zero gravity. All other forces that could oppose free fall and establish equilibrium (hence weight) are absent. A particle of mass in orbit is at rest in an inertial reference frame. It remains in uniform motion as long as no other force acts on it. Because inertial and gravitation forces are equivalent, a centripetal force of any desired magnitude applied to the particle produces the same effect as would a gravitational force of the same magnitude. This is the basis for establishing a 1 G "control" condition in a satellite.

A suggested subtopic of this Session Item was, "Could gravity responses be pressure responses?" In the sense that a pressure change is suggested as an alternative to a movement, the answer is emphatically no, for reasons stated above. However, whatever moves could be responsible for (or a consequence of) a pressure change. Pumping up a flat automobile tire, for example, leads to both a small amplitude movement (centimeters) and large change of pressure (from ca. 100 k Pa to ca. 300 k Pa). It is of no consequence that we are accustomed to measuring tire inflation with a pressure gage instead of a tape measure (unless we "eyeball it" in which case the distention is estimated, not the pressure.)

With respect to plant cells, Björkman (1988) argued against a G sensor mechanism based on cells' manometric versatility, among other reasons because of the large normal fluctuations of resting pressures in plant cells. Normally cells in growing organs carry a mean pressure of about 300 to 600 k Pa above atmospheric (101.3 k Pa). However, over time during the growth process and under different conditions of water availability, extremes of internal pressures in plant cells may fall as low as -1500 k Pa and as high as +2000 k Pa, limits which are conservative estimates. Such enormous fluctuations would make it very difficult for a plant organ to detect (and to reliably interpret as gravity induced) pressure changes of very much smaller magnitude.

Moreover, by bending and restraining gravisensitive plant shoots and roots, the contralateral stretching and compression of the growing organ does not "fool" the G sensing mechanism. When released from constraint the tropistic response proceeds as would be expected from an apically located sensor that perceives only the G vector. Thus it becomes, if not impossible, at least very awkward to attempt construction of a G sensing theory that depends at any stage on a bioaccelerometer measurement of internal cell or tissue pressure.

## CONCLUSION

In both animals and plants those responses which follow the act of sensing gravity ultimately involve whole organs---often the whole organism. Cell specialization is well developed in higher organisms that sense gravity. In

plants the sensor function usually resides mostly in a small group of cells, less than 1% of total tissue mass (rarely in only a single cell). These cells, the sensing organ, is sometimes referred to as a bioaccelerometer. It responds to gravity susception always by some kind of movement. In most cases this involves sedimentation of mobile organelles or stratification of zones of the cytoplasm. There is no evidence that G perception involves cooperation between cells although the consequences of G sensing undoubtedly show summation of activities of all sensor cells. Thus G perception in plants is a uniquely cellular function as it must be where it is accomplished in unicellular forms. The sensing-response process can be divided, at least conceptually, into several stages. Recent advances have told us more about how organisms, especially plants, use the gravitational information they acquire. When we are able to fully exploit the potential of experiments in microgravity and at any other gravity level the experiments require, we may find progress on how plants acquire gravitational information may outdistance that on other areas of gravitational biology.

#### REFERENCES

- Björkman, T. 1988. Perception of gravity by plants. *Adv. Botan. Res.* 15: 1-41.
- Brown, A.H. et al. 1974. A comparison of leaf epinasty induced by weightlessness or by clinostat rotation. *Bioscience* 24: 578-520.
- Brown, A.H. et.al. 1975. Morphology of Arabidopsis grown under chronic centrifugation and on the clinostat. *Plant Physiol.* 57: 358-364.
- Brown, A.H. et al. 1976. Limiation on the use of the horizontal clinostat as a gravity compensator. *Plant Physiol.* 58: 127-130.
- Brown, A.H. 1983. Resistance of mature Arabidopsis plants to mechanica deformation in relation to G-force during development. *The Physiologist* 26 (No.6) Suppl. 149-150.
- Brown, A.H. and D.K. Chapman. 1984. Circumnutation observed without a significant gravitational force in spaceflight. *Science* 225: 230-232.
- Gray, S.W. and B.F. Edwards. 1955. Effects of centrifugal forces on growth and form of coleoptile of wheat. *J. Cell. Comp. Physiol.* 46:97-126.
- Lyon, C.J. 1968. Wheat seedling growth in the absence of gravitational force. *Plant Physiol.* 43: 1002-1007.
- Merkys, A.J. et al. 1975. The development of seedling shoots under space flight conditions. *Life Sciences and Space Research* 13: 53-57.
- Sachs, J. 1882. *Über Ausschliessung der geotropischen und heliotropischen Krümmungen während des Wachsens.* *Arb. Bot. Inst. zu Würzburg* 2: 209-225.

## FREE SWIMMING ORGANISMS: MICROGRAVITY AS AN INVESTIGATIVE TOOL†

John O. Kessler  
Physics Department  
University of Arizona  
Tucson, AZ 85721

## ABSTRACT

On Earth, micro-organisms are in the grip of gravitational and viscous forces. These forces, in combination with sensory stimuli, determine the average orientation of the organisms' swimming trajectories relative to the fluid environment. Microgravity provides the opportunity to study the rules which govern the summation of orienting influences and to develop quantitative physical measurements of sensory responses, e.g. the measurement of phototactic orientation tendency in torque units. Also, by reducing or eliminating density anisotropy-driven buoyant convection, it will be possible to study illumination, temperature gradient and concentration gradient-mediated collective dynamics.

The chief cause of up-swimming of most algal cells is their orientation by the Earth's gravity field. This surprising result can be easily demonstrated by their upward accumulation, in the dark, within porous media such as cotton or sand (Kessler, 1985a,b; 1986a; U.S. Patents 4,324,067, 1982 and 4,438,591, 1984). Further proof of the influence of gravity is provided by the symmetry of gyrotactic focusing (Kessler 1986a,b; 1985 a,b). This effect uses compensating torques acting on swimming cells. One component is due to gravity, which acts on the cells' anisotropic mass distribution. The other is viscous drag, due to velocity gradients (vorticity) of the embedding fluid. Gravity and vorticity combine to specify the mean orientation of the cells' swimming vector, so that they swim toward the axis of a downward laminar pipe flow. This focusing of the cells is reversed in an up-flow: the cells then swim toward the periphery of the pipe.

When the cell concentration is low, the generation of a gyrotactically focused cell population has a negligible effect on the supplied Poiseuille flow field of the fluid, which at its entrance point usually contains uniformly dispersed cells. Since the equations which describe the laminar Poiseuille flow are well-known, one may calculate the vorticity and rate of strain of the fluid, and thus the viscous torque on cells of known dimensions (Pedley and Kessler, 1987). That being so, one may then infer the magnitude of the gravitational torque which, together with gravity, co-orient the cell. The vorticity torque measures the gravity torque in terms of orientation of a cell's

† Since this paper relates to an oral presentation, it is organized in an unusual manner. The main section is a general discussion of significance and research objectives. The Appendix contains figures and figure captions which represent the original graphic material. The figures are not explicitly referred to in the main section. A section of general comments, which relates both to this paper and some other issues, is located between the main part and the Appendix.

swimming vector. Because of the random behavior of cells is superimposed upon their deterministic behavior, and because of the polydispersivity of cell populations in size, swimming speeds, etc, the previous statement is true only on the average. We have generally modeled these stochastic aspects of cell populations by a diffusion term in the cell flux (see Appendix figures).

It should be evident that gyrotactic focusing disappears under micro-gravity conditions. *Unloading the force of gravity* therefore provides the opportunity for using gyrotaxis to measure the turning tendency of cells due to other important influences, such as illumination!

Swimming cells and other micro-organisms actively respond to sensory stimuli. But, in addition, for the case of motile algae, gravity and viscous torques orient the cells physically. There is no intervention of sensory channels or metabolic change! The response of cells to illumination results from sensory processes and metabolic requirements which may change over the cells' life cycle. Thus, the cells' response to light is not only qualitative (direction sensitivity) but quantitative (Haeder, 1987).

Normally, algal cells' response to light is measured in terms of accumulation or histogram units. However, the possibility now exists for measuring the photic intensity/direction preferences of the cells by gyrotaxis, which yields a result that is numerical and stated in terms of torque units (e.g. dyne-cm)! This novel proposal for quantifying physiological responses of individual cells is likely to bring about entirely new methods in cell biology, biotechnology, and in the field of phytoplankton ecology.

There are several reasons for requiring gravity unloading for performing these experiments. The first is clear definition of procedure. Because, in an Earth laboratory, there are usually three cell-orienting influences in a "phototaxis" experiment (light, vorticity, gravity), and because we do not yet know their summation rules, the space experiment will be less ambiguous because of the elimination of one of the three orienting influences. However, the ground-based experiment (at various  $g \geq 1$  levels) is required also, to provide methodological experience and continuity in the development and testing of sum rules. The details are beyond the scope of this paper. The second reason for embracing g-unloading is the fact that collective gravitational convection, briefly discussed in the next section, may skew phototaxis data. The third reason for requiring g-unloading is the fact that the gravity field may sensitize or desensitize phototaxis by orienting the cells, or by polarizing their contents. There is some conceptual evidence for this situation in the case of *Volvox*, a negatively geotactic and generally positively phototactic colonial alga. Another way of stating this point: We do not know whether gravitational orientation is interconnected with phototaxis. There are effects of internal self-shading, axial rotation, differential stress, and cytoplasmic streaming (Kessler & Bier, 1977; Kessler, 1979) which may produce such an interaction. The fourth reason involves the need for eliminating stimulus-driven convection, as in thermotaxis measurements.

### Collective Effects

Single motile cells may swim upwards because of gravitational orientation, illumination, temperature gradients, or, in the case of *Bacillus subtilis*, toward increasing concentration of oxygen. Whatever the cause of individuals' upswimming, the net result is a density inversion, since cells are generally denser than water. Normally, this density inversion is dynamically unstable;



it results in collective convection/concentration patterns (Pedley et al, 1988; Childress et al, 1975). For upswimming algae, gravity interacts twice: once for upswimming and once for collective-mode generation (see Appendix figures). If one wishes to study collective effects other than gravity-driven convection modes, the experimentation can only be unambiguously accomplished in a microgravity environment. This further aspect of g-unloading will be described in more detail in a later paper.

The remarkable formation of convection patterns by aerotactic *B. subtilis* may provide some insights. When these motile cells are suspended in a shallow open-surface culture, they swim toward the upper interface, the source of oxygen. Since they cannot swim through the fluid-air interface, they accumulate there, producing a density inversion; that geometry is gravitationally unstable. Descending cell-laden streamers form in regular patterned arrays. They transport not only cells, but oxygen-rich fluid from the vicinity of the interface. This dynamic situation is maintained by upswimming of individual cells and by downward transport of concentrated cell populations in streamers.

It would not be possible, on the ground, at  $g=1$ , to measure aerotaxis of concentrated swimming bacterial populations without some generation of convective modes - which, by advecting the dissolved gas, obfuscate the basic process. On the other hand, the measurement of bacterial taxes at low cell concentration is likely to yield quite different results compared with the ones obtained with culture conditions which prevail at high cell concentration ... Is the preceding statement true? There is really no sure way to know except by measurements made under microgravity conditions.

#### Summary

- 1) The trajectories of individual swimming cells are guided by
  - a) physical orienting mechanisms, e.g., gravity and vorticity, and
  - b) sensory orienting mechanisms, e.g., light, chemical concentration gradients.
- 2) Gravitational and sensory orienting tendencies may interfere.
- 3) Gyrotaxis can be used to quantify sensory orienting mechanisms in terms of physical (torque) units.
- 4) This gyrotactic quantitation must be at least calibrated in microgravity: It may be necessary to use microgravity for all such measurements.
- 5) Collective effects of cell population often include two interactions with gravity:
  - a) orientation of individual cells
  - b) bioconvection, driven by cell swimming
- 6) Sensory phenomena of swimming cells that are members of large populations can be measured unambiguously only in microgravity.

#### General Comments on Related Conference Themes

- 1) Effect of microgravity upon cells

It is inappropriate to ask about "the effect of microgravity upon cells." It should be evident that, because gravity orients individual cells' locomotion and mediates convection/concentration patterns, the elimination or "unloading" of the gravitational force also eliminates effects caused by it. g-

Unloading eliminates multi-effect ambiguity. It also permits investigation of joint action of gravitational and sensory mechanisms. Similar remarks can be made with respect to other than swimming cells

## 2) Thermal noise effects

Although the mass anisotropy Boltzmann factor  $mgh/kT$  is generally small for intracellular phenomena (and the associated rotational diffusion tends to be large), it is not small for collective effects that extend over cell populations or, indeed, for individual cells  $\geq 5$  microns in diameter. Furthermore, it does not adequately measure the relative influence of gravity and temperature on active, recursive, collective effects. The actual magnitudes of  $g$  vs. thermal noise effects must be considered on a case-by-case basis, taking into account recursive addition of coherent nonlinear phenomena which are mediated by gravity. It should be clear that when gravity and thermal noise effects are commensurate at one  $g$ , microgravity (e.g.,  $10^{-4} g$ ) is analogous to removing gravity altogether. In these cases "microgravity" and "zero gravity" are equivalent.

Intermittent motions of a space vehicle can produce convection pulses in fluid experiments. These motions conventionally are quantified as some value of micro- $g$ . Actually, the implication that they are therefore harmless is often inaccurate. Convection pulses are likely to upset a fluid-based experiment by stirring, by producing vorticity, etc. One may conclude that, for many situations, an unmanned space vehicle, such as LifeSat, is the laboratory of choice.

## 3) Clinostats

Clinostats never simulate "zero- $g$ ." In a solid or rigid system, they may simulate "zero- $g$ -direction." The averaging to zero of the  $g$ -direction unit vector does not nullify the gravitational stress - it just changes its direction at the clinostat rotation rate. An isotropic liquid which completely fills its container and rotates at a constant rate can be considered a rigid system. If a liquid "on a clinostat" is anisotropic or contains several phases, if it contains suspended solid particles, or if it does not fully fill its container, not even "zero- $g$ -direction" is simulated for the liquid or its contents.

## References List

- Childress, S., M. Levandowsky and E.A. Spiegel. 1975. Pattern formation in a suspension of swimming micro-organisms. *J. Fluid Mech.* 63, 591-613.
- Haeder, D.P. 1987. Polarotaxis, gravitaxis and vertical phototaxis in the green flagellate *Euglena gracilis*. *Arch. Microbiol.* 147, 179-183.
- Kessler, J.O. and M. Bier. 1977. Gravitational dynamics of biosystems, in Materials Sciences in Space, Progr. in Astronautics and Aeronautics, V. 52, L. Steg and M. Summerfield, Eds. pp. 125-149.
- Kessler, J.O. 1979. Gravity sensing, polar transport and cytoplasmic streaming in plant cells. *The Physiologist*, v. 22 Suppl., 47-48.

- Kessler, J.O. 1982. Algal Cell Harvesting, U.S. Patent 4,324,067.
- Kessler, J.O. 1984. Algal Cell Growth, Modification and Harvesting, U.S. Patent 4,438,591.
- Kessler, J.O. 1985a. Hydrodynamic focusing of motile algal cells. *Nature, Lond.* 313, 218-220.
- Kessler, J.O. 1985b. Cooperative and concentrative phenomena of swimming micro-organisms. *Contemp. Phys.* 26, 147-166.
- Kessler, J.O. 1986a. The external dynamics of swimming micro-organisms. In: *Progress in phycological research* (ed. F.E. Round). 4, pp257-307.
- Kessler, J.O. 1986b. Individual and collective fluid dynamics of swimming cells. *J. Fluid Mech.* 173, 191-205.
- Pedley, T.J. and J.O. Kessler. 1987. The orientation of spheroidal micro-organisms swimming in a flow field. *Proc. Royal Soc. Lond.* B231, 47-70.
- Pedley, T.J., N.A. Hill and J.O. Kessler. 1988. The growth of bioconvection patterns in a uniform suspension of gyrotactic micro-organisms. *J. Fluid Mech.* 195, 223-237.

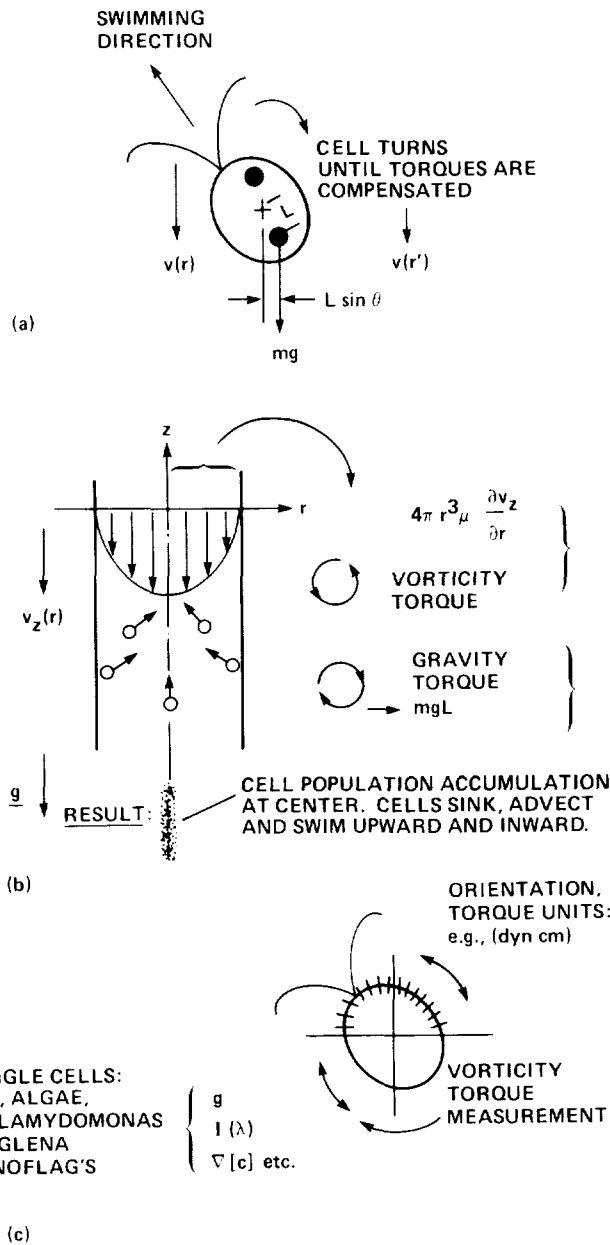

Fig. 1. (a) Orientation of cell is determined by torque compensation:  $mgL \sin$  is the gravity torque (clockwise). The vorticity torque is also clockwise, since  $v(r') > v(r)$ . This situation prevails in (b), left-hand side of diagram. For torque compensation, the cell turns until it is oriented as in (b), left-hand side. (c) illustrates possible replacements for the gravity torque, illumination  $I(\lambda)$  and chemical concentration gradient  $\nabla[c]$ .

GEOTAXIS + VISCOUS DRAG → GYROTAXIS

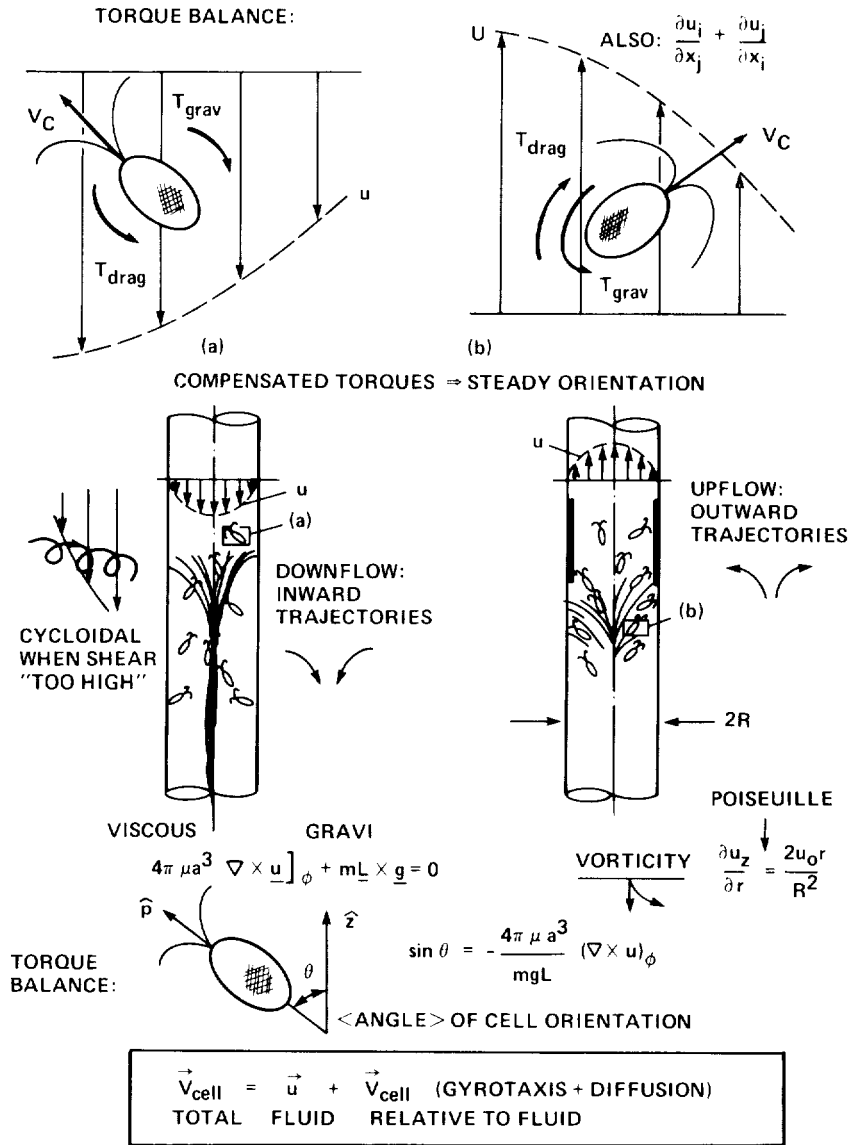

Fig. 2. The basic equations which govern cell orientation. The left diagrams show swimming toward the axis of a Poiseuille downflow; the right diagrams show the outward trajectories in an upflow.



Fig. 3. Cell-laden fluid flows downward in the left half of a U-tube, upward on the right. The cells on the left focus toward the axis; on the right, they have accumulated to the tube's periphery where, because of their high concentration, they form downward streamers (with J. E. Simpson).

ORIGINAL PAGE  
BLACK AND WHITE PHOTOGRAPH

GYROACTIC FOCUSING

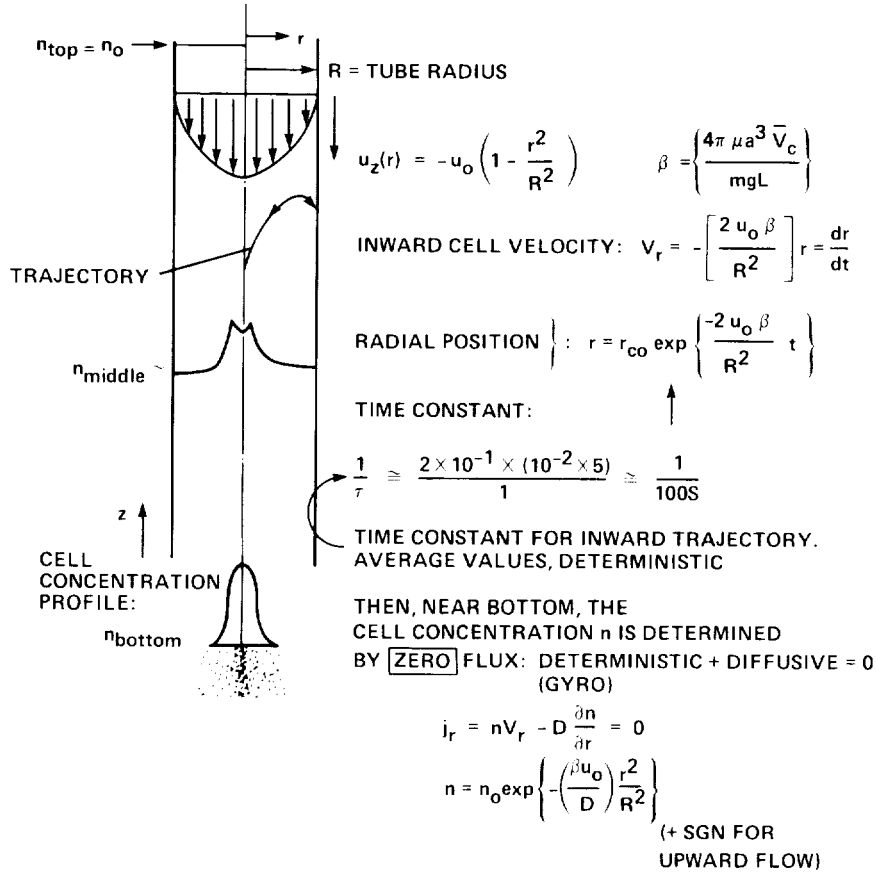
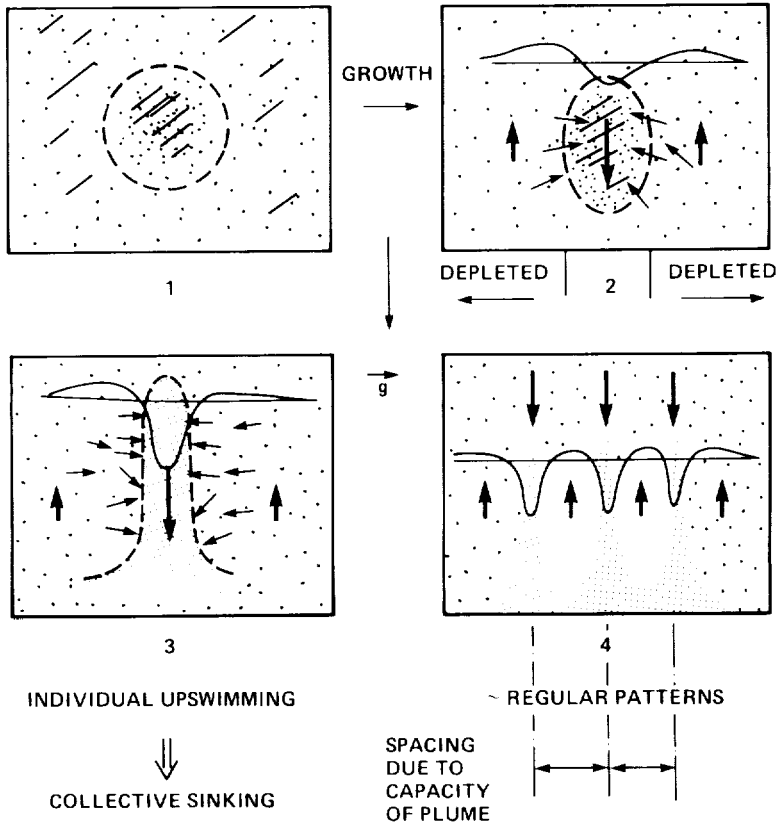

Fig. 4. Equations of focusing. The cell flux is modeled by a deterministic velocity factor,  $V_r$ , and a diffusive factor which summarizes stochastic behavior. The fluid velocity field is  $u(r)$ .

GROWTH OF CELL CONCENTRATION FLUCTUATIONS

NUCLEATION: (1) "OLD  $\nabla \times \underline{u}$ " REMAINING FROM MIXING  
(2)  $\rho (= n)$  FLUCTUATION



(ONCE WE KNOW TRAJECTORY EQUATIONS & etc. )

PERTURBATION GROWTH RATE POSITIVE, WHEN

$$\left( \frac{\tau_{\text{DIFFUSION}}}{\tau_{\text{GYRO OF SINKING COLUMN}}} \right) \cong \left( \frac{n_0 (\Delta\rho/\rho) v g \beta \Lambda^2}{4 D v} \right) > 1 \quad \text{etc. PATT. SCALE}$$

$n_0$  = CELL CONC.  
 $\Delta\rho$  =  $\rho_{\text{CELL}} - \rho_{\text{WATER}}$   
 $\rho$  =  $\bar{\rho}$   
 $v$  = CELL VOLUME  
 $g$  =  $10^3 \text{ cm/s}^2$   
 $\beta$  = GYROTACTIC CONST  
 $D$  = DIFFUSIVITY OF CELLS  
 $v$  = KINEMATIC VISCOSITY  
 $\Lambda$  = RADIAL DIMENSION

J. FLUID MECHANICS (DEC. 1986) 173, 191-205

Fig. 5. The growth of fluctuations, leading to pattern formation. In the upper of the figures, the heavy arrows indicate fluid motion; the light arrows show cell swimming. The arrow between the four panels shows the down directions.



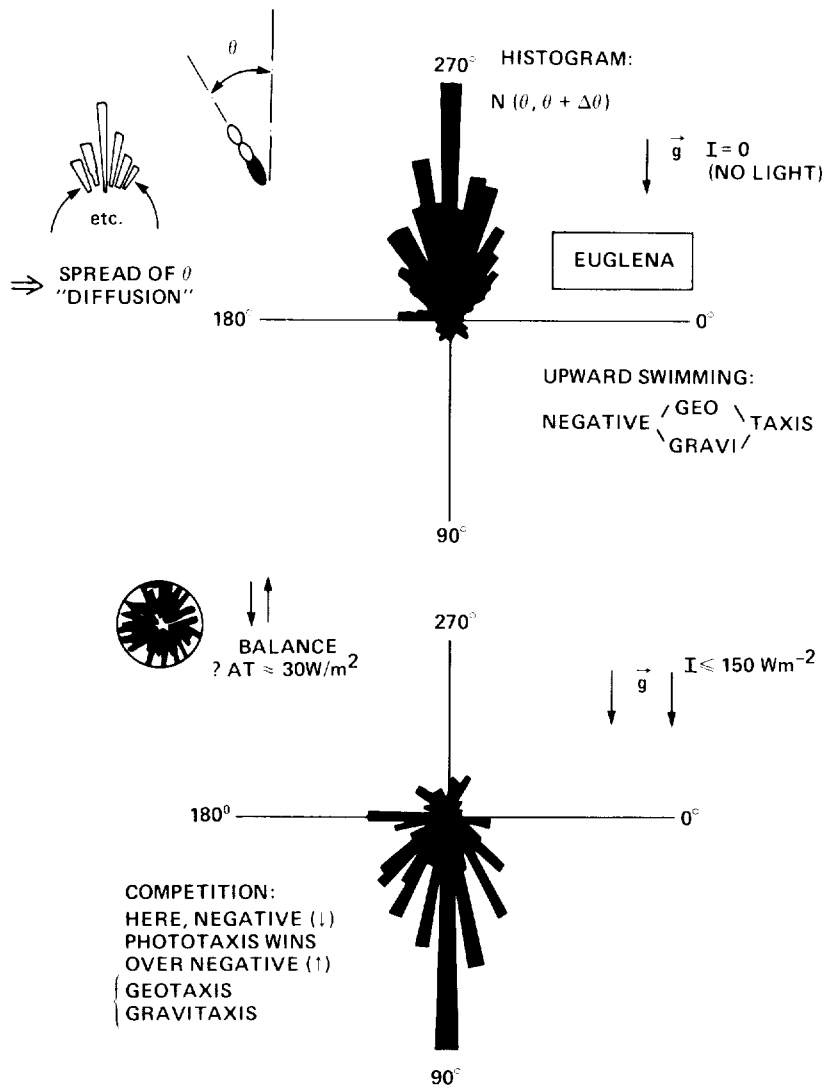

D. HÄDER ARCH. MICROBIOL. (1987) 147, 179-18

Fig. 6. *Euglena gracilis* swims upward in the dark, but downward in strong illumination from above. An example of multiple guiding influences.

ASYMMETRIC AUTOMATON:

- (1) MOVES (NO CURRENT ENERGY REQUIREMENT)
- (2) INTERACTS WITH SYMMETRY – BREAKING FIELDS:  $\underline{g}, \nabla \times \underline{u}$ 
  - (a) INDIVIDUALLY (ALIGN)
  - (b) COLLECTIVELY (SINK)

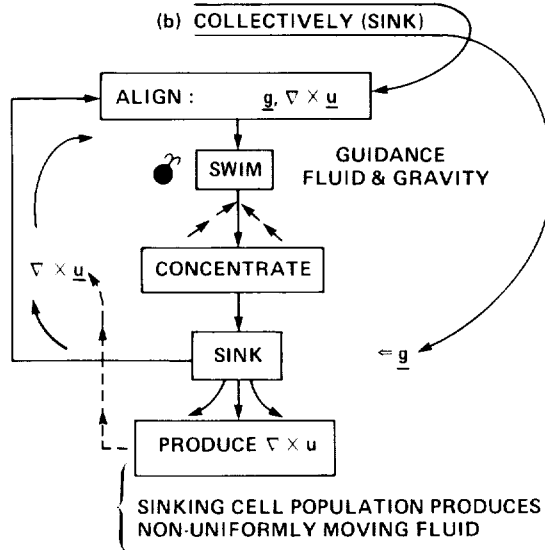

AT  $\underline{g} = 0$ , ONE (BUT NOT BOTH!) INTERACTIONS WITH GRAVITY CAN BE REPLACED BY PHOTOTAXIS (!!)

Fig. 7. Flow chart showing the collective interactions that give rise to algal convection/concentration patterns.

ORIGINAL PAGE  
BLACK AND WHITE PHOTOGRAPH



Fig. 8. Self-generated pattern of algal self-concentration and fluid convection (*Chlamydomonas nivalis*).

ORIGINAL PAGE  
BLACK AND WHITE PHOTOGRAPH

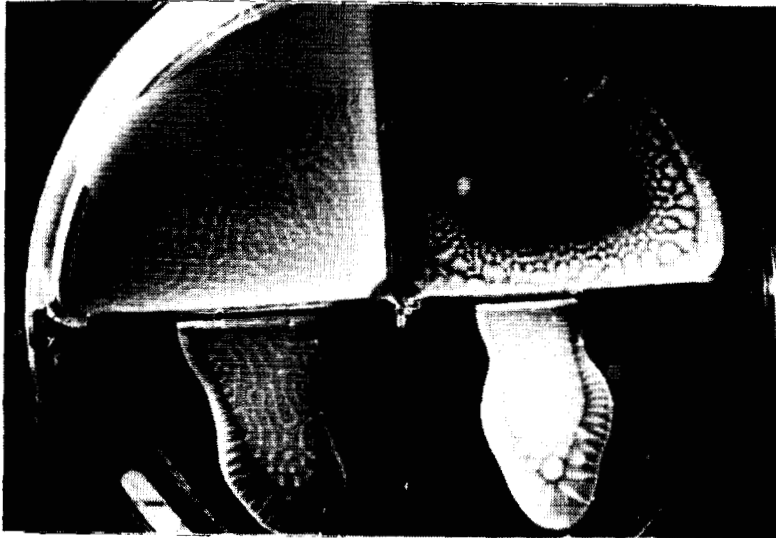

Fig. 9. Self-generated concentration/convection patterns of *B. subtilis*. The pattern results from upswimming toward the air interface. The quadrants of the petri dish contain various depths of the same culture (with M. A. Hoelzer).

## GRAVITROPISM IN PLANTS: HYDRAULICS AND WALL GROWTH PROPERTIES OF RESPONDING CELLS

Daniel J. Cosgrove  
Department of Biology  
Pennsylvania State University  
University Park, PA 16802

## INTRODUCTION

Gravitropism is the asymmetrical alteration of plant growth in response to a change in the gravity vector, with the typical result that stems grow up and roots grow down. The gravity response is important for plants because it enables them to grow their aerial parts in a mechanically stable (upright) position and to develop their roots and leaves to make efficient use of soil nutrients and sunlight. The elucidation of gravitropic responses will tell us much about how gravity exerts its morphogenetic effects on plants and how plants regulate their growth at the cellular and molecular levels.

## PATTERNS OF ALTERED GROWTH

Marker studies of the gravitropic response of various young plants have shown that the curvature results from a reduction of growth on the upper surface and a stimulation of growth on the lower stem surface (Gordon, Macdonald, Hart & Berg, 1984; Digby & Fim, 1979; Carrington & Fim, 1983). In my studies (Cosgrove, in press), young cucumber seedlings show a lag of ten minutes before the upper stem surface ceases elongation entirely and the lower surface doubles its expansion rate. Although the curvature appears to originate at the apex and migrate basipetally, in fact the response occurs simultaneously along the length of the stem. The appearance of the "wave propagation" results from the diminishing growth rate and magnitude of growth response in more basipetal parts of the stem.

## GROWTH BIOPHYSICS

Expanding plant cells are highly vacuolate (perhaps 95% of the cell volume is vacuolar), they are constrained by a tough, fibrous, polymeric cell wall, and they are pressurized to a value of about 4-8 atmospheres (Cosgrove, 1986). As a result, the wall is under considerable tension (equivalent to thousands of pounds per square inch) and a major problem for expanding cells is how to yield to these wall stresses and enlarge the cell without rupturing the wall and thus cell. Beside wall expansion, cell enlargement also requires uptake of water, since the volume increase occurs principally by enlargement of the vacuole, which is filled with a watery solution. The requirements of wall expansion and water uptake have been put together in a biophysical model of plant growth (Cosgrove, 1986; Lockhart, 1965), which envisions two coupled processes: (a) cell turgor pressure generates the mechanical driving force for wall expansion via shearing and expansion of the constituent wall polymers and (b) wall expansion and relaxation reduces cell turgor pressure and water potential, thus creating the driving force for water uptake and volume expansion.

During gravitropism, the changes in cell expansion correspond to changes in water uptake, and in principle they could be caused by changes either in the water uptake properties of the expanding cells, or in their cell wall growth properties. Using the pressure probe to measure cell turgor pressure directly, I found that turgor of the cells remained nearly constant during the gravitropic response of cucumber stems. Other measures of the osmotic and hydraulic characteristics of the cells also showed little if any alteration during gravitropism. Thus, the altered growth appeared to be the result of altered cell wall properties. The mechanism of wall relaxation and its alteration during gravitropism is not yet understood, but hypotheses center around enzymatic loosening of the cell wall, with control via alteration of the ionic environment of the extracellular space.

#### IONIC CHANGES IN THE CELL WALL.

Recent studies have accumulated evidence that gradients in hydrogen and calcium ions in the cell wall free space (apoplast) are intimately connected with the gravitropic growth response. At present the role of such ionic changes in the wall has not been adequately deciphered: they may have direct effects on cell wall extensibility, on auxin and solute transport, and/or on membrane function.

Mulkey, Kuzmanoff and Evans (1981) visualized pH asymmetries in gravitroping roots and stems by placing the seedlings on agar containing a pH indicator. In this and related studies, gradients in wall pH were not directly measured, but were implied from the pattern of acidification of the external medium. Other studies have shown that this pH asymmetry is apparently essential for the expression of growth asymmetry (Wright & Rayle, 1982; Schurzmann & Hild, 1980; Wright & Rayle, 1983). Such observations are in line with the acid-growth hypothesis which proposes that auxin stimulates growth by acidifying of the cell wall space (Rayle & Cleland, 1977; Cleland & Rayle, 1978). The acidic pH in turn promotes loosening of the wall which consequently extends more readily under the influence of the cell's hydrostatic pressure (turgor pressure). In agreement with this concept is the observation that horizontal sunflower segments fail to curve upward when treated with neutral buffers (Wright & Rayle, 1982). Also, when a lateral pH gradient is imposed on cucumber stems, they are induced to curve (Iwami & Masuda, 1973). It is easy to imagine, then, that an asymmetry in auxin (or other hormone) leads to an asymmetry in pH of the cell wall, and consequently an asymmetry in growth.

A major unanswered question regarding this acid-growth mechanism is whether the changes in pH are sufficient to account for the observed changes in growth rate. Recent reports from two different laboratories have questioned whether proton efflux induced by auxin is sufficient to account for auxin stimulation of growth (Vesper, 1985). However, no direct measurements of wall pH were made in these studies, and since the large ion-exchange capacity of the walls can alter exchange with the external medium, a compelling test of the hypothesis is still lacking. It is remarkable that so little direct information is available concerning the pH of the wall under various conditions.

In addition to hydrogen ions, calcium ions are also believed to play an essential role in gravitropism. In coleoptiles, calcium appears to accumulate in the walls of the upper side, that is, on the inhibited side (Slocum & Roux, 1983). Calcium acts as an inhibitor of wall expansion and chelation of calcium promotes wall expansion (Baker & Ray, 1965a; Cleland & Rayle, 1977; Cooil & Bonner, 1957; Tepfer & Cleland, 1979). Moreover, chelators of calcium and calmodulin antagonists block gravitropism with little or no inhibition of elongation (Daye, Biro & Roux, 1984; Lee, Mulky & Evans, 1983). However, the mechanism by which calcium modulates gravitropism is still uncertain (58,34). Calcium appears to have direct effects on the wall and on putative wall loosening enzymes (Cleland & Rayle, 1977; Jarvis, Logan & Duncan, 1984; Cooil & Bonner, 1957; Moll & Jones, 1981; Baker & Ray, 1965b). Moreover, because auxin transport and calcium are interlinked (DeLa Fuente, 1984) and calcium mediates many cell functions, it is likely that calcium functions in more than one fashion during gravitropism.

In summary, the majority of the evidence indicates that gravitropic asymmetry in growth arises from an alteration of the cell wall growth properties on the two sides of the stem. Although wall pH and pCa are implicated in the growth response, further quantitative work is necessary to assess the magnitudes of the ionic changes in the wall during gravitropism and their significance to the altered wall properties.

#### LITERATURE CITED

- Baker, D.B., and P.M. Ray. 1965a. Direct and indirect effects of auxin on cell wall synthesis in oat coleoptile tissue. *Plant Physiology* 40: 345-352.
- Baker, D.B., and P.M. Ray. 1965b. Relation between effects of auxin on cell wall synthesis and cell elongation. *Plant Physiology* 40: 360-368.
- Carrington, C.M.S., and R.D. Firm. 1983. Cell enlargement during gravicurvature of sunflower hypocotyls. *J Exp Bot* 34: 283-290.
- Cleland, R.E., and D.L. Rayle. 1977. Reevaluation of the effect of calcium ions on auxin-induced elongation. *Plant Physiology* 60: 709-712.
- Cleland, R.E., and D.L. Rayle. 1978. Auxin, H<sup>+</sup>-excretion and cell elongation. *Bot Mag Tokyo Special Issue* 1: 125-139.
- Cooil, B.J., and J. Bonner. 1957. The nature of growth inhibition by calcium in the *Avena* coleoptile. *Planta* 48: 696-723.
- Cosgrove, D.J. 1986. Biophysical control of plant cell growth. *Ann Rev Plant Physiology* 37: 377-405.
- Daye, S., R.L. Biro, and S.J. Roux. 1984. Inhibition of gravitropism in oat coleoptiles by the calcium chelator, ethyleneglycol-bis-(B-aminoethyl ether)-N,N'-tetraacetic acid. *Physiol.Plant* 61: 449-454.
- DeLa Fuente, R.K. 1984. Role of calcium in the polar secretion of indoleacetic acid. *Plant Physiology* 76: 342-346.

- Digby, J., and R.D. Firm. 1979. An analysis of the changes in growth rate occurring during the initial stages of geocurvature in shoots. *Plant Cell & Environ* 2: 145-148.
- Gordon, D.C., I.R. Macdonald, J.W. Hart, and A. Berg. 1984. Image analysis of geo-induced inhibition, compression, and promotion of growth in an inverted *Helianthus annuus* L. seedling. *Plant Physiology* 76: 589-594.
- Iwami, S., and Y. Masuda. 1973. Hydrogen ion-induced curvature of cucumber hypocotyls. *Plant Cell Physiol* 15: 757-762.
- Jarvis, M.C., A.S. Logan, and H.J. Duncan. 1984. Tensile characteristics of collenchyma cell walls at different calcium contents. *Physiol Plant* 61: 81-86.
- Lee, J.S., T.J. Mulky, and M.L. Evans. 1983. Reversible loss of gravitropic sensitivity in maize roots after tip application of calcium chelators. *Science* 220: 1375-1376.
- Lockhart, J.A. 1965. An analysis of irreversible plant cell elongation. *J Theor Biol* 8: 264-275.
- Moll, C., and R.L. Jones. 1981. Calcium and gibberellin-induced elongation of lettuce hypocotyl sections. *Planta* 152: 450-456.
- Mulkey, T.J., K.M. Kuzmanoff, and M.L. Evans. 1981. Correlations between proton-efflux patterns and growth patterns during geotropism and phototropism in maize and sunflower. *Planta* 152: 239-241.
- Rayle, D.L., and R.E. Cleland. 1977. Control of plant cell enlargement by hydrogen ions. *Curr Topics Dev Biol* 11: 187-214.
- Schurzmann, M., and V. Hild. 1980. Effect of indoleacetic acid, abscisic acid, root tips and coleoptile tips on growth and curvature of maize roots. *Planta* 150: 32-36.
- Slocum, R.D., and S.J. Roux. 1983. Cellular and subcellular localization of calcium in gravistimulated coleoptiles and its possible significance in the establishment of tropic curvature. *Planta* 157: 481-492.
- Tepfer, M., and R.E. Cleland. 1979. A comparison of acid-induced cell wall loosening in *Valonia ventriculosa* and in oat coleoptiles. *Plant Physiology* 63: 898-902.
- Vesper, M.J. 1985. Use of a pH-response curve for growth to predict apparent wall pH in elongating segments of maize coleoptiles and sunflower hypocotyls. *Planta* 166: 96-104.
- Wright, L.Z., and D.L. Rayle. 1982. Inhibition of shoot geotropism by neutral buffers. *Plant Physiology* 69: 278-279.
- Wright, L.Z., and D.L. Rayle. 1983. Evidence for a relationship between H<sup>+</sup> excretion and auxin in shoot gravitropism. *Plant Physiology* 72: 99-104.



## GRAVITY AND ANIMAL EMBRYOS

Lynn M. Wiley  
 University of California  
 Davis, CA 95616

What is the likelihood that mammalian development might be affected by conditions encountered during space flight?

After more than 4,500 "rat hours" in space, there has been only one attempt (Cosmos 1129) at mating with an apparent absence of fertilization, implantation and subsequent development to parturition. However, segments of the cycle have occurred successfully, at a gross level (Final Reports of U.S. Monkey and Rat Experiments flown on the Soviet Satellite Cosmos 1514. R.C. Mains and E. W. Gomersall, eds. NASA Technical Memorandum 88223. p. 189, 1986). Specifically, later gestation and parturition in the rat proceeded during Cosmos 1167. However, on an earlier flight (Cosmos 1129) copulation and subsequent events did not proceed in the rat. It is not possible, unfortunately, to conclude whether the observed reproductive failure resulted from perturbations of biological process per se or for trivial reasons such as improper photoperiod.

Subsequent ground tests at NASA/Ames (1981; NASA-N81-32852) were performed to determine whether the following flight-related factors might have contributed towards the observed reproductive failure on Cosmos 1129:

- a) effects of re-entry stresses on timed pregnant rats
- b) effects of launch stresses on the male rat mating ability
- c) effects of full flight simulation on viable pregnancies
- d) Soviet paste diet
- e) launch vibration, noise and acceleration
- f) group housing in a confined volume
- g) competition for limited food
- h) restricted illumination and airflow
- i) re-entry shock and acceleration
- j) post-flight handling and isolation

None of these factors was able to cause all animals to fail to establish and maintain pregnancy to term. Furthermore, there were no significant differences in number of live fetuses and births or in adrenal weight ratios between the group exposed to launch and re-entry stresses, to the animal husbandry aspects of the flight conditions, and the control group. NASA's conclusion was that the failure of some flight- and control females to bear young was probably not solely due to the stresses of launch and re-entry.

These observations are consistent with the hypotheses that i) in a small mammal, the endocrinologic, cellular and molecular mechanisms comprising embryonic development after implantation, fetal development and parturition may occur in space, and ii) events preceding an established pregnancy might be impaired in space. To examine the second hypothesis, one can ask the following two experimental questions:

1. Is the hypothesized developmental impairment direct and/or indirect; i.e., is the impairment a result of direct effects of the space environment on

the gametes and the embryo and/or a result of indirect effects stemming from the maternal and/or paternal response(s) to the space environment?

2. Which developmental process(es) is/are impaired; i.e., are female factors, male factors, or a combination of male and female factors involved? Female factors might include oogenesis, ovulation, gamete transport, fertilization, embryo transport to the uterus, implantation and luteal function. Male factors might include spermatogenesis, sperm transport and ejaculation. Combined factors might include copulation together with any of the other factors named above.

Proposed experiment: examine in vitro and in vivo development in parallel in space.

As a starting point, we could conduct this experiment using two groups of female mice that have been mated on the ground 24 h prior to a 5-day flight. During the flight, one group of mice could be sacrificed when their embryos were at the 2-cell stage of development and these embryos cultured until ground control parallel cultures of embryos had attained the blastocyst stage. Mice from the remaining group could be sacrificed at various timepoints to compare the developmental progress of their embryos with that of the embryos developing in vitro in flight and on the ground and in vivo on the ground. The advantages of this strategy are:

1. we eliminate behavioral factors related to copulation, increasing the likelihood of obtaining some useful information from the experiment.
2. we circumvent the need for in vitro fertilization and embryo transfer.
3. we take advantage of the fact that only preimplantation embryos of the mouse can be cultured throughout cleavage.
4. mouse embryonic development from the 2-cell stage to implantation normally takes 3.5 days; therefore a 5-day flight should be long enough for preimplantation development to implantation to take place, even if it is delayed somewhat by flight conditions.

Selecting experimental parameters for evaluating preimplantation development: 1) cleavage rate, 2) embryo cell number and 3) blastocyst formation accompanied by inner cell mass/trophectoderm differentiation.

Preimplantation development prepares the embryo for two events, embryogenesis and implantation. Each event is mediated by two different cell lineages, the inner cell mass and the trophectoderm, respectively. These two cell types are normally present by the blastocyst stage when the embryo finds itself within the uterus. To form both cell types requires that the embryo sustain a cleavage rate that will be fast enough to produce the minimum number of cells required for both cell types to develop adequately by the blastocyst stage. If embryo cell number is less than 16 when the two cell types begin to differentiate, then not enough cells may be available to form an inner cell mass and only trophectoderm will form or an inner cell mass of insufficient cell number might be formed. An inner cell mass that is missing or of insufficient cell number results in an implantation that is resorbed.

This is the rationale for selecting these 3 parameters for assessing the normalcy of preimplantation development in space flight. In addition, these parameters have been used traditionally for assessing preimplantation development and are easy to follow and quantitate and require only a dissection microscope for scoring.

## Epigenetic influences on preimplantation development.

Many non-genetic influences from the environment can be reflected by these parameters. One is the concentrations of ions in the extraembryonic milieu--potassium and sodium specifically. Low levels of potassium will accelerate the onset of blastocyst formation and may cause it to begin before the embryo has 16 cells. Since space flight alters the ionic composition of serum--and perhaps also of oviductal fluid, abnormal ion concentrations might be a factor during preimplantation development during space flight.

Other epigenetic influences consist of cytoplasmic asymmetries. For example, the blastomere of the 2-cell embryo that inherits the remnant of the sperm tail will contribute more of its progeny cells to the inner cell mass than will its sister blastomere (Bennett J. 1982. J Cell Biol 163a).

Yet other influences are provided by extra-cytoplasmic, environmental asymmetries, the best-known one being asymmetric cell-cell contacts. At the 8-cell stage, asymmetric cell-cell contacts are established as a result of 'compaction' when the formerly spherical blastomeres flatten against one another. The blastomeres in the post-compaction embryo have basolateral surfaces that are apposed against adjacent blastomeres and apical surfaces that face the oviductal fluid. Consequently, the blastomeres exhibit an apical-basal axis of polarity. When such a polar blastomere divides so that one daughter cell inherits its apical half and the other daughter cell inherits its basal half (differential cell division), the apical daughter gives rise to trophectoderm while its basal sibling gives rise to inner cell mass. This is how the two cell lineages, inner cell mass and trophectoderm, are formed (review Johnson MH and Pratt HPM 1983 in Time, Space and Pattern in Embryonic Development, Alan R. Liss, Inc. NY pp 287-312). Processes that impair the development of blastomere polarity--like the impairment of the cell shape changes and the increase in cell-cell adhesiveness that accompany compaction--will reduce the incidence of differential divisions and it is only differential divisions that will produce inner cell mass. (When the apical and basal cytoplasm of a parent polar blastomere are divided equally between the two daughters--conservative division--both daughters give rise to trophectoderm).

Aside from asymmetric cell-cell contacts, extracellular d.c. electric fields can also influence the developmental polarity of isolated blastomeres and their incidence of differential cell divisions. There is no information that indicates whether other physical environmental asymmetries such as an asymmetric gravity vector (such as 1 g)--or the lack thereof--can influence blastomere polarity and the likelihood of differential cell divisions.

## Hardware considerations for accomodating preimplantation development in vitro in space.

In the conventional laboratory, embryos are obtained by flushing excised oviducts with a syringe of culture medium attached to a 30 g needle, with the aid of a dissection microscope (200X). Small numbers of embryos (about 20 2-cell embryos) are obtained per mouse so that several mice must be on hand to provide the 100 or so 2-cell embryos that would be necessary for one experiment envisioned by Dr. D. Wolgemuth and myself.

All embryo manipulations are performed with the aid of dissection microscopes (200X), including scoring for cleavage rate and incidence of blastocyst formation and embryo cell number. Manipulations include

transferring embryos from one medium to another during oviduct flushing and pooling prior to establishing cultures and fixation for morphology or for obtaining embryo cell numbers. Embryos are normally handled by mouth pipetting while they are submerged in cultured medium and cannot be allowed to contact an air-fluid interface.

Embryo temperature must be maintained between 35°C and 37°C for reproducibility and their culture medium is normally bicarbonate-based so that a carbon dioxide incubator is necessary. All manipulations, from excising oviducts from the female to establishing embryo culture, must be done using sterile technique.

It normally takes about a year before a person has acquired sufficient technical skill and judgement about embryo morphology to reliably flush oviducts and culture embryos with any consistency. Herein lies a major concern: handling these embryos on the ground--much less in space--can present a formidable challenge. I think that flushing the oviducts might prove the most frustrating aspect of this experiment. Using frozen embryos based on present embryo-freezing technology will not substitute for non-frozen embryos. ... Out of curiosity, with respect to frozen embryos, how does freezing/thawing react to microgravity?

## HUMAN FACTORS ISSUES IN PERFORMING LIFE SCIENCE EXPERIMENTS IN A 0-G ENVIRONMENT

Wayne Gonzalez  
Lockheed Missiles & Space Co.  
Bioastronautics Division  
Sunnyvale, CA

### SPACELAB AND SPACE STATION FREEDOM

The Spacelab pressurized module is about 13 feet in diameter and 23 feet long, counting both the core and experimental segments. Because of the volume occupied by equipment racks the remaining central cross-section for crewmember movement is about 7 feet square, although it is narrowed near the ceiling. It provides a shirt-sleeve, sea-level pressure environment. Because of orbiter center-of-gravity requirements, access to the module is via a tunnel from the orbiter middeck.

The Space Station Freedom US Lab module will be approximately 14 feet in diameter and 44 feet in length. Allowing for racks, the remaining central open cross-section also will be about 7 feet square. An important contrast with Spacelab is in length and the full utilization of 4 rows of equipment and storage racks, to form the wall, floor and ceiling. The environment aboard Space Station Freedom also will be shirt-sleeve with sea-level pressure.

### CONTAMINATION CONCERNS

The requirements in Freedom for cabin air contamination control are more strict than in Spacelab. Unlike Spacelab, which can be returned to earth in 14 days to be cleaned up, aired-out, and deodorized, Freedom will remain in orbit for 30 years. For this reason, Class 100K cabin air requirements are imposed, comparable to many clean room environments. For example, it is doubtful that Velcro can be used in Freedom because of the small breakage particulate matter it generates. This simple fact, alone, is already causing consternation among astronauts and human factors engineers.

While requirements are more strict for Freedom than for Spacelab, Life Science studies requiring active manipulations of any type must be performed in a carefully controlled environment, such as a glovebox. Lockheed developed and delivered to NASA the General Purpose Workstation to provide the glovebox environment for use onboard Spacelab. As the Life Sciences contractor for the Freedom US Lab, Lockheed also will develop and deliver to NASA the Life Sciences Glovebox with other Life Science support facilities & equipment, as well as the Maintenance Workstation which provides containment capabilities as needed. The required use of these facilities imposes restrictions not generally realized in an earth environment. For example, where a science laboratory open workbench or laminar-flow curtain workbench might be utilized on earth, a completely contained glovebox with full air-scrubbing capabilities must be utilized in space. The glovebox will restrict visibility, will have annoyingly limited volume and freedom of movement, and utilize power and consumables as needed to keep the glovebox functioning. Additionally, video and still cameras are typically utilized along with corresponding requirements for adequate illumination and desirable

real-time communication to earth. There may be concurrent needs to utilize data entry and/or processing systems.

A corresponding requirement, especially for the long-term multiple-use Life Science Glovebox onboard Freedom, is for decontamination. The glovebox and apparatus must be decontaminated adequately to allow the removal of one set of specimens and apparatus and entry of a different set of experimental specimens and equipment. The complex merger of cost effective design and decontamination and requirements is still underway. There must, of course, be tradeoffs with other requirements such as structure and weight, design commonality, and productive time considerations. It is estimated that a half-hour may be needed to achieve required clean levels before changing out the glovebox.

These described functions and activities combine to represent a heavy burden on available resources. Utility and other consumable resources are a precious commodity in space. Freedom resupply flights will be very costly and must be limited. Utilities such as power must be allocated and budgeted to equitably support the broad spectrum of experiments and international interests onboard Freedom, especially. The same picture applies to Spacelab but perhaps not as severely.

Astronaut time is also a crucial resource. Working with a glovebox increases demands on strength, dexterity, and general staying power. Thus, we expect slower task performance and a sooner onset of fatigue than would occur outside the glovebox. Contamination concerns impose significant demands on both physical and human resources. Because of the associated requirement to manage resources, crew activity schedules must be developed and they must be closely followed.

#### MICROGRAVITY

The concept of zero or micro gravity is familiar to everyone. A closer look at this phenomenon, however, with respect to its affects on the dynamics of operating in this environment is of importance to adequate human factors engineering. Conceptually, there is a "fine-line" of true 0-g at the center of mass of the object in orbit, corresponding to the orbital path. Locations above or below that line will experience increasing degrees of microgravity (towards or away from earth) with increasing distance from the center. Practically speaking, this affect is negligible, although it may be of concern to some scientific experiments.

All unrestrained objects will "drift" in the direction of microgravity. Left untethered or otherwise restrained, small objects, especially, can drift away unnoticed, to be lost or perhaps to cause damage. Many small items, in fact, were lost onboard Skylab. Microgravity drift is compounded by the effects of air flow, especially with small items. Many items were eventually found on filters of air conditioning intake screens. It is relevant to note that gloveboxes include directed airflow.

Specifically, microgravity forces require that every object must be restrained in order to stay in one place.

On earth the luxury of space enables leaving certain equipment on the table for "next time." The workbench is reasonably large and stowage of auxilliary items is provided nearby. Any new items brought to the table can be brought in bulk and setdown for setup. Something forgotten can be brought later.

In space, if there is any possibility of contamination due to nominal or accidental events, "table top" work must be performed within a glovebox for the safety of the crew and of specimens.

The planned Freedom Life Science Glovebox is about 40" wide, 30" deep, and 26" high.

The Spacelab General Purpose Workstation is about 28" wide, 23" deep, and 26" high.

Strict control of all equipment is crucial. On Skylab, some experiments were abandoned because all needed items could not be found. On Freedom an Inventory Management System will track every item of equipment. But in some form, it must be told what is being taken where by whom. That will take time. Means to automate this function are being investigated.

When two or more items are brought to the workplace/glovebox problems occur. Problems are compounded if the only way into the glovebox is via an airlock or similar passage. Envision one item in each hand. With one hand, therefore, the crewmember must perform the steps required to pass the first item through the airlock and into the glovebox and restrain it, therein. While so doing, he must restrain himself and retain safe control of the second item. Obviously, there are many variations on this scenario with alternative solutions but the point is at least partially made.

Without belaboring the issue it is important to recognize the corresponding requirements for item restraint during the performance of activities in or out of a glovebox. A quick routine movement, for example, during a dissection procedure could inadvertently leave a scalpel floating freely within a glovebox. Anything let loose by a bump, careless slip of a grasp, or a similar impetus represents a real hazard because in 0-g there is a strong interial tendency for things to keep moving, bouncing from surface to surface.

While good analysis and planning will lead to as many appropriate design provisions as possible, many will necessarily be "best guess." Also, it is expected that good habit-forming training in 1-g for a 0-g environment will be difficult.

## BIOMECHANICS

Some of the effects on astronauts performance due to microgravity were introduced above. More specifically, crewmembers also must be restrained in order to stay in one place. "Staying in one place" is enough for most objects; it is not enough for the crewmember. People also must retain an orientation which is functional with respect to the task at hand. A 1-g orientation is desirable and in some tasks, essential, to make immediate sense of them. If forces must be applied the restraint scheme must provide the needed compensating support/restraint. Typically, therefore, a simple tether is

inadequate. Also, typically, people must actively participate (flex muscles) to retain a desired position. This is achieved by use of the hands and/or fingers, the feet and/or toes, or virtually any part or parts of the body which can be used to wedge or grasp a secure hold on whatever is available to do so.

For example, if microgravity pulls crewmember away from a rack face (i.e., towards his heels) the force tends to remove his feet from the footloops. Thus, the crewmember will drift back and/or allow his feet to rotate upward, or the foot and toes must be lifted to retain their position. This unusual muscle flexion is fatiguing. To relieve this effort, one or both hands may be used to grasp a hand rail. If the hands are otherwise occupied, or should be otherwise occupied, the dynamics are at least distracting. Delay or error in the performance of a sensitive task could occur. In the case of a crewmember utilizing a glovebox, he might press against the hard edges of the gloveports as a means of restraint. This action could alternately aid or hinder the task at hand.

It is expected that an available foot restraint system on Freedom will provide a positive "grip" so that active foot and/or toe flexion is not needed for retention. Another area of important consideration is the adaptability and location of foot restraints. For example, the placement for a large person applying a pushing force within a glovebox can be reasonably low and close to the workstation face, in contrast to the higher and farther out placement needed for a smaller and weaker person. The anthropometric range for design of Freedom is from the 5th percentile Japanese female to the 95th percentile American male (extrapolated to the year 2000).

Another area of experience reported by astronauts is the awkwardness of performing certain tasks in the absence of the "reference force" provided by gravity. For example, typing is typically performed with the arms, hands and fingers in contact with nothing except the pressed keys during active typing strokes. On earth, gravity holds the arms down and muscles learn to flex from the 1-g reference point to locate and press the correct keyboards keys. The coordination and/or dexterity needed for the entire limb positioning, search and find and press action is learned, utilizing the opposing forces of muscles and 1-g on earth. In space the gravity reference is lost and holding the hands and fingers in place at the correct height, the proper location, exerting the appropriate forces, etc., are made more difficult by the loss of gravity. We understand that the use of a firm reference point, such as a bar against which to press with the heel of the hand, is a definite aid.

We have not had the opportunity to conduct adequate studies, but there are indications, at least, that appropriate measures should be made to support the performance of other sensitive tasks, such as specimen dissection. Such provisions may need to be optional and/or variable to accommodate different people and different tasks. With reference to the previously described issues in performing Life Sciences tasks in space, however, this concern adds another dimension to the human factors concerns.

## SUMMARY

Sampling the Human Factors Engineering concerns, with reference to the performance of Life Science in space, provides an indication of the nature of



some problems facing mission scientists. An accurate conception of these issues is needed in order to plan and design for effective missions. It is believed that only a well coordinated team effort of the scientific user community and program system designers can lead to missions successes.

NASA, Marshall Space Flight Center, has assigned Bill Ramage as responsible for integrating Customer Utilization requirements for the Space Station Freedom program. Supporting Ramage is Harvey Willenberg, Boeing Aerospace, (205) 544-8173, and William Cutler, Lockheed Missiles & Space Co. (408) 756-5922.

DO THE DESIGN CONCEPTS USED FOR THE SPACE FLIGHT HARDWARE  
DIRECTLY AFFECT CELL STRUCTURE AND/OR CELL FUNCTION  
GROUND BASED SIMULATIONS

David K. Chapman  
University of Pennsylvania  
Philadelphia, PA 19104-6018

ABSTRACT

The use of clinostats and centrifuges to explore the hypogravity range between zero and 1 g is described. Different types of clinostat configurations and clinostat-centrifuge combinations are compared. Some examples selected from the literature and current research in gravitational physiology are presented to show plant responses in the simulated hypogravity region of the g-parameter ( $0 < g < 1$ ). The validation of clinostat simulation is discussed. Examples in which flight data can be compared to clinostat data are presented. The data from 3 different laboratories using 3 different plant species indicate that clinostat simulation in some cases were qualitatively similar to flight data, but that in all cases were quantitatively different. The need to conduct additional tests in weightlessness is emphasized.

Introduction

Several methods to either simulate the weightlessness state or to produce short periods of weightlessness have been used in ground based simulations. They include bed rest studies, tail suspension tests, water immersion, clinostats and free fall using parabolic flight maneuvers and drop towers. Many biological studies require that g be made an experimental variable. For many of these studies the use of clinostats and centrifuges have been used to explore the hypogravity g-range between zero and 1 g.

Most of these experiments fall into two major categories: (a) The phenomenon to be studied is believed to be quantitatively dependent on a g-force and the investigator wants to define the g-function of his test subject's response to different g-levels in the hypogravity region: (b) The test system responds in a similar way to gravity and some other factor of special interest and to measure the latter it may seem necessary to decouple the response to gravity from the response to the other factor.

Clinostat and Clinostat-Centrifuge Configurations

Clinostats have been used to simulate the weightless condition for about a century (Brown, 1979). They are rotating machines that rotate the test subject slowly around some axis with respect to the coordinates of the subject (usually the longitudinal axis). The simulation effect is achieved by rotating the subject in a manner such the axis of rotation is normal to the earth's g-force vector. As the clinostat rotates the earth's g-force moves around the axis once each revolution and if summed the effect is assumed to be zero. The rotation rate should be fast enough to achieve gravity compensation, but slow enough to prevent significant centripetal forces. Acceptable levels of centripetal force vary, depending on the g-

force required to elicit a response. For some systems a centripetal force of  $10^{-4}$  g can be detected and in others a level of  $10^{-2}$  g can be tolerated. The rates most frequently used are between 1 - 10 rpm.

The axis of rotation may be horizontal or less than 90 degrees from the plumb line. The subjects longitudinal axis may be in the plane of its rotation or it may be normal to that plane. The subject may be rotated on two or even on three (usually orthogonal) axes simultaneously. Several of the many possible modes of clinostat function which have been used in plant physiological experiments are shown in Table I and Figure 1.

There are special applications that employ rapid rotation (ca. 50 - 200 rpm) and are referred to as "fast clinostats" (Briegleb, 1967). They usually are used to suspend cell particles within the cell. One of the requirements is to locate the cell in the center of rotation. If the cell moves off center by a few millimeters it will experience centripetal forces which may be significant. For example if the speed is 50 rpm the test subject will have to be retained within a radius of 3.6 mm to prevent it from experiencing centripetal forces greater than  $10^{-2}$  g.

The most common use of a clinostat has been to achieve gravity compensation with the axis of the clinostat rotation in the horizontal position. However if the experimenter wishes to explore the entire hypogravity range between zero and 1 g the axial g-force component must be altered. This can be accomplished by either placing the clinostat on an angle from the horizontal or by applying an axially directed centripetal g-force. If the clinostat is placed on an angle, the axial component of earth's g-force depends on the cosine of the angle of inclination that departs from the plumb line (Brown and Chapman, 1977). The use of a single axis clinostat and a centrifuge can be employed to create a two axis clinostat with one of the axes providing gravity compensation with a horizontal clinostat and the other applying a centripetal acceleration in the horizontal direction. Both configurations are depicted in Figure 2.

#### Hypocoytl Nutation in Simulated Hypogravity

A number of investigators have employed clinostats to simulate hypogravity, but only a few have explored the entire range between simulated zero and 1 g. The first reported use of a centrifuge and horizontal clinostat to investigate levels above zero g was in 1961 by Finn and Brown (1961). A more recent study to characterize hypocoytl nutation of sunflower seedlings in the hypogravity region ( $0 < g < 1$ ) rotated them on orthogonal axes using a horizontal clinostat to provide gravity compensation and a centrifuge to apply centripetal acceleration along the plants longitudinal axis (Chapman et al, 1980). The configuration used is depicted in Figure 2B.

The results shown in Figure 3 indicate that below 1 g both the period and amplitude changed markedly. There was a 35% reduction in the period of nutation and a 80% reduction of the amplitude at simulated 0g. Neither the period or amplitude extrapolated to the origin.

These ground based simulation tests which were conducted to characterize circumnutation of sunflower hypocoytles provided useful background information for an experiment that was conducted during the Spacelab-1 mission in 1983 to determine the gravity requirement for circumnutation. These tests indicated that

gravity did influence circumnutation and that its mechanism could not be entirely endogenous, but on the other hand, the fact that at simulated zero g it did not completely damp out did not support the role of gravity as the exclusive driving force for the oscillations.

### Validation of Clinostat Simulations

The least g-force condition, attainable only in space, is microgravity, essentially "zero g" or weightlessness. Gravity compensation, achieved by use of horizontal clinostats is assumed to mimic zero g. In order to test this theory the effects of weightlessness and of clinostats must be compared in adequately controlled experiments of statistically competent design.

For higher plants, tissue cultures, microorganisms, and small animals the horizontal clinostat has been employed with the usually tacit assumption that its simulation of hypogravity (most often zero g) is at least an excellent approximation of the true environmental condition it putatively imitates. Obviously that assumption ought to be tested for, if it cannot be validated, an unfortunately large number of experimental findings based on tests with clinostatted biological material necessarily must be reevaluated (Brown et al, 1976).

Direct tests of the validity of clinostat simulations of course were impossible until scientists could attain experimental access to a (nearly) weightless environment achievable only in space. In recognition of the importance of knowing the validity of hypogravity simulations NASA's first orbital mission designed exclusively for its effort in space related gravitational biology (Saunders, 1971) included two major experiments with a large number of functional objectives that would become biologists' first direct test of clinostat simulation validity.

The experiments, flown on Biosatellites I and II, were designed to acquire quantitative data of known precision and, for each of the biological processes tested, results obtained from space flight were compared with appropriate ground controls. One growth process that had been studied extensively on earth and on earth bound clinostats was the epinastic response (altered position of lateral plant organs such as leaves and secondary roots). It provided the best data for the desired tests of agreement between results from the clinostat environment and from true microgravity.

It is in principle nearly impossible to "prove a negative" and if, for one or a few phenomena, results from space flight and results from clinostatting are in statistical agreement, we can only conclude tentatively that there may be no "real" difference-- a conclusion strongly encouraged by our wishful thinking. But if the differences are large (unquestionably significant), that would be a serious blow to our tentative conclusion of equivalency and would demonstrate that clinostat simulation would not always be dependable without verification by space flight tests for each new phenomenon to be studied.

Epinastic responses of wheat roots and of pepper plant leaves were not the same on clinostats and in microgravity (Brown et al, 1976; Brown et al, 1974; Lyon, 1968; Johnson and Tibbitts, 1968). The data in Table II indicate the differences between space flight and clinostat data for the pepper plant. The initial angles at launch were not significantly different. The initial rate of change of the petiole angles

(degrees/hr) was significantly different,  $P < 0.001$ . The final angles that were attained were also significantly different at the 1% level or beyond.

The data in Table III indicate that while the epinastic responses for wheat roots were qualitatively similar they were quantitatively different. The difference between the clinostat and microgravity data were significantly different at the 1% level. In both cases the experimenters chose to discount the importance of statistical analyses of Biosatellite II results--presumably because the data showed effects of clinostatting were less extreme than those of space flight; a possible consequence of only small deficiency in the clinostat's ability to simulate true weightlessness (Lyon, 1968; Johnson and Tibbitts, 1968).

Sixteen years after the flight of Biosatellite II NASA's Spacelab-1 mission provided data that permitted definitive quantitative comparisons for parameters of sunflower circumnutation on earth based clinostats and in microgravity (Brown and Chapman, 1984). The data in Table IV (adapted from Brown and Chapman, 1984) show that when compared with plant behavior at 1 g circumnutation was less vigorous on clinostats than during space flight. The changes were large but especially significant was the difference between the effect of space flight and the effect of clinostatting; the clinostat environment suppressed circumnutation much more than did microgravity, a result that reasonably could not be attributed to clinostat imperfection. One could not criticize the microgravity condition as a poor simulation of the clinostat environment!

It seems evident that validation of clinostat simulations, especially for research in plant biology, has warranted a high scientific priority for about twenty years. However, the number of phenomena studied and the number of flights on which such test were possible have been discouragingly few. It appears that this important topic remains in the category of NASA science's unfinished business.

#### REFERENCES

- Briegleb, W. 1967. Ein Modell zur Schwerelosigkeits-Simulation an Mikroorganismen. *Naturwissenschaften* 54:167.
- Brown, A.H., D.K. Chapman and S.W.W. Liu. 1974. A comparison of leaf epinasty induced by weightlessness or by clinostat rotation. *Bioscience* 24:518-520.
- Brown, A.H., A.O. Dahl and D.K. Chapman. 1976. Limitation on the use of the horizontal clinostat as a gravity compensator. *Plant Physiol.* 58:127-130.
- Brown, A.H. and D.K. Chapman. 1977. Nutations of sunflower seedlings on tilted clinostats. *COSPAR Life Sciences and Space Research* 15: 279:283.
- Brown, A.H. 1979. Research opportunities and limitations of protracted hypogravity simulation for plant gravitational physiology. *The Physiologist* 22: (No. 6) Supplement 15-18.
- Brown, A.H. and D.K. Chapman. 1984. Circumnutation observed without a significant gravitational force in space flight. *Science* 225:230-232.

- Chapman, D.K., A.L. Venditti and A.H. Brown. 1980. Gravity functions of circumnutation by hypocotyls of Helianthus annuus in simulated hypogravity. *Plant Physiol.* 65:533-536.
- Finn, J.C. Jr., and O.D.R. Brown. 1961. Plagiotropism in petioles of Xanthium . *Plant Physiol.* 36: (supp.) xxi.
- Johnson, S.P. and T.W. Tibbitts. 1968. The liminal angle of a plagiotropic organ under weightlessness. *Bioscience* 18:655-661.
- Lyon, C.J. 1968. Wheat seedling growth in the absence of gravitational force. *Plant Physiol.* 43:1002-1007.
- Saunders, J.F. (Ed.) 1971. *The Experiments of Biosatellite II*. NASA SP-204, Sci. Tech. Info. Office, Washington, DC.

Table I. CLINOSTAT CONFIGURATIONS

TYPE	NUMBER OF AXES	COINCIDENCE OF A ROTATIONAL AXIS WITH A PLANT AXIS	VECTOR DIRECTION OF FORCE RELATIVE TO THE PLANT AXIS	AXIAL g-FORCE ON PLANT	EXAMPLE
A-1	1	COINCIDENT	VARIABLE	$0 < g < 1$	VARIABLE ANGLE CLINOSTAT
A-2	1	COINCIDENT	TRANSVERSE	$g = 0$	CONVENTIONAL 90° (HORIZONTAL) CLINOSTAT
A-3	1	COINCIDENT	PARALLEL	$g=1$	VERTICAL ROTATION
B-1	1	NOT COINCIDENT BUT PARALLEL	TRANSVERSE	$g = 0$	PERIPHERAL ARRAY
C-1	1	NOT COINCIDENT	CHANGES CONTINUOUSLY	$g = 0$	TUMBLING
D-1	2	COINCIDENT NON-ORTHOGONAL	VARIABLE	$g \geq 0$	CLINOSTAT AND CENTRIFUGE

TABLE II. Epinastic response to altered gravity  
S P Johnson and T W Tibbitts (1968)

Initial petiole angles (Degrees)<sup>a</sup>

Flight Data 153.8 ± 3.6

Clinostat Data 158.7 ± 3.7

Difference 4.9 ± 5.2

Probability of difference occurring merely by chance, P = 0.36<sup>b</sup>

Initial rate of change of petiole angles (Degrees/Hr)<sup>a</sup>

Flight Data 3.04 ± 0.10

Clinostat Data 4.24 ± 0.13

Difference 1.2 ± 0.16

Probability of difference occurring merely by chance, P ≤ 0.001

Final petiole angles (Degrees curvature after 20 hr in orbit)<sup>a</sup>

Flight Data 103.6 ± 0.7

Clinostat Data 113.0 ± 0.6

Difference 9.4 ± 0.9

Probability of difference occurring merely by chance, P ≤ 0.001

<sup>a</sup>Data are expressed as mean ± Standard Error

<sup>b</sup>Not a significant difference



TABLE III. Epinastic response of wheat lateral roots to altered gravity. (Data of C J Lyon, 1968)

<u>Condition</u>	<u>n</u>	<u>Liminal Angle (Degrees)</u>	<u>Percent change from 1 g controls</u>
Microgravity	96	99.6 ± 1.4	59.6 ± 1.61%
Clinostat	97	94.2 ± 1.5	51.0 ± 1.70%
1 g Controls	127	62.4 ± 0.8	

Conclusion: Probability that plants on clinostat and those in microgravity were different only by chance,  $P \leq 0.009$

TABLE IV. First quantitative measurements of parameters of sunflower hypocotyl circumnutation on clinostats and microgravity, (Data from Spacelab-1 experiment A H Brown)

	On Clinostat <sup>a</sup>	In Microgravity <sup>a</sup>
Number of cycles observed in 13 plants	50	121
Amplitude of circumnutation oscillation (mm)	1.66 ± 0.16 <sup>b</sup>	2.77 ± 0.13 <sup>b</sup>
Period of circumnutational oscillation (min)	78.47 ± 2.55 <sup>c</sup>	87.60 ± 2.58 <sup>c</sup>

<sup>a</sup>Data are expressed as mean ± Standard Error

<sup>b</sup>Probability of difference occurring merely by chance,  $P \leq 0.00006$

<sup>c</sup>Probability of difference occurring merely by chance,  $P \leq 0.012$

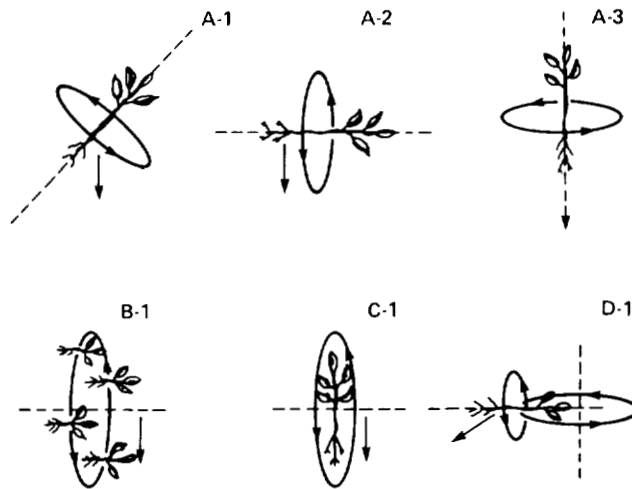

Figure 1 Clinostat configurations that have been used for research in gravitational plant physiology.

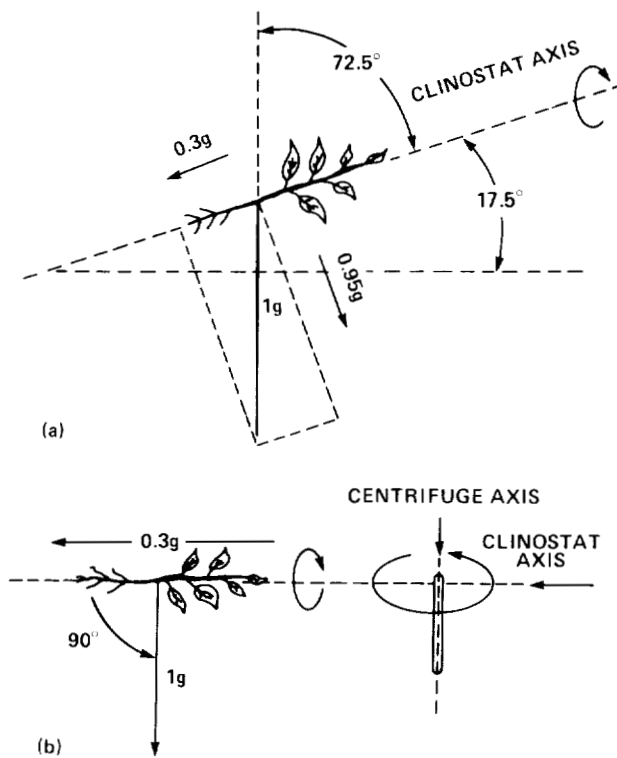

Figure 2 Force diagram for equivalent conditions of clinostatting. (Modified from Brown, A.H. 1979. *The Physiologist* 22 (No. 6) Supplement 15-18).

- A. (Above) Type A-1; Axial component of earth's 1 g also imposes 0.3 g in axial direction. Force magnitude depends on cosine of angle of inclination.
- B. (Below) Type D-1; Centripetal force of 0.3 g imposed in axial direction. Force magnitude depends on rotation rate and radius.

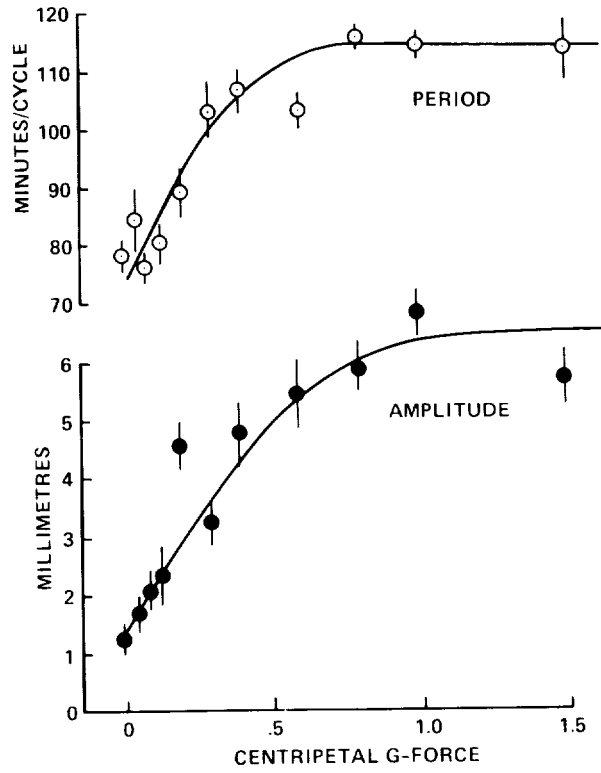

Figure 3 Amplitude and period of circumnutation over a range of axial forces between 0 and 1.5 g achieved by rotation on 2 axes. Earth's gravity was compensated as in Figure 2B.

## MODEL SYSTEM STUDIES WITH A PHASE SEPARATED MEMBRANE BIOREACTOR

G.R. Petersen and P.K. Seshan  
Jet Propulsion Laboratory  
4800 Oak Grove Drive  
Pasadena, CA 91109

E.H. Dunlop  
Department of Chemical Engineering  
Colorado State University  
Fort Collins, CO 80523

### ABSTRACT

The operation and evaluation of a bioreactor designed for high intensity oxygen transfer in a microgravity environment is described. The reactor itself consists of a zero headspace liquid phase separated from the air supply by a long length of silicone rubber tubing through which the oxygen diffuses in and the carbon dioxide diffuses out. Mass transfer studies show that the oxygen is film diffusion controlled both externally and internally to the tubing and not by diffusion across the tube walls. Methods of upgrading the design to eliminate these resistances are proposed. Cell growth was obtained in the fermenter using *Saccharomyces cerevisiae* showing that this concept is capable of sustaining cell growth in the terrestrial simulation.

### INTRODUCTION

The use of a bioreactor as a fermenter in Controlled Ecological Life Support Systems (CELSS) will likely occur in the food production or waste processing subsystems. It is anticipated that a design for a fermenter for an operational CELSS will be developed from models flown and tested on STS missions.

#### Probable areas of use

There are three possible places a CELSS-type bioreactor could be used:

i. As redundancy or backup for the conventional food production systems that would be available in space. It is clear that several systems could be developed, probably using plants and/or animals. However there is always the problem of catastrophic crop failure and if there is not enough stored food and it would be necessary to activate emergency rations of food. One possible source of this is microbial food which can be made available in two or three days. We have done preliminary studies that show that in reasonable sized fermenters it is possible to produce adequate quantities of edible types of biomass, for example yeast, that can be processed into the necessary food components.

ii. As supplements to conventional food production. The limiting amino acids for human nutrition are tryptophan and lysine. One of the deficiencies

in human foods such as wheat and similar materials is very easily satisfied by microbial sources. Many bacteria, and some yeasts, could provide the necessary amounts of lysine, methionine and tryptophan. This is just one example of a supplement and others may be possible. Also an analysis of human food balances reveals that even when using wheat and high quality foods humans are still short of carbohydrate. It is possible that it will always be necessary to have some calories from microbial carbohydrates.

iii. The area that will probably have first application for the bioreactor is the production of valuable commodities (in this case, food) from inedible plant waste. It is a consistent observation for all plants that about 50% of biomass is inedible. Of the inedible biomass, about 40% is comprised of cellulose and about 20-30% is found in hemicellulose (pentose sugars). These two components are readily separated with mild hydrolysis and fractionation methods. The further hydrolysis of these components into monosaccharides suitable for direct use or fermentation by microorganisms provides additional food sources for CELSS food production subsystems.

#### APPARATUS AND METHODS

The main problem with carrying out fermentations in microgravity is of course that the bubbles will not rise in the fermenter thus preventing gas - liquid disengagement (1). One reasonable solution is to avoid the need to solve the separation problem by not having a gas phase to disengage. The apparatus is designed to explore this concept for high-rate oxygen-transfer intensive microbial growth in a CELSS environment.

The gas and liquid phases are kept separate when the reactor contains about 10% by volume of silicone tubing in a zero-headspace fermentation configuration and passing the gas (air or oxygen) through the inside of the tubes. Oxygen and carbon dioxide are highly permeable to silicone rubber and diffuse rapidly through it. It is also possible to have liquid silicones saturated with oxygen passing through the tubes to act as oxygen carriers. Carbon dioxide can be readily removed from the off-gases by adsorption in a sink such as monoethanolamine. A potentially attractive alternative to a fixed CO<sub>2</sub> sink is reversible adsorption by redox-switched absorbers such as substituted metalloenes and quinones (2).

Such a system is essentially gravity-independent and can be readily examined under terrestrial conditions.

The terrestrial model tested was constructed from plexiglass in the form of a cylinder containing a total of 8.7 liters volume. The working volume was about 7.7 liters, the other liter being occupied by tubing and support frames. Thus 88% was available for culture.

150 feet of silicone tubing was wound round a support frame. The tubing had an internal diameter of 0.104 inches and an external diameter of 0.192 inches.

Stirring was provided to the center of the liquid by a marine impeller revolving at 200-400 revolutions per minute. Air flow to the inside of the tube could be varied by a mass flow controller from 2.5 to 20 liter per minute gas flow at an applied pressure of between 3 and 10 psig.

A 1.5% inoculum of Saccharomyces cerevisiae PEP4 was added to a synthetic medium (Yeast carbon base- YCB) supplemented with YM (1%) and 0.1% tryptone.

100 ml of an overnight culture of the yeast are added. The head space is removed by adding enough YM broth to fill up the reactor, and then all the probes are inserted.

Oxygen transfer measurements were made by degassing the fermenter with nitrogen and following the rise of dissolved oxygen on a chart recorder as air was reintroduced through the tubes. Measurements were made with a New Brunswick galvanic oxygen probe.

## RESULTS & DISCUSSION

### Yeast growth

In order to evaluate the reactor under actual growth conditions, cultures of yeast were grown under a variety of reactor conditions. Figure 1 was an initial run at low gas pressure but high flow rate. There was no attempt to control pH or temperature. The data showed us that the apparatus and sterilization techniques could be employed to culture yeast cells. The effect of lowering the flow rate by one half and increasing the pressure is shown in figure 2. Again, the system worked well and the rate of cell growth increased as is shown by the quicker depletion of oxygen (20 hours vs. 30 hours).

Since oxygen was apparently supplied at adequate levels, an attempt was made to evaluate the lower working point of the apparatus. The time at which oxygen depletion occurred as a function of reactor conditions was used as the basis for evaluating the lower working limit of the apparatus. The initial experiment in this series is shown in figure 2. With only 50 feet of tubing, 7.5 psig. and 1 liter/min flow rate, the reactor reached oxygen depletion after about 14-15 hours. However, the possibility that glucose depletion was the cause for lowered oxygen consumption could not be ruled out. In the experiment shown in Figure 3, the flow rate was lowered even more and the glucose measurements were taken more frequently. The results showed that glucose depletion had not occurred simultaneously with oxygen depletion. This indicates that the cells are growing at a rate that was a direct function of oxygen supply. The other observation was that by lowering the flow rate to 0.5 liter/min, the point at which oxygen was depleted was shifted to 16-17 hours. This is slightly higher than the value shown in Figure 2 and is consistent with the fact that airflow was half that of the value used in the Figure 2 experiment. The cells are still healthy and normal. The maximum cell count is 1.3 grams per liter. This is not a high density, but it is encouraging for our first design.

These simple experiments showed the following:

1. The reactor could be sterilized, operated and maintained using the simple equipment employed (i.e. no temperature or pH control) to provide meaningful results.
2. Oxygen limitation can be reached in a relatively short time permitting quick analysis of the system.
3. Measurements of oxygen transfer rates will need to be conducted in order to estimate actual maximum operating limits.

Oxygen transfer studies

The oxygen transfer data from the step response studies were analyzed by the method of Ruchti et al. (3), and expressed as the product of the overall mass transfer coefficient and the surface area per unit volume of reactor,  $K_{1a}$ . The measurements were taken for a range of air flow rates and stirrer speeds and are given in Table 1.

The biological experiments demonstrated that modest cell dry weights could be obtained with this design of fermenter before oxygen limitation was reached. While these results are encouraging they clearly are not adequate for a practical system. To overcome the inherent limitation of the preliminary equipment design, the oxygen transfer studies were initiated. The values of  $K_{1a}$  obtained were some 50-100 times lower than in conventional stirred fermenters operating under terrestrial conditions. They correspond to oxygen transfer intensities of around 0.04 kg  $O_2/m^3/hr$ .

Three main effects can be expected to contribute to the low oxygen transfer intensities observed in this study:-

- a. film diffusion resistance in the tube containing the gas
- b. external film diffusion into the bulk liquid
- c. oxygen diffusion across the silicone tubing wall

For laminar flow of the gas and liquid, resistances a and b above will be reduced as the flow rate past the tubes is increased while resistance c will be unchanged. From fluid mechanics it is known that the mass transfer coefficient will vary inversely with the square root of the flow rate. A common way of therefore assessing the relative importance of the contributions is to plot the reciprocal of  $K_{1a}$  vs. the reciprocal of the square root of the flow rate, extrapolate to zero on the axis, i.e., infinite velocity which removes the film resistance and compare the magnitude of the residual mass transfer coefficient (4).

$$\frac{1}{K_1} = \frac{1}{(\text{velocity, internal})^{1/2}} + \frac{1}{(\text{velocity, external})^{1/2}} + (\text{membrane diffusion resistance}) \dots \dots (1)$$

Figure 4 shows this procedure for the internal flow rate variation experiment. The graph shows a marked slope implying that indeed the internal diffusion resistance in the tube is substantial and that major improvements in oxygen transfer can be expected simply by increasing the flow rate, perhaps with recycle, through the tubes.

The residual mass transfer resistances can now be subtracted out and the effect of external film resistances examined. Figure 5 shows the same kind of graph, this time produced by changing the stirrer speed. Again a substantial slope is observed with the regression line passing through the origin of the graph, i.e., at infinite stirrer speed the mass transfer coefficient becomes infinite. The interpretation of this is that the external fluid resistances are extremely high compared to which any resistance from the oxygen diffusion across the membrane is negligible.

These results are very reassuring as they imply that redesign of the equipment can be done in ways that will result in very substantial increases in oxygen transfer efficiency that will permit large increases in cell mass to be obtained long before the diffusion resistances in the tubes themselves start to become important.

The reactor will be reconfigured to reflect these findings.

### CONCLUSIONS

1. Yeast can be successfully grown in a phase separated fermenter that should be capable of operation independent of gravity.

2. The current design limitations can be overcome and will result in substantial increases in oxygen transfer intensities which in turn will support greater cell masses to provide a practical test facility for a CELSS test bed.

TABLE 1 Mass transfer coefficients ( $K_{1a}$ ) as a function of system variables.

Airflow Rate (lit/min)	Stirrer Speed (rpm)	$K_{1a}$ (hr <sup>-1</sup> )
9.5	325	4.20
7.5	325	2.75
5.0	325	2.64
2.5	325	2.08
7.5	275	3.47
7.5	275	2.75
7.5	225	2.77
7.5	110	1.97
7.5	155	1.29



## REFERENCES

- Bell, W.L., A. Miedaner, J.C. Smart, D.L. Dubois and C.E. Drostow. 1988. Synthesis and Evaluation of electroactive CO<sub>2</sub> carriers. NASA SAE Technical Paper Series. Paper 881078.
- Dunlop, E.H., and R. Williams. 1978. Physicochemical aspects of Protein bound substances. Part II- kinetics of removal. Medical & Biological Engineering 16:350-362.
- Ruchti, G., I.J. Dunn and J.R. Bourne. 1981. Comparison of Dynamic Oxygen Electrode Methods for the Measurement of K<sub>1a</sub>, Biotech. Bioeng. 23 277-290
- Seshan, P.K., G.R. Petersen, B.J. Beard and E.H. Dunlop. 1986. Design Concepts for Bioreactors in Space in CELSS " NASA Technical Manual 88215.

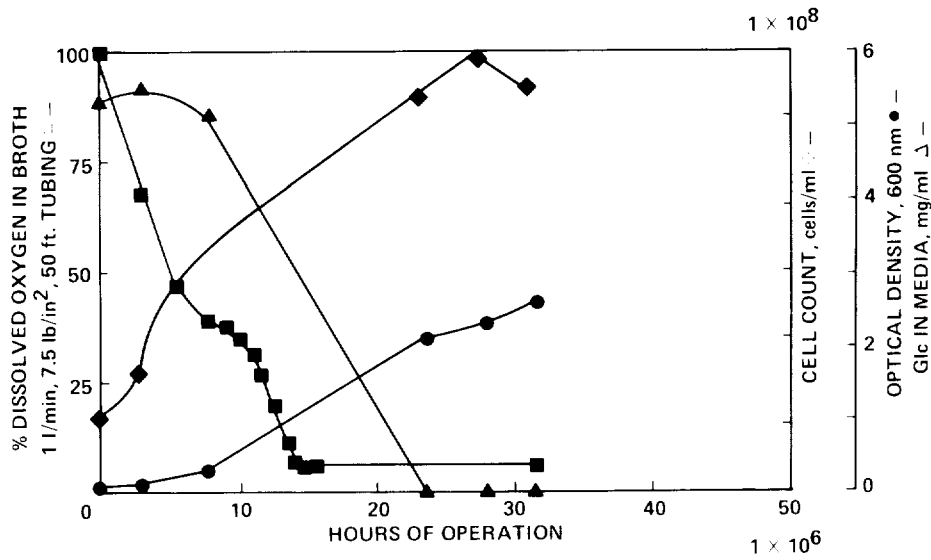

Fig. 1. Initial evaluation of the fermenter. The lowest working point of the fermenter was established. With only 50 feet of tubing, 7.5 psig. and 1 liter/min flow rate the reactor reached oxygen depletion after about 14-15 hours.

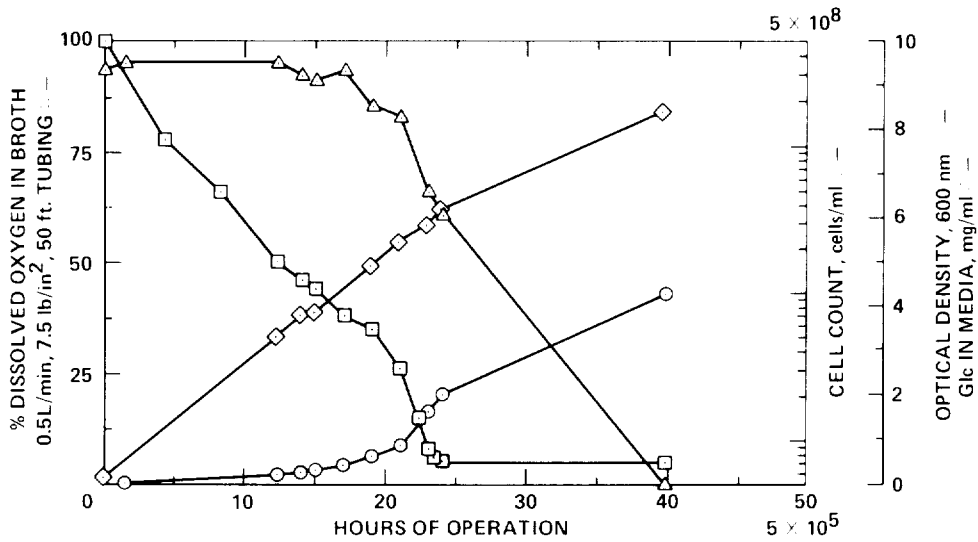

Fig. 2. At even lower flow rate glucose depletion does not occur simultaneously with oxygen depletion, indicating that the cells are growing at a rate that was a direct function of oxygen supply.

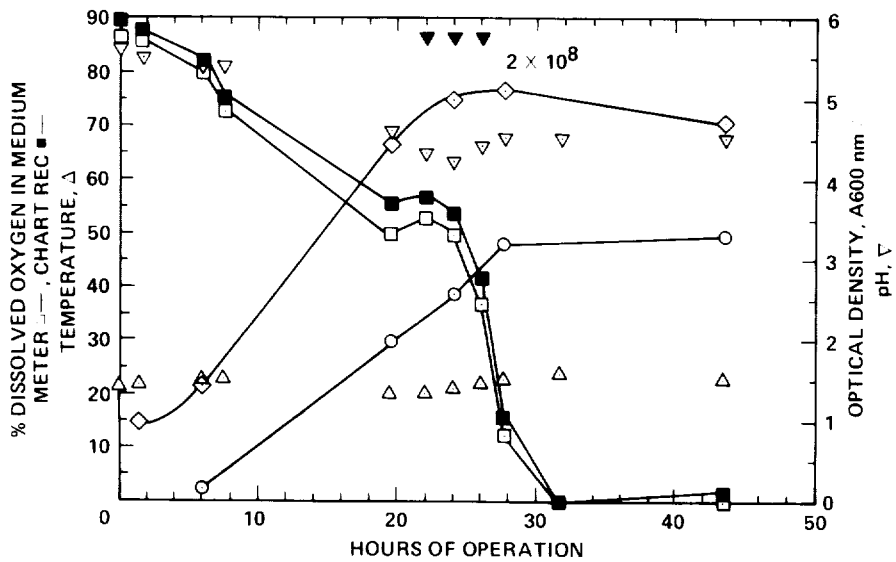

Fig. 3. Further reduction in the flow rate shows that the cells were growing at a rate that was a direct function of the oxygen supply. Thus oxygen will remain the limiting nutrient in these experiments.

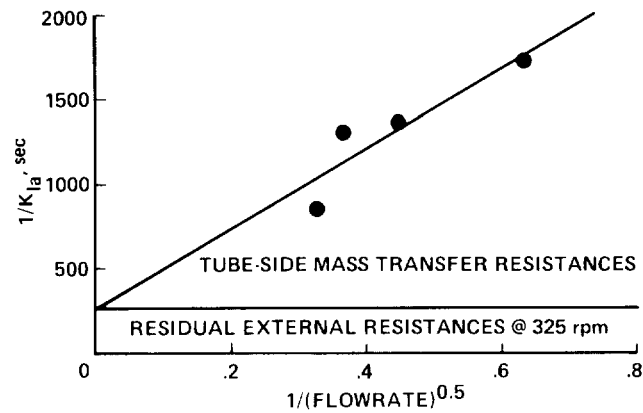

Fig. 4. The procedure for assessing the internal flow rate resistances. The graph shows a marked slope implying that indeed the internal diffusion resistance in the tube is substantial and that major improvements in oxygen transfer can be expected simply by increasing the flow rate.

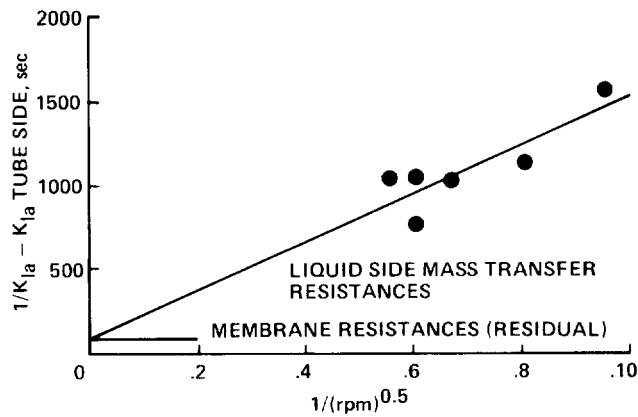

Fig. 5. The residual mass transfer resistances from Figure 4 are subtracted out and the effect of external film resistances examined by changing the stirrer speed. Again a substantial slope is observed with the regression line passing near the origin of the graph, i.e. at infinite stirrer speed the mass transfer coefficient becomes infinite, implying that the external fluid resistances are extremely high compared to which any resistance from the oxygen diffusion across the membrane is negligible.

**DESIGN CHALLENGES FOR SPACE BIOREACTORS**

P.K.Seshan and G.R.Petersen  
Jet Propulsion Laboratory  
California Institute of Technology  
Pasadena, CA 91109

**ABSTRACT**

The design of bioreactors for operation under conditions of microgravity presents unique problems and challenges. Absence of a significant body force such as gravity can have profound consequences for interfacial phenomena including cohesion, adhesion and interphase heat and mass transport. Marangoni convection can no longer be overlooked. Many speculations on the advantages and benefits of microgravity can be found in the literature. Very few have been demonstrated by incontrovertible experimental evidence.

Initial bioreactor research considerations for space applications had little regard for the suitability of the designs for conditions of microgravity. Closed loop flow schemes were touted with oxygen sparging, CO<sub>2</sub> bubble coalescence and CO<sub>2</sub> venting as if microgravity made no difference in these operations. However, during this decade, the scientific community has become keenly interested in advancing the fundamental questions pertaining to operation of bioreactors under microgravity.

Bioreactors can be classified in terms of their function and type of operation. The complex interaction of parameters leading to optimal design and operation of a bioreactor is illustrated by the JSC mammalian cell culture system. The design of a bioreactor is strongly dependent upon its intended use as a production unit for cell mass and/or biologicals or as a research reactor for the study of cell growth and function. Therefore a variety of bioreactor configurations are presented in rapid summary. Following this, a rationale is presented for not attempting to derive key design parameters such as the oxygen transfer coefficient from ground-based data.

A set of themes/objectives for flight experiments to develop the expertise for design of space bioreactors is then proposed for discussion. These experiments, carried out systematically, will provide a database from which engineering tools for space bioreactor design will be derived.

PRECEDING PAGE BLANK NOT FILMED

## 1. INTRODUCTION

Enabling technologies for closed ecological life support systems(CELSS) are under various stages of development around the world. CELSS must provide a safe and healthy human habitat in extra-terrestrial locations. A major responsibility of CELSS is to meet the need for food and biologicals and thus ensure the health and survival of mankind in outer space. Bioreactors for the production of unconventional food sources, food supplements and pharmaceuticals as well as for the treatment of wastes (primarily lignocellulosics) have become a part of such developmental efforts.

The scientific research community in the field of cell biology is being challenged with questions concerning the behavior of various cells under microgravity and other environmental conditions prevailing in extra-terrestrial locations. The understanding of such cell function and behavior to be developed through carefully planned investigations will be of great value in realizing NASA's goals for extended human presence in space during the early 21st century.

It has been recognized that terrestrial bioreactors cannot be operated as such under microgravity. New designs appropriate for extra-terrestrial applications have to be developed. Such design effort cannot proceed without new design tools and methodology in the field of variable-gravity bioprocess engineering. This approach requires a well orchestrated experimental program which can provide reliable and quantitative answers to all the questions of the engineers charged with the challenge of designing, building and operating space bioreactors.

## 2. CONSEQUENCES OF THE ABSENCE OF GRAVITY

It is not clear whether the basic biochemical kinetic rates and even the basic phenomenon of molecular diffusion are functions of the gravitational body force. However, our knowledge of interactions between dissimilar fluid phases and of convection currents induced by thermal and concentration gradients within a fluid phase, lead us to deduce a significant dependence for mass and heat transport on the magnitude and direction of a body force such as gravity.

Under conditions of microgravity, natural convection induced by buoyancy forces is insignificantly small while Marangoni convection driven by surface tension gradients can produce dramatic effects. The dominance of buoyancy forces over viscous forces has been represented by a dimensionless group called the Grashof number. This group takes on two forms depending on whether the buoyancy is caused by thermal gradients or concentration gradients as shown below:

$$\text{Thermal Grashof Number, } Gr_t = \frac{D^3 \rho^2 g \beta \Delta T}{\mu^2}$$

$$\text{Concentration Grashof Number, } Gr_c = \frac{D^3 \rho^2 g \zeta \Delta x}{\mu^2}$$

$$\text{Here } \beta = - \frac{1}{\rho} \left( \frac{\partial \rho}{\partial T} \right)_{P,x}$$

$$\zeta = - \frac{1}{\rho} \left( \frac{\partial \rho}{\partial x} \right)_{P,T}$$

P = Pressure

T = Temperature

D = A typical dimension of the flow field

$\rho$  = Density

g = Gravitational acceleration

$\Delta T$  = Temperature change along flow direction

$\mu$  = Dynamic viscosity

$\Delta x$  = Concentration (mole fraction) change along flow direction

The relevance of these Grashof numbers is readily appreciated by considering the typical dependence of mass and heat transfer coefficients on them. A typical mass transfer coefficient,  $k_x$  can be written as function of its corresponding Grashof number Gr as follows:

$$k_x = \frac{c D_{AB}}{D} f_G (Gr Sc)$$

where c = bulk molar concentration

$D_{AB}$  = Diffusivity of species A through B

Sc = Schmidt number,  $\mu/\rho D_{AB}$

$f_G$  = Correlating function

Similarly, a typical heat transfer coefficient can be written as

$$h = \frac{k}{D} f_G (\text{Gr Pr})$$

where  $k$  = Thermal conductivity

$\text{Pr}$  = Prandtl number,  $C_p \mu / k$

$C_p$  = Specific heat at constant pressure

Under microgravity, buoyancy due to thermal and concentration gradients can be negligibly small and hence the corresponding Grashof numbers close to zero. This correlates with very small mass and heat transfer rates as shown in the above equations. However, we cannot categorically assert that spontaneous phase separation is impossible under conditions of microgravity. Even though there can be little buoyancy within a fluid phase in the absence of gravity, there can be significant convection currents originating at the interfaces of two or more fluid phases in contact. Such convection currents are induced by surface tension gradients associated with temperature and concentration differences along the interfaces. The relative magnitude of surface tension driven convection to viscous and molecular effects is represented by the dimensionless Marangoni groups which take on the following forms:

$$\text{Thermal Marangoni number, } \text{Ma}_t = - \frac{d\sigma}{dT} \frac{D \Delta T}{\mu k}$$

$$\text{Concentration Marangoni number, } \text{Ma}_c = \frac{d\sigma}{dx} \frac{D \Delta x}{\mu D_{AB}}$$

where  $\sigma$  = Surface tension

Through similarity, it may be possible to correlate the dependence of the Marangoni mass and heat transfer on the corresponding Marangoni numbers as follows:

$$\text{Marangoni mass transfer coefficient, } k_{Mx} = \frac{c D_{AB}}{D} f_M (\text{Ma Sc})$$

$$\text{Marangoni heat transfer coefficient, } h_M = \frac{k}{D} f_M (\text{Ma Pr})$$

where  $f_M$  = Correlating function.



Spontaneous phase separation by Marangoni convection can be expected when surface tension values are very sensitive to changes in temperature and/or concentration. If such fluid phases are found in a bioreactor, gas bubbles or liquid droplets can be found to move towards hotter regions of the interfacial surface or towards regions of higher concentration along the interfacial surface. Marangoni convection can be augmented or retarded by body forces such as gravity depending on the direction and magnitude of the body force with respect to the convection vector. The relative dominance of surface tension forces over gravity forces can be represented by a ratio of Marangoni and Grashof numbers which reduces to the following elegant form:

$$\frac{\text{Acceleration due to surface tension gradient}}{\text{Acceleration due to gravity}} = \frac{\left(\frac{\partial\sigma}{\partial\rho}\right)\left(\frac{1}{D^2}\right)}{g}$$

When significant Marangoni effects prevail, the interfaces cease to be quiescent and the resulting interfacial turbulence augments mass and heat transfer rates across interfaces (Skelland 1974). However, such effects cannot be predicted to any acceptable degree of accuracy because of the complex and interactive dependence of surface tension gradients on changes in species concentrations and temperature. For example, interfacial turbulence is promoted by the following factors:

1. Microgravity
2. Solute transfer out of a high viscosity phase
3. Solute transfer out of a low diffusivity phase
4. Large differences in kinematic viscosities or molecular diffusivities between contacting phases
5. Large concentration gradients near the interface
6. Large changes in surface tension for small changes in concentration or temperature
7. Low viscosity and diffusivity in both phases
8. Absence of surfactants
9. Large interfacial area

From the above discussion it is clear that microgravity can significantly enhance surface effects and interfacial phenomena (Day and Ray, 1985). As a

the absence of forced convection. Microgravity can alter such surface effects as cohesion and adhesion. Even if one of these effects can be anticipated in a space bioreactor, its performance can be expected to depart significantly and nonlinearly from terrestrial performance.

### 3. SPECULATIONS ON THE ADVANTAGES AND BENEFITS OF MICROGRAVITY

Tairbekov (1983) concluded without convincing evidence that "free-living unicellular organisms are indifferent to variations in the magnitude and direction of the gravitational field.

Jordon (1974), Mayeux (1977) and Kober(1970) variously attributed the following enhancements in bioreactor performance to microgravity, again without adequate evidence and well-controlled and scientifically sound experiments:

- (a) Increase in cell growth rate
- (b) Increase in cell population densities
- (c) Increase in biological production (enzyme, vaccine, etc.) from microbial fermentation
- (d) Higher levels of oxygen solubility in nutrient solution
- (e) Greater control of convection/mixing to suit shear-sensitive mammalian cells

A report by Arthur D. Little Inc. (1978) speculated on a purely imaginary model of gas exchange through a membrane under microgravity where the gas was presumed to form a layer on the liquid side of the membrane as well and prevent the liquid from wetting the membrane.

The Biosatellite II Project was commissioned to evaluate the effect of weightlessness on bacterial growth. It was found that the density of Salmonella typhimurium cells grown under microgravity was higher than that for terrestrial culture of the same bacterium. This led to a number of "off-the-cuff" speculations. Mattoni (1963) attributed the increased cell density to enhanced efficiency of nutrient transfer to and waste product removal from the cells. Nyiri (1976) attributed the same to better oxygen transfer under microgravity.

None of the above speculations was followed up by any serious scientific effort to verify and validate them. This volume of the proceedings of the Cells II conference contains a number of interesting papers on the effect of microgravity, viz., the production of growth hormone in rat pituitary cells, inhibition of blastogenic response, and response of carrot cells. However, fundamental questions such as the dependence of biokinetic rate, marangoni driven convection, basic molecular diffusivity, viscosity, thermal conductivity, thickness of laminar sublayer, the turbulent boundary layer etc. on microgravity remain unanswered today.

#### 4. COMPLEX PARAMETRIC INTERDEPENDENCE IN A SPACE BIOREACTOR

A serious attempt at designing and operating a bioreactor under microgravity is in progress at NASA-JSC (Cherry, 1985).

The bioreactor employs mammalian cells cultured on microcarrier beads. Oxygenation of the nutrient liquid and cell growth are carried out in two separate chambers. Unlike earlier concepts (Charles, 1979 and Gitelson, 1975) where oxygen sparging and carbon dioxide venting were not examined for feasibility of operation under microgravity, the JSC design is well thought out for its intended application. The cell growth chamber is a continuously stirred tank reactor where the agitation rate is optimized to reduce damage to the shear-sensitive cells while providing adequate homogeneity of oxygen and nutrient concentration throughout the reactor volume.

This reactor is designed for low rates of oxygen delivery and a great concern for minimizing cell damage due to bead-bead and bead-impeller collisions. The primary design objective of minimizing cell damage can be accomplished in one or more of the following three ways:

- (a) Increase in turbulent eddy size
- (b) Decrease of bead-bead collision frequency
- (c) Decrease of bead-impeller collision frequency

Turbulent eddy size could be increased by

- (a) increasing the kinematic viscosity of the nutrient solution,
- (b) decreasing the impeller diameter, and/or
- (c) decreasing the impeller speed.

On the contrary, any of these measures would reduce the homogeneity of the reactant mixture and thus tend to decrease production.

Bead-bead collision frequency could be decreased by

- (a) decreasing the volume fraction of beads and/or
- (b) increasing bead diameter.

Again, to the contrary, decreasing the volume fraction of beads would entail production cutback and increasing bead diameter would result in more violent collisions leading to increased cell damage.

Bead-impeller collision frequency could be decreased by

- (a) decreasing bead size,
- (b) decreasing impeller speed,

(c) decreasing impeller diameter, and/or

(d) decreasing the number of impeller blades.

Decreasing the bead size could increase the bead-bead collision frequency but the collisions will be less energetic. However, reduction in impeller characteristics (speed, diameter and number of blades) could compromise homogeneity and hence production.

In addition to the recognition of all the above design trade-off issues, it was also determined that coating the impeller blades with an elastic material could soften the bead-impeller collision and reduce cell damage therefrom. It was estimated that laminar boundary layer could cause very little damage to the mammalian cells.

The above example was presented here to illustrate the complexity of the decision process in designing the bioreactor for just one criterion, viz., minimal cell damage.

## 5. SPACE BIOREACTOR CONFIGURATIONS

A space bioreactor could be designed in a variety of configurations to meet a corresponding variety of operational needs and constraints.

If production is the objective, the configuration chosen should accommodate the conditions of cell culture at the required production rate for the least reactor volume. Shear-hardy yeast cells grown as an alternate food source in space habitats will require a fermenter which can take advantage of high agitation rates and rapid oxygen supply rates for maximum cell growth rate. On the other hand, biological production (enzymes, vaccines, etc.) using highly shear-sensitive mammalian cells will require gentler operation and appropriate hardware configuration such as the JSC bioreactor. Again, the hardware and operation will vary depending on the need for photosynthetic, aerobic and other requirements of any candidate cell culture.

For the case of scientific investigations to examine the possible effects of microgravity on microbial cells, the design of bioreactors depends on the specific questions to be answered. Three broad categories of effects of microgravity on cells can be formulated as a starting basis for providing generic bioreactor hardware for scientific investigations:

1. Cell biology effects such as DNA replication, cell division and morphology

2. Intracellular metabolic effects

3. Microbial ecological effects such as the intercellular metabolic dependencies found in heterogeneous microbial populations

By carefully surveying all potential investigations in the above three categories, a set of design requirements for generic bioreactor hardware can be derived. A set of generic bioreactor hardware can then be designed, built,

and ground-tested by the potential investigators before committing the hardware for microgravity environments.

From a purely hardware point of view, a space bioreactor can operate in a phase-separated configuration or phase-mixing configuration. Operationally, each of these can be classified under "batch", "semi-batch", "fed-batch" and "continuous". The following diagram shows a logical arrangement of various phase-separated bioreactors:

PHASE-SEPARATED BIOREACTORS

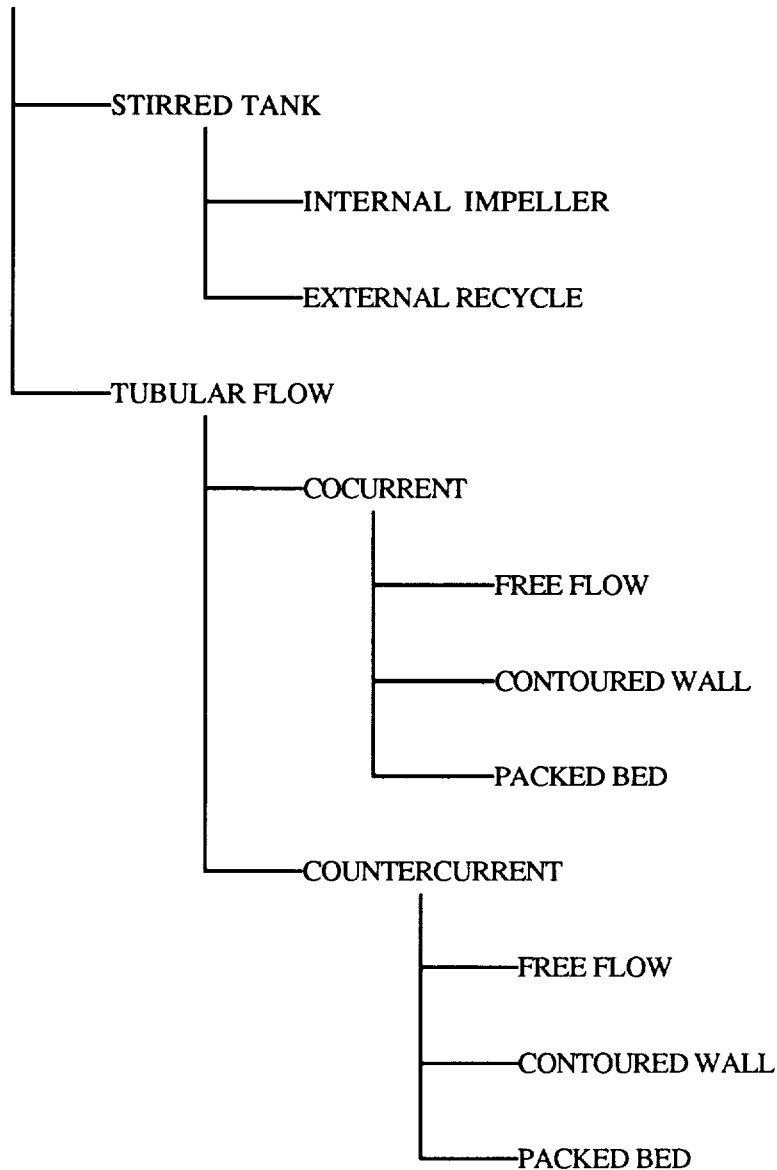

Phase-separated designs utilize oxygen delivery to the culture medium through gas-permeable membranes. Stirred tank bioreactors are suited for moderate product concentrations. Temperature control is easily accomplished in these reactors. Figure 1 is a schematic of a phase-separated stirred tank bioreactor with internal impeller. This design permits fast cell growth rates

under conditions of vigorous agitation. For shear sensitive cells, soft impeller and slow stirring speeds are recommended. Oxygen is supplied by permeation through a bundle of tubes. Oxygen can be the carrier gas for carbon-dioxide venting or a separate interspersed tube bundle can be provided for carbon-dioxide removal. If photosynthesis is warranted, an interspersed bundle of light pipes (e.g., optical fibers) must be accommodated inside the tank. To maintain anaerobic conditions, the oxygen can be replaced by an inert carrier gas or a suitable absorbing medium for carbon dioxide.

A phase separated stirred tank with an external recycle pump replacing the impeller of the previous design is illustrated by Figure 2. This design is suitable for slow reactions and moderate product concentrations. The vigorous agitation obtained in the previous design can be accomplished through very high pumping (recycle) rates. Channeling between pump input and output must be prevented by appropriate baffle arrangement. This design under mild agitation rates is suitable for slow reactions and moderate product concentrations. This design is not suited for shear-sensitive mammalian cells mounted on carrier-beads. However, a mild peristaltic pump may be appropriate for non-anchored shear-sensitive cell culture.

Tubular flow designs are not normally meant for batch, semi-batch and fed-batch modes of operation. However, these modes may be very appropriate for cell science research. For instance, in the various batch modes, introducing a small amount of culture inoculant at one end of a tube containing a rich nutrient medium will provide a continuous study of cell growth from early to late stages of cell development and lifetime. For production of cell mass at very high concentrations, a continuous tubular bioreactor will be appropriate. Figure 3 shows three design concepts for phase-separated tubular bioreactors with cocurrent flow of nutrients and oxygen/carrier gas. Cocurrent designs are not the most efficient for maximizing production rate of cell mass. However, this type of operation can maintain aerobic and anaerobic conditions at either end of the same reactor to meet the special needs of a scientific investigator. In the above designs, nutrient solution is shown in the annular flow and the oxygen/carrier medium in the central tubular flow. These two can be interchanged without serious consequences. Free flow concepts permit little radial uniformity of concentrations except under highly turbulent flow conditions. The presence of a contoured wall can improve radial uniformity with minimal shear penalty. The packed bed designs can provide the equivalent of intense agitation radially over an axial length equal several packing diameters. These designs can also accommodate photosynthetic organisms through suitable light piping. If high rates of oxygen and nutrient supply are required, oxygenation of the nutrient medium can be accomplished in a separate vessel and the oxygenated nutrient solution can be made to ooze rapidly into a largely porous tube instead of a gas-permeable membrane.

Tubular countercurrent designs shown in Figure 4 are especially suited for continuous cell culture with very high product cell densities. These designs supply the most oxygen where most needed, i.e., the product end of the tube. By maintaining laminar flow of the nutrient medium, mild hydrodynamic conditions can be provided for shear sensitive cultures. Again, as for the cocurrent designs, oxygenated rich nutrient solution can be made to ooze through porous tubing to sustain rapid high density cell cultures.

Countercurrent flow schemes provide the most economical reactor size for a given production rate. Free flow tubular bioreactors are for gentle slow culture. Contoured wall tubular bioreactors improve mixing efficiency without excessive turbulence. If contouring is implemented with soft elastomeric materials, this type of reactor can be compared with JSC stirred tank bioreactor for mammalian cells and trade-off studies can then provide a technology choice for mammalian cell culture in space. Even though packed tubular reactors can provide a high degree of radial mixing and hence favor rapid cell growth, the advantages gained must be offset against the bioreactor volume occupied by the packing. A trade-off study and a break-even plot will lead to the right combination of packing type, size, volume and flow rates to maximize cell mass production rate.

Phase-mixed reactors will not operate under microgravity since an efficient phase separation following mixing cannot be implemented in these reactors without introducing artificial body forces such as in centrifugation. So we can conceive of two types of phase mixed bioreactors as shown in Figure 5. In the rotating stirred tank bioreactor, gases are sparged through the liquid. Phase mixing is accomplished by countercurrent flow of gas and liquid and uniformity of concentration in the liquid phase is accomplished by a very high rate of recycle of the culture. The need for high recycle rates can be offset by providing packing material inside the bioreactor volume as shown for the rotating packed bed in Figure 5. The rotating packed bed designs can benefit from commercial Hige technology development by the Imperial Chemical Industries of England. By implementing carbon dioxide removal from the gas discharge, oxygen can also be recycled for economy of operation. Where high oxygen input rates are desired, an oxygenator must be inserted in the liquid recycle loop. These designs can also accommodate batch, semi-batch and fed-batch modes of operation of the bioreactor. In the phase-mixed designs, cocurrent arrangements are not feasible. Even though tubular flow rotating reactors can be conceived and built, the designs can provide no weight/volume advantages over those illustrated above.

In the case of a slow culture, to obtain significant product output a large reactor volume will be required. If dense cell mass output is desired, a long tubular flow bioreactor design will be favored. The long tube can be accommodated by a spiral-wound or hairpin-bend type arrangements.

For high rates of oxygen delivery, the phase-separated stirred tank bioreactor can be configured as a combination of two stirred tanks, one large and one small as shown in Figure 6. In this scheme, the nutrient recycle rate can be as high as 100 times the product delivery rate. The filter shown above prevents cells from entering the oxygenation tank along with the nutrient recycle while building up high cell densities inside the bioreactor.

## 6. KEY DESIGN PARAMETERS

Measuring the values of molecular diffusivities, viscosities, thermal conductivities and interfacial tension under conditions of microgravity has a great scientific merit since comparison of these numbers to the corresponding terrestrial numbers will greatly enhance our fundamental understanding of the role of gravity.

However, when it comes to designing a space bioreactor, these basic numbers are not immediately useful. For engineering design we need typically one or more of the following for any particular reactor configuration:

- (1) Individual Mass transfer coefficients,  $k_l$  or  $k_{la}$  and  $k_g$  or  $k_{ga}$  or overall mass transfer coefficient  $K_l$  or  $K_{la}$  or  $K_g$  or  $K_{ga}$  as a function of reactor throughput rate.
- (2) Individual or overall heat transfer coefficient as a function of reactor throughput rate.
- (3) Agitator or recycle pump power demand as a function of reactor throughput rate.
- (4) Residence time distribution(RTD) as a function of reactor throughput rate. No bioreactor will operate as an ideal plug flow or a perfectly stirred tank reactor. Experimentally obtained RTD's can be used to correct idealized mathematical models for actual non-ideal effects. The non-ideal effects are caused by dead spots, partial segregation and partial micromixing within real bioreactors.

There are additional parameters of interest to the design engineer such as genetic mutation and radiation shielding which we shall not discuss here.

Using the above information, the design engineer will compute the reactor volume, gas transfer area, heat transfer area, impeller/recycle pump specifications etc. Through carefully planned flight experiments the above parameters must be obtained as a function of reactor size using sound scale-up procedures. There is no alternative to this approach.

To illustrate why mass transfer coefficients etc. must be measured under conditions of microgravity and cannot be derived from basic diffusivity etc. data let us consider the liquid film coefficient for oxygen transfer,  $k_{la}$ . This coefficient, though defined through an Ohm's law type relationship, is not a constant even with respect to the concentration differential.  $k_{la}$  is a complex composite parameter which includes the effects of all the following and more.

- (1) Gas bubble size, membrane tube diameter and microbial cell dimensions
- (2) Fluid density, viscosity and diffusivity
- (3) Temperature, pressure and concentration distributions which depend on forced and Marangoni convection effects not easily modeled for a microgravity environment.
- (4) Agitation intensity (recycle rate, impeller diameter, impeller blade size, shape and number, impeller speed)
- (5) Fermenter and gas exchange geometry and arrangement of gas permeation tube bundle.



- (6) Turbulent eddy dynamics with free cells or carrier-attached cells or both
- (7) Counter diffusion of carbon dioxide and moisture into gas bubbles or gas stream
- (8) Effect of microgravity on some or all of the above

The dependence of  $k_{ja}$  or other mass transfer coefficients on all of the above is complex and non-linear.  $k_{ja}$  does not scale in the same way as reactor size and agitation rate do (Oldshue, 1966).

Similar considerations apply for heat transfer coefficients if significant interfacial heat effects are involved.

In this context, it is interesting to observe how confusing and unreliable some of the research efforts have been in the area of estimating  $k_{ja}$  values for bioreactors. To illustrate this, let us consider the claim in the literature (Charles, 1979) of an ingenious procedure to calculate oxygen transfer  $k_{ja}$  from kinetic rates of oxidation of glucose to gluconic acid and hydrogen peroxide. Here, the glucose solution was sparged with air in a separate vessel. The air-sparged glucose solution was pumped to a reaction vessel and filled up without any head space and closed up. The enzyme glucose oxidase was then injected into the reaction vessel to the reaction started. The dissolved oxygen in the reaction vessel was traced against time and the rate of glucose oxidation was computed. It is then claimed that a big and unwieldy expression converts this glucose oxidation rate into the mass transfer coefficient in the air sparging vessel. No dissolved oxygen trace was reported to have been made for the air sparging operation. More details of how this feat was accomplished would indeed be interesting.

## 7. SUGGESTED THEMES FOR FLIGHT EXPERIMENTS

In addition to normal operation of candidate space bioreactors in microgravity and having obtained all the pertinent values of state and operating parameters, the following boundary values must be obtained in order to have a clear picture of operational bounds for the bioreactors in parametric space.

- (a) Effect of microgravity on biokinetic rate.

By maintaining near-complete nutrient and oxygen availability for a low cell population, the cell growth rate shall be measured. The same must be studied under anaerobic conditions to understand product selectivities and changes, if any, in biochemical pathways under microgravity.

- (b) Effect of microgravity on oxygen transfer rate.

By maintaining high cell population and oxygen availability just above the onset of anaerobic pathways within the cell, the cell growth rate or oxygen consumption rate shall be determined under microgravity. The same must be studied with minimal nutrient availability.

(c) Effect of microgravity on heat transfer.

By feeding preheated oxygen gas and cooling the reactor walls to maintain a uniform product outlet temperature, obtain the heat transfer rate and any associated change in oxygen mass transfer rates under both the kinetic and transport limited operations. By judiciously varying temperature profiles inside the bioreactor, onset of vigorous Marangoni turbulence must be studied.

(d) Effect of microgravity on residence time.

(e) Effect of microgravity on scale-up laws.

At least three different sizes of the same bioreactor configuration must be tested under identical microgravity environment to obtain all relevant data to derive scale-up laws to guide efficient future designs of space bioreactors.

Using standard pulse and step input methods, residence time distributions for candidate bioreactors must be obtained under microgravity.

In order to determine whether a direct correlation exists between terrestrial performance and microgravity performance of identical bioreactors, identical experiments shall also be conducted on earth and the data cross-plotted to derive such a correlation.

To improve our basic understanding of the effect of microgravity on fundamental physico-chemical and fluid dynamic parameters, standard testing procedures for measurement of diffusivity, solubility, viscosity, boundary layer properties, etc. must be carried out in microgravity and the results obtained must be correlated with terrestrial results to elicit the role of gravity on these basic parameters.

## 8. CONCLUSIONS

Until proven otherwise, current opinion in the scientific community that microgravity can significantly affect the performance of space bioreactors guides our strategy for design of flight experiments.

Operation of bioreactors involve complex parametric interdependences which are not readily modeled without experimental data under actual conditions of operation such as microgravity.

A variety of bioreactor configurations and operational modes are available for extra-terrestrial applications. It is possible to obtain a consensus among the CELLS research community and thus select one or more of the configurations for provision of generic bioreactor hardware facilities on board the space station and other extra-terrestrial locations.

Some of the bioreactor designs presented here are particularly suited for maximum cell mass/ biologicals production and should facilitate the effort towards alternate/unconventional food generation in controlled ecological life support systems.

In addition to flight experiments for developing basic understanding of cell growth and function under microgravity, the design of space bioreactors

will be handicapped without the benefit of flight experiments designed to derive key engineering design parameters applicable to microgravity operation. Of particular concern is the determination of scaling laws pertaining to any micro/variable gravity environments. Without such a thorough engineering design infrastructure, design of bioreactors for space applications will lead to considerable waste of effort through trial/error type redesign and considerable delays in accomplishing major manned missions under serious consideration by NASA.

#### 9. ACKNOWLEDGEMENT

The concept study presented in this paper was carried out by the Jet Propulsion Laboratory, California Institute of Technology, under a contract with the National Aeronautics and Space Administration.

## REFERENCES

- A.D. Little, Inc., Cell Culture Biosynthesis, Final Summary Report, December 1978.
- Nyiri, C.M. and L.K. Nyiri. 1979. Development of a Space Bioprocessing System.
- Cherry, R.S. and E.T. Papoutsakis. 1985. Shear and Mixing Effects on Cells in Agitated Microcarrier Tissue Culture Reactors. Space Bioreactor Science Workshop Proceedings, NASA-JSC, August 22-23.
- Day, D.E, and C.S. Ray. 1985. Chapter 6A, Opportunities for Academic Research in a Low Gravity Environment. G.A. Hazelrigg and J.M. Reynolds (eds). Prog. in Astro. & Aero., Vol.108.
- Jordon, R.T. 1974. Earth Orbital Systems and Biomedical Research. AAS Paper 72-157, pp 109-140.
- Kober, C.L. 1970. Chemical and Biochemical Space Manufacturing. Unique Manufacturing Processes in Space. NASA-MSFC, ME-70-1, April.
- Mattoni, R.H.T. 1963. Spaceflight Effect and Gamma Radiation Interaction on Growth and Indications of Lysogenic Bacteria. Bioscience. Vol.18, pp 602-608.
- Mayeux, J.V. 1977. Influence of Zero-g on Single Cell Systems and Zero-g Fermenter Design Concepts. NASA-LBJSC, Bioprocessing
- Nyiri, L.K. 1976. Some Questions of Space Engineering. Colloquium on Bioprocessing in Space, NASA-JSC. March 10-12, pp 159-180.
- Oldshue, S.Y. 1966. Biotech. Bioeng., Vol. 8 No.3.
- Skelland, A.H.P. 1974. Diffusional Mass Transfer. Wiley-Interscience. pp 290-91.
- Tairbekov, M.G. et al. 1983. Experimental and Theoretical Analysis of the Influence of Gravity at the Cellular Level: A Review. Adv. Space Res. Vol 9, pp 153-158.

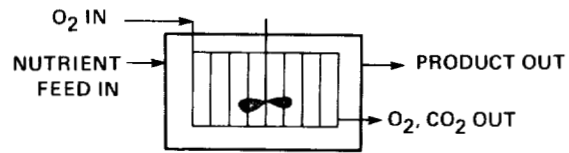

Figure 1. Phase-separated stirred tank with internal impeller.

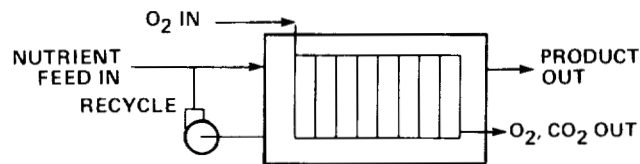

Figure 2. Phase-separated stirred tank with external recycle pump.

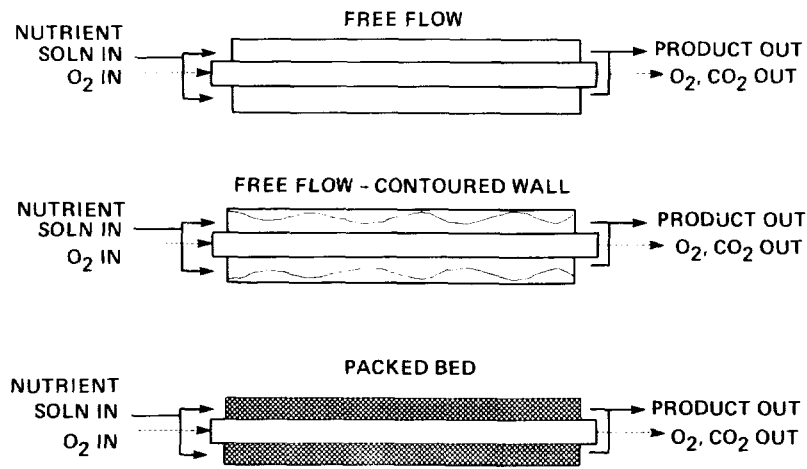

Figure 3. Phase-separated tubular cocurrent bioreactors.

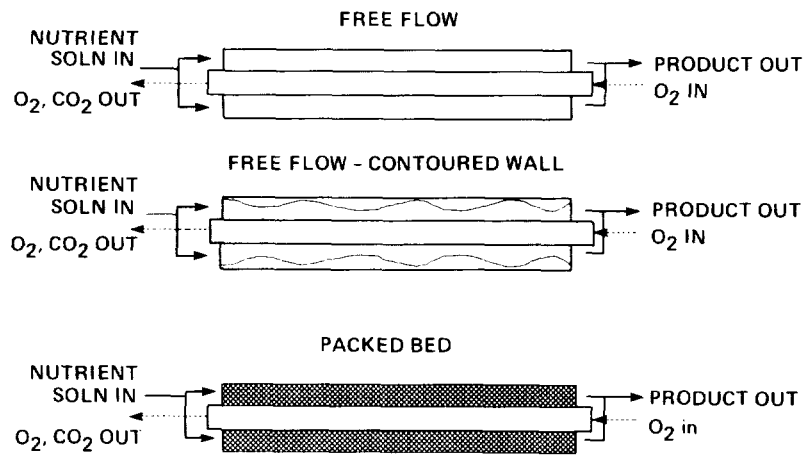

Figure 4. Phase-separated countercurrent tubular flow bioreactors.

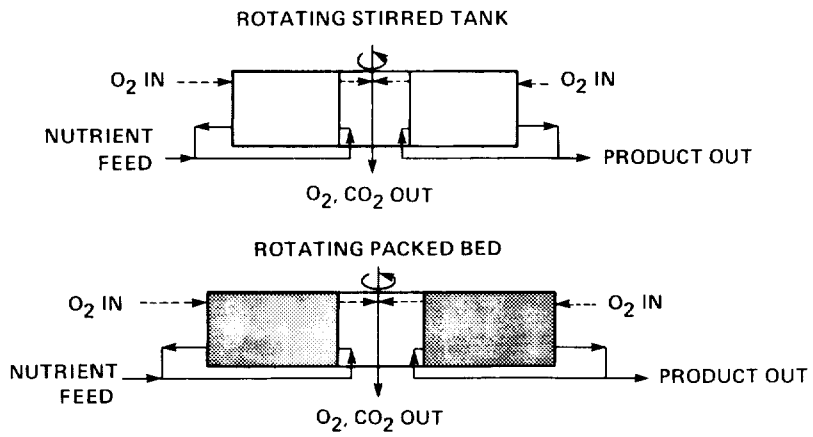

Figure 5. Phase-mixed rotating bioreactors.

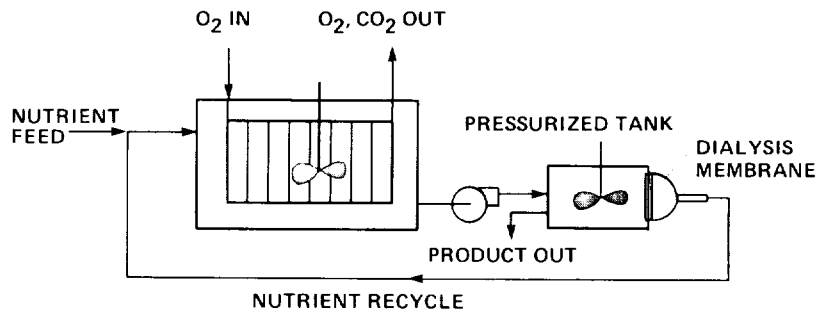

Figure 6. Phase-separated stirred tank bioreactor for high oxygen delivery rates.

## FERMENTATION AND OXYGEN TRANSFER IN MICROGRAVITY

Eric H. Dunlop  
 Colorado State University  
 Department of Chemical Engineering  
 Fort Collins, CO 80523

## ABSTRACT

The need for high rate oxygen transfer in microgravity for a CELSS environment offers a number of unique difficulties and challenges. The use of a phase separated bioreactor appears to provide a way of overcoming these problems resulting in a system capable of providing high cell densities with rapid fermentation rates. Some of the key design elements are discussed.

## PURPOSE

Biological processing and thus fermentation is likely to take place in space under two main driving forces. Firstly, as unique biological effects are uncovered in microgravity, and as novel bioseparation processes particular to the microgravity environment are developed, it is likely that some fermentation, for example on the space station, will become appropriate. It is likely however that such fermentations will be of slow growing cells such as mammalian cells that do not require high rates of oxygen transfer. While the studies discussed in this paper may be of relevance in this field it is not the primary focus. Secondly, as deep space exploration becomes more developed it becomes necessary to recycle the carbon used in food systems, the so-called Controlled Ecological Life Support Systems (CELSS), and in waste processing subsystems. Here high rates of oxygen transfer are necessary to permit systems of reasonable weight, volumetric and power effectiveness.

## PROBLEMS

## a. Bubble rise velocities

In a conventional fermenter bubbles of air are introduced into the bottom of a vessel. The bubbles rise through the liquid transferring their oxygen to the liquid. In microgravity the bubbles simply will not rise. A conventional fermenter will therefore not work.

## b. Oxygen transfer intensity

Figure 1 is an attempt to show the interaction between the exponential cell growth of yeast (the likely target organism) in the absence of oxygen limitation for a range of doubling times from 1 to 4 hours. This is indicated by the solid lines. At low cell densities, yeast can double in well under an hour. The broken lines show the cell mass that can be supported, at 50% carbon conversion, for differing oxygen transfer intensities of between 1 and 5 Kg O<sub>2</sub>/m<sup>3</sup>/hr. It shows that for cell dry masses of likely importance in a CELSS

PRECEDING PAGE BLANK NOT FILMED



environment that oxygen limitation will dominate under most conditions and should thus be the focus of our studies.

c. Blowing bubbles

The simplest heuristic example is blowing a bubble of air, density  $\rho_G$ , in a stationary fluid of density  $\rho_L$ . The bubble is being blown from a tube of diameter  $d_0$  into water of surface tension  $\gamma$  to produce a bubble which will eventually breakaway from the tube when a critical diameter  $d_b$  is reached. At that point it is possible to write a force balance on the bubble - the surface tension force will exactly balance the gravitational forces induced by density differences (and thus buoyancy).

$$\frac{\pi d_b^3}{6} (\rho_L - \rho_G) g = \gamma \pi d_0$$

Rearranging gives the simple formula :-

$$d_b = \left( \frac{6 \gamma d_0}{g(\rho_L - \rho_G)} \right)^{1/3}$$

The implication of this equation is interesting when one examines the effect on  $d_b$  as  $g$  is reduced. Being on the bottom line of the equation it is seen that as  $g \rightarrow 0$   $d_b \rightarrow \infty$ . The physical interpretation of this is that the bubble diameter becomes infinitely large as the gravity becomes infinitely small or, more realistically, that a phase inversion will occur whereby one obtains a dispersed phase of liquid droplets in a continuous phase of gas. The usual situation is a continuous phase of liquid and a dispersed phase of gas.

d. Rigid spheres vs. internal circulation by convection

Assuming that the above problem can be overcome in some ingenious way, we are still left with another problem relating to bubble size. The rate of oxygen transfer from a bubble is given by:-

$$-d [O_2]/dt = K_1 a (C_i - C_0)$$

where  $C_0$ ,  $C_i$  are the bulk and interfacial concentrations of oxygen respectively, and  $a$  is the surface area of bubbles per unit volume of reactor.  $K_1$  has been extensively measured for a number of gases in water, particularly for large bubbles. In large bubbles internal circulation of the gas takes place, driven by density induced convection. This greatly enhances the rate at which mass transfer of oxygen takes place. Very small bubbles however readily attract impurities which adsorb on the surface of the bubble making in behave like a solid sphere and, more importantly for our purposes, the closeness of the bubble walls to each other inhibits the process of internal circulation and so reduces mass transfer many times. This produces the

paradoxical effect that mass transfer from large bubbles is frequently greater than from small bubbles, i.e.,  $K_L$  goes through a maximum with respect to bubble diameter with mass transfer actually decreasing as the bubble diameter increases. Figure 2 below, based on the original graph of Motarjemi and Jameson(1978), shows this effect clearly. The effect is analogous to the situation encountered with multiple glazing of windows. If the separation between the panes of glass is too great then density gradients induce internal circulation which actually enhance heat transfer and so destroy the purpose of installing the insulation. For bubbles in microgravity no circulation will take place as the convective forces due to density and hence gravity will not be operable.

Small bubbles

Large bubbles

Large surface area.

Smaller surface area

Reduced internal circulation

Enhanced internal circulation.

In microgravity all bubbles will have no internal circulation and hence will have a poor mass transfer rate for the transport of oxygen.

SOLUTIONS

As in most technical situations one can deal with a problem by removing the conditions that cause the problem, learn to live with it, create a different environment in which the problem can be solved or avoid the need to solve the problem. Where the last solution is available it is usually to be preferred.

Solutions range from creating gravity artificially by rotating the equipment at a sufficient speed to induce the necessary gravity to rotating devices that contact the gases and liquids at high shear and ignore the microgravity. The solution proposed here is to avoid the need to solve the problem by separating out the gas phase that causes the problems. This can be done simply by filling the fermenter with tubing, silicone or fluorocarbon, which have a high permeability to oxygen. Calculations (Seshan et al, 1986) indicate that 10% of the fermenter volume occupied by silicone tubing should be more than adequate for the high oxygen rates envisioned in this fermentation. About 1% of the tubing would be capable of removing the carbon dioxide so produced. On the inside of the tube passes either air or oxygen gas separated from the liquid phase by the membrane. Another possibility is the use of oxygen carriers and carbon dioxide absorbers. A number of liquids have a high solubility for oxygen, among them obviously are the liquid silicones and fluorocarbons from which the membranes are made. Other possibilities include the synthetic hemoglobin analogs that are currently being developed. Carbon dioxide removers are available that range from the poorly reversible traditional absorbers such as monoethanolamine to the newly developed redox-switched substituted quinones and metallocenes (Bell et al, 1988) in which  $CO_2$  is absorbed at one redox potential but rapidly given up by small changes in the potential. Calculations show that 1 kg  $O_2/m^3/hr$  should be realistically obtainable. One of the hidden advantages of such a system is that while it is designed to operate in space it should operate equally effectively on the ground where most of the experimentation and

validation can be performed. Such systems have already been tested on a bench scale (Petersen G.R., P.K. Seshan, E.H. Dunlop. 1989. Phase separated membrane bioreactor: results from model system studies. Advances in Space Research, 1989. In Press.).

#### CONCLUSIONS

1. A conventional fermenter will not operate in microgravity.
2. A phase separated fermenter appropriately designed will support high cell densities at a high rate of growth.
3. Testing of the phase separated fermenter on the ground should provide most of the necessary design information without the need for expensive flight tests.

#### REFERENCES

- Bell, W.L., A. Miedander, D.L. Smart, D.L. Dubois and C.E. Drostrom. 1988. Synthesis and evaluation of electroactive CO<sub>2</sub> carriers. NASA SAE Technical Paper Series. Paper 881078.
- Motarjemi, M. and G.J. Jamieson. 1978. Effect of bubble size on oxygen utilization in aeration processes. Chapter 3. 'New Processes in Waste Water Treatment and recovery.' Ed. G. Mattlock, Ellis Horwood.
- Seshan, P.K., G.R. Petersen, B.J. Beard and E.H. Dunlop. 1986. Design concepts for bioreactors in space in CELSS. NASA Technical Manual 88215.

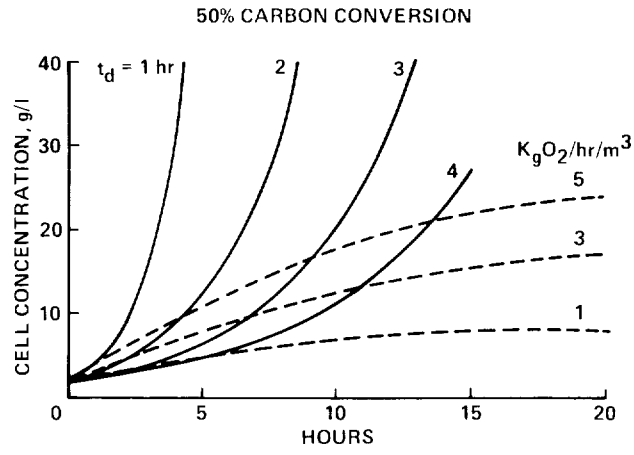

Figure 1.

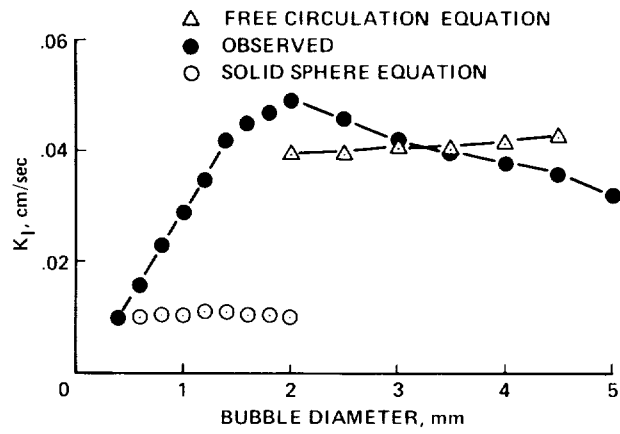

Figure 2.

## COUNTERMEASURES TO MICROGRAVITY

Marvin W. Luttgés  
 Aerospace Engineering Sciences and  
 Bioserve Space Technologies  
 University of Colorado  
 Boulder, CO 80309

Many physiological systems sustain easily documented changes as a consequence of exposure to the space environment. Most often recorded in studies of astronauts, these changes are believed to be largely the effects of microgravity. Areas of physiological interest are summarized in Table 1. The problems may have rapid onset as common to the neurovestibular effects that cause space adaptation syndrome. Entry and exit to the microgravity environment are often highlighted by vertigo and gastric disturbances. Or, the problems may be protracted as in the case of bone deterioration that develops somewhat more slowly and that recovers slowly upon return to normal gravity. Unfortunately, the direct causes of these and the other alterations are poorly understood. Thus, direct countermeasures may be especially difficult to implement. Accordingly, I have attempted to provide a conceptual set of considerations for obviating the effects of microgravity. The exercise may be whimsical but the thought it is meant to provoke may change the way we approach some microgravity problems.

Based upon observations of biological systems exposed to the space environment, it seems helpful to provide a structure within which to categorize classes of effects. Simply, some effects may be quite passive consequences of microgravity related to fluid redistributions or losses of mechanical loading. Others may signal an active cellular or tissue response to the altered environment in which they are immersed. Finally, some effects are reactive in that cells and tissues respond actively but inappropriately to the environment created by microgravity. Examples of such effects are provided later. However, it is crucial to recognize that such effects may have intracellular, membrane, immediate extracellular, tissue, organ or organism sites of action.

The passive consequences of microgravity translate into a variety of hydrostatic, mechanical and electrical effects. For example, fluid compartments change, loads on cells and tissues change and even a variety of piezoelectric changes may occur. Other alterations occur, as well. At the organism level, the consequences of fluid columns existing in the absence of loading and pressure changes promote passive, active and reactive effects, for example, in the cardiovascular and lymphatic systems. At the tissue level, these effects are reflected in cardiac, vascular and, perhaps, immune system changes. Mechanical and piezoelectric effects may be linked in regard to bone changes. But, it is critical to recognize that some of the known effects of microgravity on bone could result from passive microgravity influences on bone circulation or from the extracellular dynamics of bone formation and deterioration. Reactive changes are most evident in fluid shifts to the upper body that result in hormone messages that signal increased kidney function. Or, unweighted gravity sensors of the inner ear may produce spurious signals that produce disorientation in the central nervous system as well as altered neuromuscular-cerebellar communication to the peripheral nervous system. In the former, the system simply behaves in a normal way, ignorant of the

microgravity. In the latter case, the system may be adapting to a point of accepting "noise" as a signal. In any event, candidates for microgravity influences are both numerous and complicated. As stated above, poor understanding of causal mechanism leads to limited and, perhaps, ineffective countermeasures; or worse, contra-indicated countermeasures.

The list in Table 1 summarizes physiological "problem areas" in regard to a few microgravity effects. Within each area effects are not well understood at any physiological level, and it is difficult to determine whether the effects arise from passive, active or reactive consequences of microgravity exposure. A sample of candidate causal factors is listed in Table 2. Taken together, the problems and their causes constitute an almost complete biomedical sciences research agenda, with or without the complications of the space environment exposure that may involved even more than microgravity and radiation exposures. However, Table 2 highlights several microgravity influences that have escaped serious research commitments. Direct mechanical effects on cells, tissues, organs and organisms have not received systematic attention except at high levels of exposure meant to simulate various traumatic insult circumstances. Direct tissue elasticity influences of mechanical loading have only recently received enhanced levels of research attention and, then, the attention is limited to cardiovascular studies. Yet, it is readily apparent that biological systems do function in the presence of nominal gravity and that such functioning may include a variety of dependencies on the presence of gravity-induced influences on the physiological environment. The problem may be that the gravity influences are so ubiquitous that they have escaped serious consideration. The space environment may make us rethink our present complacency regarding the importance of gravity in living organisms. The survival and function of biological systems in space may be a simple reflection of robustness and inadvertently produced protection protocols.

It is against this backdrop that we have begun to study ways to alleviate microgravity effects on biological systems. And, it is from the above outlined "view" of the microgravity effects that we make some guarded recommendations. In several instances we have proposed remedies that appear facetious. This has been done to encourage a rather open-minded view of both the nature of the problems and possible countermeasures. It may be necessary to originate new methods or treatments. Modifications of existing treatments for use in space may be inadequate. And overall, we may need to institute some broad, novel concepts of space physiology.

#### Candidate Solutions

The items in Table 3 suggest several strategies for handling the microgravity problems. Such strategies, of course, are not particularly novel. The strategies range from replacement of nominal levels of gravity to broad pharmacological treatments. Again, we are reminded that we are speculating on therapies without much knowledge of the nature of the problems. In some sense, replacements are the most innocuous treatments to attempt. We start there.

Perhaps the most common solution to microgravity problems is the simple replacement of what's missing -- gravity. A variety of rotating space habitats have been suggested including the now classic rotating torus concept circa 1950's. Realistically, we have very little data that focuses directly on the

consequences of using centripetal forces as a substitute for gravity. Studies done with a variety of centrifugal methodologies have interpretation difficulties due to mixed centripetal-gravitational vectors, centripetal gradients and Coriolis effects. Thus, the simple replacement of a gravity vector may be much more difficult than expected. At this time, it would be difficult to envision relevant physiological studies unless they were actually conducted in the space environment.

Associated with the above biological interpretation difficulties are the implementation difficulties of creating a man-rated rotating space habitat. Structural problems would, at this time, be difficult to anticipate and center of mass asymmetries could contribute to much precession and wobble. These problems are additive to the problems of spin-up or spin-down and the problems of egress or safety.

It seems to follow from the above comments that evaluations in the 1.8 meter centrifuge planned for Space Station Freedom will provide the biological rationale either for undertaking or dismissing the possibilities for a rotating habitat. Even this capability will leave questions unanswered. So, a strong rationale for a rotating habitat may be quite far away.

The present approach to reduction of microgravity effects, of course, centers on exercise. The value of this approach and the limitations are already reasonably well documented in what might be considered preliminary demonstrations. The difficulty here is that exercises done in space have neither been done consistently nor done in a highly controlled fashion. Subject numbers have been small and subjects have varied considerably in a number of important ways; age, health, conditioning level, sex etc. It is yet to be determined whether or not we have identified and used the most effective exercise protocols. Nevertheless, the critical drawback of exercise is that (1) it does not seem to be a panacea for treatment of all microgravity effects and (2) it takes a significant toll on the length of time astronauts might otherwise have available for productive experiments, observations and maintenance. If exercise is to be the mainstay treatment for microgravity effects it must be made more effective and less time consuming. Ideally, it should be made recreational, as well. Such constraints, together, lead to a difficult challenge for medical practitioners and exercise physiologists.

For a number of tissues, it appears that some degree of healing and/or protection from deterioration might be afforded using either electrical or magnetic fields. At Bioserve we have pursued these possibilities for a rodent tail suspension model using changes in bone as the focal point of our analyses. Pulsed magnetic fields have prevented the bone deterioration usually seen in tail-suspended mice. Many variables, of course, are important. Field strength, pulse characteristics, field orientation, animal age and duration of daily treatment have been considered experimentally. Some of these results were reported at the annual ASGSB, 1988 meetings. Currently, effects of magnetic field treatments are being done for nervous system and muscular system tissues as well as bone. All of the experiments are promising but we are trying to (1) learn the limits of these treatments, (2) look for any evidence of side effects and (3) sculpture the protocols for tests in the microgravity environment.

Our observations with these electromagnetic effects raised the possibility that rather ubiquitous force gradients (in the above case, magnetic fields) might substitute for some of the gravity forces experienced by organisms. The resulting "mixed gradients" could have desirable consequences at the organism, tissue and even cellular levels. We have begun to formalize this kind of hypothesis. It may not be unreasonable to assume that other ubiquitous variables could be found, as well. Again, however, the challenges and problems are significant in understanding and using such approaches to counteracting microgravity effects.

The next approach to devising countermeasures is the use of passively-induced gravity effects. This approach makes several assumptions about the causal factors, in microgravity deterioration or dysfunctions. Simply stated, the assumptions relate to some unquantified and uncharacterized need of organisms for gravity-promoted bulk fluid motions and mechanical force gradients. The effects might relate to modest mixing within cellular milieus, differential forces produced across a cell and/or cell membrane, organ distortions with allied mechanical and fluid forces generated asymmetrically within the organ, or to organism asymmetries, again, leading to a variety of different forcing functions. The linking of such forces is evident, for example, in the galloping horse that uses the various locomotive forces to aid in respiration. Evidence for the importance of such effects is just now arising from experimental literature. Nevertheless, some speculation on associated countermeasures to microgravity-induced losses of such factors seems warranted.

Assuming that fluidic mixing at a variety of tissue compartment levels is to be accomplished and that mechanical forces are to be generated across such tissue compartments, the replacement strategies appear quite clear. Direct acceleration and deceleration forces can be applied to the organism in microgravity. Or, direct mechanical forces can be applied. This treatment, I suppose, is tantamount to suggesting that astronauts be made to "bounce off the walls" in an almost literal sense. The resulting brief episodes and differing vectors for acceleration -- deceleration forces may provide fluid mixing and mechanical shear forces otherwise lost to the microgravity environment. Following some hypothetical biological need for gravity, it appears that a fair amount of direct mechanical stimulation should be provided. This could range from slow, broad coverage stimulation nearing whole body massage to rapid, narrowly directed stimulation such as focused ultrasound. With appropriate selection of acoustical wavelengths and intensities, it might be possible to effect virtually all tissue, organ and cellular compartments regardless of size and distance from the body surface. The beneficial effects might be reduced flow stagnation, reduced need for metabolic pumping across the cells and tissues in lieu of mechanical gradients, and enhanced tissue reactivity to stimuli like stretch stimuli used to maintain skeletal muscle tonus or stretch stimuli needed to elicit rather autonomous smooth muscle responses. Whether such approaches are likely to aid in the search for countermeasures remains to be seen. However, it seems equally important to evaluate the need of biological systems for such fluidic and mechanical stimuli. It may be important to separate the gratuitous production of these effects by exercise such that exercise can be supplanted, in duration, by more passive mechanical and fluidic stimulation. This approach allows more time for the simultaneous production of useful work in space by the astronauts.



For a number of biological effects produced in microgravity, it is tempting to employ directed pharmacological treatments. Thus, the microgravity dysfunctions are treated like any of a large number of other medical maladies. Many and more powerful drugs are being developed. Some, like calcium loss inhibitors for bone, are at the threshold of FDA approval. Yet, at some point or another, it seems reasonable to question the use of drugs since already a major segment of American society is taking drugs to reduce the side effects of other drugs or is at risk in taking drugs with one another that don't mix either chemically or pharmacologically. The thing to be remembered here is that all drugs are "poisons." Unless a ubiquitous drug is found that is capable of treating most microgravity effects in different tissues at about the same time, drugs made for the variety of known physiological dysfunctions of microgravity would undoubtedly yield an unacceptably large number of side effects. Where possible to elicit general systemic effects, the drug would have to promote stasis or general anabolic biases --- this, of course, is a situation being pursued by world class athletes and the side-effects of these treatments are only too well known. As above, the implementation of pharmaceutical countermeasures to microgravity makes more assumptions about our information and therapeutics wizardry than we could reasonably live up to for several decades.

The other treatments mentioned as countermeasures simply reflect some current beliefs about nutrition and organism health. Even in the nominal gravity conditions of Earth it is difficult to reconcile the role of nutrition in health and disease states. The impact may be subtle and the required studies for corroboration must be, by nature, longitudinal. Only now are we beginning to grasp the significance of and the methodologies for longitudinal studies that may extend for 3 or 4 decades.

From each of the somewhat wistful comments regarding protection from microgravity effects in space, two things are abundantly clear. (1) We really don't know what the microgravity effects on biological organisms are! And, (2) we are not especially accomplished in instituting effective countermeasures for any of a wide variety of known medical dysfunctions. Yet, we are likely to have to control microgravity effects or minimize the influences of such effects on astronauts if Space Station Freedom is to become an effective reality. We must use this rather overwhelming challenge to learn what we can regarding biological system dependence on gravity, biological dysfunctions without gravity and biological independence from gravity. Only then, can long space missions become a reality and can man's future as a spacefarer be assured.

# COUNTERMEASURES TO MICROGRAVITY

## PROBLEM AREAS

MUSCULOSKELETAL  
CARDIOVASCULAR  
MICROBIOLOGICAL  
RADIATION  
FLUID/ELECTROLYTES  
IMMUNOLOGICAL  
PULMONARY  
PHARMACOLOGICAL  
BEHAVIORAL  
TOXICOLOGICAL  
NEUROVESTIBULAR

Table 1

# COUNTERMEASURES TO MICROGRAVITY

## CAUSAL FACTORS

WEIGHTLESSNESS  
NO CONVECTION

Loss of shear stresses on cells  
and tissues

Loss of some fluid motion

Fluid redistributions

Altered tissue elasticity-fluid  
interactions

Reduced cell to cell  
communication

### ALTERED INTERNAL MILIEU

Erroneous sensor function

Erroneous mechanical vectors

Altered hormonal states

Table 2

# COUNTERMEASURES TO MICROGRAVITY

## CANDIDATE SOLUTIONS

ARTIFICIAL GRAVITY  
EXERCISE-INDUCED  
MECHANICAL EFFECTS  
ELECTROMAGNETIC  
EFFECTS  
PASSIVELY-INDUCED  
GRAVITY EFFECTS  
DISABLED SENSORS  
NUTRITION  
ARTIFICIAL CHANGES IN  
CHEMICAL MILIEU

Table 3

BONE MINERAL MEASUREMENT USING DUAL  
ENERGY X-RAY DENSITOMETRY

Steven W. Smith  
Lunar Radiation Corporation  
Madison WI 53713

## ABSTRACT

Bone mineral measurements before and after space missions have shown that weightlessness greatly accelerates bone demineralization. Bone mineral losses as high as 1 to 3% per month have been reported. Highly precise instrumentation is required to monitor this loss and thereby test the efficacy of treatment. During the last year, a significant improvement has been made in Dual-Photon Absorptiometry by replacing the radioactive source with an x-ray tube. Advantages of this system include: better precision, lower patient dose, better spacial resolution, and shorter scan times. The high precision and low radiation dose of this technique will allow detection of bone mineral changes of less than 1% with measurements conducted directly at the sites of interest. This will allow the required bone mineral studies to be completed in a shorter time and with greater confidence.

## INTRODUCTION

It is well known that weight bearing bones demineralize if not subjected to mechanical stress. While the mechanism of this bone loss is not understood, it is clear that the reduced bone mineral density impairs the mechanical integrity of the skeletal system and may result in bone fractures. X-ray evidence of this demineralization is present at about 12 weeks in patients immobilized by major fractures or paralysis. Manned space flights have shown that extended periods of weightlessness have a similar effect. In US space flights lasting as long as 3 months, loss of bone mineral has not impaired the functional capabilities of astronauts. However, the prospect of extended and repeated flights requires additional bone mineral research to protect the health and insure the performance of space crews.

During the last year, a significant improvement has been made in Dual Photon Absorptiometry bone mineral measurement by replacing the radioactive source with an x-ray tube. Many factors motivate this change. The greater output flux of the x-ray tube permits shorter scan times and better precision. The smaller focal spot permits better beam collimation which results in better spatial resolution and lower patient dose. In addition, elimination of the radioactive material simplifies licensing and eliminates the need for yearly source replacement. These developments have been commercialized to monitor bone disorders in the general public. This paper discusses the operating principles of this new instrumentation and how it can be applied to manned space flight.

## BONE DEMINERALIZATION

A gradual loss of bone mineral is normal throughout adulthood. It has been well established that bone mineral density decreases about 1% per year with variation depending on the site examined (Krolner and Pors Nielsen, 1982; Riggs et al, 1982). Many mechanisms are responsible for accelerated

bone loss beyond this natural ageing process. Bone demineralization is a significant health problem for post menopausal women. In the United States, osteoporosis affects some 15 to 20 million persons, and results in more than 1 million fractures annually. The lifetime risk of a hip fracture to a female in the United States is about 15%, a similar risk as for breast cancer. Almost 20% of these fracture patients die within six months, and it has been estimated that 40% of the survivors do not return to the independence of their pre-fracture life-style.

While osteoporosis is a significant problem to the general public, it is an even greater problem to manned space flight. Bone mineral measurements before and after extended space missions have shown that weightlessness greatly accelerates bone demineralization. Bone mineral losses as high as 1 to 3% per month have been measured (Anderson and Cohn, 1985). At this rate of reduction, bone fractures could be expected in as little as 1-2 years. After returning to a gravitational environment, this bone mineral loss is reversed and at least some of the damage is repaired. Whether or not the bone mineral is restored to a pre-space flight level is not clear. Measurements on the Skylab astronauts five years after their flights were lower than before the flights and lower than in controls (Tilton et al, 1980).

## DUAL PHOTON ABSORPTIOMETRY

Drug, diet, and exercise therapies have been suggested to reduce bone loss. A critical part of any therapy program will be the ability to make highly precise bone mineral measurements. Precision, or the ability to make repeatable measurements, is necessary to detect the small changes in bone mineral that occur over a short period of time. In past experiments, the imprecise measurements techniques have yielded error bars nearly as large as the results trying to be measured. The recently developed technique of X-Ray Dual-Photon Absorptiometry (DPA) has been demonstrated to provide better than 1% precision on measurements of the spine and the hip. These are the preferred measurement sites because they are the most common sites to be fractured as a result of low bone mineral content.

Single Photon Absorptiometry (SPA), the predecessor of DPA, measures bone mineral content by passing a monochromatic beam of gamma rays through the patient. The measured gamma ray attenuation can then be related to the amount of bone mineral that the beam passes through. The significant problem with SPA is that there is no effective way of separating attenuation due to bone from attenuation due to soft tissue. This leads to errors in accuracy and precision.

Dual Photon Absorptiometry was developed to better separate tissue from bone. The instrumentation is similar to SPA, except a radionuclide is used that emits photons at two distinct energy levels. The most commonly used radioisotope is Gadolinium-153, which emits a group of gamma rays at about 44 Kev and another group at about 100 Kev. Bone attenuates the lower energy photons much more than the higher energy ones. Soft tissue, on the other hand, attenuates both energy levels about an equal amount. This differential attenuation allows the separation of bone from soft tissue. Two equations can be written using the measured attenuation at the two energies. From these two equations, the two unknowns can be found, namely the amount of soft tissue and the amount of bone mineral.

Several methods have been suggested as to how to use an x-ray tube to perform DPA. One approach is to shape the x-ray spectrum by use of a rare

earth filter. The beam exiting an x-ray tube contains x-rays of widely varying energies. Fig. 1. shows the spectrum of two x-ray beams after passing through filters containing rare earth elements. The high absorption of the rare earth K-edges have removed x-rays with energies near the center of the spectrum. This results in two clearly defined energy peaks. These two energy peaks can then be used in the same manner as the radionuclide scanners which use the two energy peaks of Gadolinium-153. The broken line in Fig. 1. was obtained for a Samarium filter at 90 KV x-ray tube operation, while the unbroken line is for Cerium at 80 KV. These two sets of operating parameters have both been used in DPA systems.

## SYSTEM PERFORMANCE

In 1988, Lunar Radiation completed development of the Dual Photon X-ray (DPX) system. The DPX system is capable of whole body bone mineral scans as well as localized scans such as the spine and hip. Spine scans take approximately 4 minutes and require 1 mR patient dose. Spatial resolution is approximately 2 mm.

Several thousand scans on spine phantoms have shown a DPX precision of about 0.5%. Monte Carlo simulations have shown that this precision is limited by quantum statistics of the detected x-rays, implying that better precision can not be obtained without increasing the radiation dose. Several *in vivo* spine studies have been completed on the DPX. As shown in Fig. 2, a normal 25 year old male volunteer was scanned daily over a period of 3 weeks. The measured precision of this study is 0.8%, which is typical of other *in vivo* studies conducted. It should be noted that no drift is observable in the data over the three week measurement period. It should also be noted that the radiation dose received by the volunteer for the entire study was no more than for a standard chest x-ray. This combination of high precision and low dose allows repetitive measurements to detect bone mineral changes as low as 1 percent.

## CONCLUSION

The fundamental processes of bone demineralization during weightlessness are poorly understood. Additional studies are required to insure the health and effectiveness of space flight crews. X-ray instrumentation developed during the last year has significantly improved the ability to measure bone mineral, and the resulting integrity of the skeletal system. The high precision and low radiation dose of this technique allows detection of bone mineral changes of less than 1% with examinations conducted directly at the anatomic sites of interest. This will allow the required bone mineral studies to be completed in a shorter time and with greater confidence.

## REFERENCES

- Anderson, S. and S. Cohn. Bone demineralization during space flight, *The Physiologist*, vol 28, No 4, 212-217, 1985
- Krolner, B. and S. Pors Nielsen. Bone mineral content of the Lumbar spine in normal and osteoporotic women, *Clinical Science*, 62, 329-336, 1982.

Riggs, B et al. Differential changes in the bone mineral density of the appendicular and the axial skeleton with ageing. Relationship to spinal osteoporosis, *Journal of Clinical Investigations*, 67, 328-335, 1981.

Tilton, F., J. Degioanni, V. Schneider. Long term follow up of Skylab bone demineralization, *Aviat. Space Environ. Med.*, 51, 1209-1213, 1980

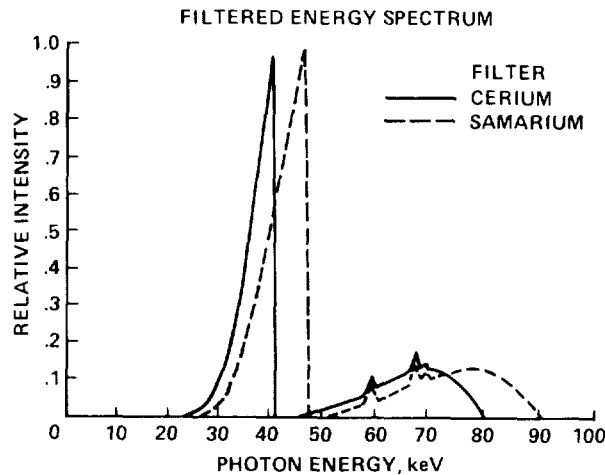

Fig. 1. Energy spectrum produced by rare earth filtration.

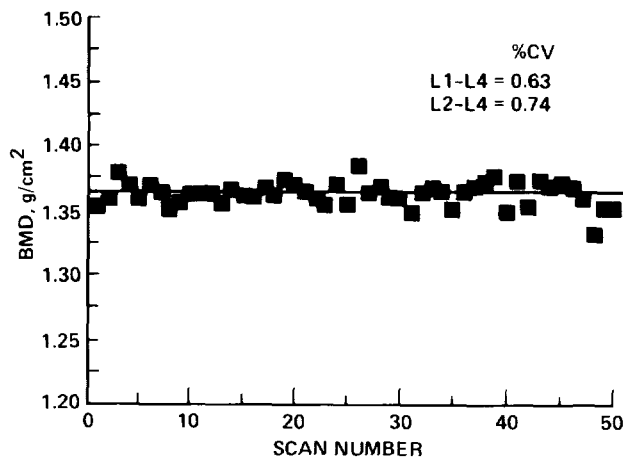

Fig. 2. Measured in-vivo precision of the DPX system.



**PRESENTATION VIEWGRAPHS**



AMES RESEARCH CENTER  
SPACE LIFE SCIENCES PAYLOADS OFFICE



NAME/ORG: P. X. CALLAHAN	TITLE: CELLS II CONFERENCE	DATE 10/31/88
-----------------------------	-------------------------------	------------------

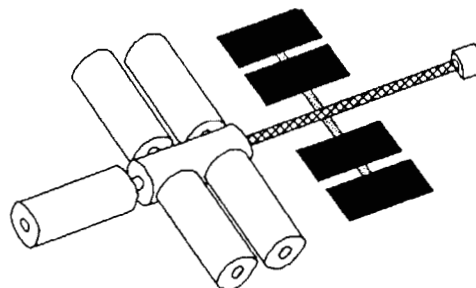
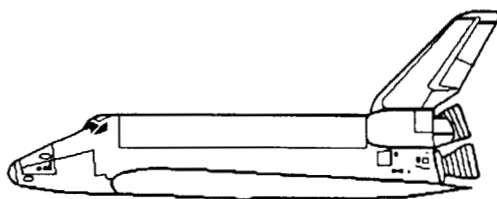

## INSTRUMENTATION: THE ADDITIONAL FACTOR THAT AFFECTS MICROGRAVITY BIOSCIENCE EXPERIMENTS

### ABSTRACT

Proper instrumentation is key to the success of a spaceflight experiment. Development of proper instrumentation for a microgravity environment, especially under the constraints imposed by a manned vehicle, is a more difficult task than might be imagined. This presentation discusses the definition, design, development and testing of instrumentation, considers the requirements, interfaces and scope of instrumentation, and provides anecdotes gleaned by the Space Life Sciences Payloads Office from simulations and flights.



AMES RESEARCH CENTER  
SPACE LIFE SCIENCES PAYLOADS OFFICE



<b>NAME/ORG:</b> P. X. CALLAHAN	<b>TITLE:</b> CELLS II CONFERENCE	<b>DATE</b> 10/31/88
------------------------------------	--------------------------------------	-------------------------

INSTRUMENTATION: THE ADDITIONAL FACTOR THAT AFFECTS MICROGRAVITY BIOSCIENCE EXPERIMENTS

SUB-TITLE: MURPHY WAS AN OPTIMIST!

**INSTRUMENTATION:**

Instrumentation is defined here broadly as all equipment required to support the experiment. When designing instrumentation, we (and hopefully the PI) consider **requirements, interfaces and scope of instrumentation**. While these are highly interactive considerations (PAYLOAD DEVELOPMENT VIEWGRAPH, VERIFICATION VIEWGRAPH), for the purposes of this presentation, they are discussed as discrete entities.

**REQUIREMENTS:**

While ground-based studies generally consider advertised (or needed) capability, availability and cost, we have additional requirements, and strongly consider (in addition to the usual **science requirements**) **reliability, training and imposed requirements**. Interaction of these in the space environment is much more extensive and apparent than in ground-based studies.

**SCIENCE REQUIREMENTS:**

Science requirements must consider not only the type of experiment to be performed, but the conditions (environment) under which it is performed, the number of subjects, and who is performing it (crew, unattended, unmanned). These aspects are generally well considered during the payload development process, but when they are not, major perturbations usually result. *Anecdotes:*

- Squirrel Monkey Feeder - Switch inadvertently disabled during S/L shutdown. No indicator.
- Urine Monitoring System - Airflow levels insufficient to control streams/boluses of water.
- Tissue Shipment - Properly packaged shipment went astray long enough for ice to "melt".
- Cell Culture System - Piston containment exerted too much pressure on cells.



AMES RESEARCH CENTER  
SPACE LIFE SCIENCES PAYLOADS OFFICE



<b>NAME/ORG:</b> P. X. CALLAHAN	<b>TITLE:</b> CELLS II CONFERENCE	<b>DATE</b> 10/31/88
------------------------------------	--------------------------------------	-------------------------

INSTRUMENTATION: THE ADDITIONAL FACTOR THAT AFFECTS MICROGRAVITY BIOSCIENCE EXPERIMENTS

INSTRUMENTATION (Cont.):  
REQUIREMENTS (Cont.):

**RELIABILITY REQUIREMENTS:**

No, you can't fix it at your bench! Reliability requirements consider not only whether the unit will perform the designated function, but also whether the unit will endanger other operations and the number of flights the unit is designed for. The review process for instruments/payloads is designed to help assure that nothing is missed. When something is, then - *Anecdotes*:

- Sea Urchin Handle - Hardware flimsy, poorly marked and incompletely tested. Limited training of crew for "carry-on". Result - Handle turned too far and equipment damaged; no results.
- Drop Dynamics Module - Failed on start-up. Crew spent most of mission on repair.
- Tissue Shipment - Properly packaged shipment went astray long enough for ice to "melt".

**IMPOSED REQUIREMENTS:**

Imposed requirements are generally of a nature to protect the crew, vehicle and other experiments. Violations of this nature (cleanliness, sharp edges, safety, ease of function, forbidden materials, etc.) prevent you from flying when discovered before launch. When discovered later, they are often major embarrassments. *Anecdotes*:

- Particulates on SL-3 - Animals produced more particulates, and air stream failed to control.
- Urine Monitoring System - See Science Requirements section.
- Monkey Door - Perforated door replaced with solid. Designer used same part number. Result - Door replaced by back-up, perforated door, and solemn assurance to Mission Manager violated.



AMES RESEARCH CENTER  
SPACE LIFE SCIENCES PAYLOADS OFFICE



<b>NAME/ORG:</b> P. X. CALLAHAN	<b>TITLE:</b> CELLS II CONFERENCE	<b>DATE</b> 10/31/88
------------------------------------	--------------------------------------	-------------------------

INSTRUMENTATION: THE ADDITIONAL FACTOR THAT AFFECTS MICROGRAVITY BIOSCIENCE EXPERIMENTS

INSTRUMENTATION (Cont.):  
REQUIREMENTS (Cont.):

**TRAINING REQUIREMENTS:**

Generally, you can't perform your own experiment. A surrogate (crew) has to do it. This means that the crewman must be as well-trained, or better trained than you. The best developed hardware is no better than the person operating it. Generally, sufficient training sessions are provided (MISSION APPROACH VIEWGRAPH). *Anecdotes:*

- Very Wide Field Camera - Scientific Airlock handle damaged; no results.
- Sea Urchin Handle - See Reliability Requirements section.
- Autogenic Feedback Training - Crew not sufficiently convinced of value; limited data.

**INTERFACES:**

Interfaces are defined here more broadly than those usually seen. For the purposes of this presentation, interfaces will be identified as **defined**, **constrained** and **controlled**. To use the current vernacular, if you don't interface, you are not part of the group (that flies).

**DEFINED INTERFACES:**

Defined interfaces are those you will find in the vehicle handbook (Spacelab Payload Accommodations Handbook). They include data, rack, power buss, telemetry, etc. interfaces. They are usually quite definitive and explicit, rarely contradictory, and often correct. *Anecdotes:*

- Rack Interfaces - Hand made, so therefore requires hand-fitting or slotted holes.
- Document Conflicts - What to do when you find them. and *when you don't*.



AMES RESEARCH CENTER  
SPACE LIFE SCIENCES PAYLOADS OFFICE

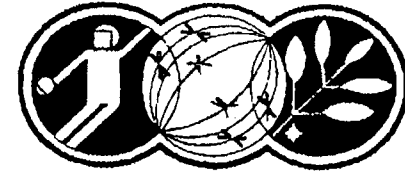

<b>NAME/ORG:</b> P. X. CALLAHAN	<b>TITLE:</b> CELLS II CONFERENCE	<b>DATE</b> 10/31/88
------------------------------------	--------------------------------------	-------------------------

INSTRUMENTATION: THE ADDITIONAL FACTOR THAT AFFECTS MICROGRAVITY BIOSCIENCE EXPERIMENTS

INSTRUMENTATION (Cont.):  
INTERFACES (Cont.):

**CONSTRAINED INTERFACES:**

Constrained interfaces are most often referred to as resources (power, weight, size, volume, crew time, data handling capability, etc.). If you do not consider them as constrained interfaces, you could be in trouble when developing hardware. In addition, they are often jello-like in spite of signed interface agreements. *Anecdotes:*

- Autogenic Feedback Training - Bulky waistpack limited usefulness; crew time requirements limited participation.
- ATMOS Vacuum Leak - SL-3 expts asked to give up/juggle operating time for ASTRO data.
- SLS-1/2 - Experiments de-manifested due to a combination of growth and oversubscription.

**CONTROLLED INTERFACES:**

Controlled interfaces come with the vehicle and include cabin pressure/temperature/humidity, gas composition, orientation, g-forces, access to vehicle, etc. They are usually very reliable until you rely on them. Then all sorts of interesting things happen. *Anecdotes:*

- Research Animal Holding Facility, Late Access - Mid-aisle transporter plus entry gantry became mid-aisle transporter plus Module Vertical Access Kit became mid-deck transporter with crew maneuver through tunnel became rack-mounted Module with MVAK servicing, and then they wanted to change from oxygen to nitrogen in Spacelab for better fire control.
- Ant Colony - Student Space Involvement Program. Ants perished on pad.
- Web Building - SSIP; Low humidity in S/L required crew to hand-feed spiders.
- RAHF - Low humidity in S/L could have contributed to particulate problem.



AMES RESEARCH CENTER  
SPACE LIFE SCIENCES PAYLOADS OFFICE

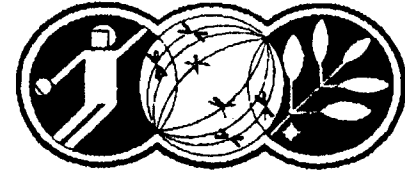

<b>NAME/ORG:</b> P. X. CALLAHAN	<b>TITLE:</b> CELLS II CONFERENCE	<b>DATE</b> 10/31/88
------------------------------------	--------------------------------------	-------------------------

INSTRUMENTATION: THE ADDITIONAL FACTOR THAT AFFECTS MICROGRAVITY BIOSCIENCE EXPERIMENTS

INSTRUMENTATION (Cont.):

**SCOPE OF INSTRUMENTATION:**

Scope of instrumentation can be delineated as **not enough, too much, wrong kind and just right.** As with Science Requirements, the scope of instrumentation is often dictated by the type of experiment, the environment, sample size, and who is performing it (crew, unattended, unmanned). Included in this section would also be telescience operations.

**NOT ENOUGH INSTRUMENTATION:**

Most reporting from Spacelab is of the negative/confirmation variety. For the sake of the experiment, you want the experiment to provide the crew with sufficient information to determine if it is proceeding properly. For the sake of your psyche, you want sufficient information to make intelligent judgements on the progress of the experiment. However, a balance must be achieved between critical information, resources and extremely competent crew. *Anecdotes:*

- RAHF Monkey Feeder - See Science Requirements section. No indicator on ground, either.
- Problem Solving - No information, no solutions.

**TOO MUCH INSTRUMENTATION:**

Over-instrumented equipment increases probability of failure and over-utilizes valuable resources. Over-instrumented specimens can also be deadly with respect to the information obtained and with respect to the specimen. *Anecdotes:*

- RHESUS Project - Concern about loops and negative feed-back.
- Biosatellite III - Over-instrumentation of Bonnie could have been a factor.



AMES RESEARCH CENTER  
SPACE LIFE SCIENCES PAYLOADS OFFICE

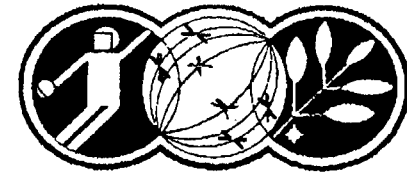

NAME/ORG: P. X. CALLAHAN	TITLE: CELLS II CONFERENCE	DATE 10/31/88
-----------------------------	-------------------------------	------------------

INSTRUMENTATION: THE ADDITIONAL FACTOR THAT AFFECTS MICROGRAVITY BIOSCIENCE EXPERIMENTS

INSTRUMENTATION (Cont.):

SCOPE OF INSTRUMENTATION (Cont.):

**WRONG KIND OF INSTRUMENTATION:**

Considerable care must be given to the choice of instrumentation with regard to proper science support, with regard to crew and human factors considerations, and with regard to function in the unique environment of microgravity. Equipment which performs beautifully for you in ground-based experiments can be worthless in Spacelab. *Anecdotes:*

- Autogenic Feedback Training - Pack was bulky and got in the way; was not worn as scheduled.
- Cell Culture System - Cells adhered poorly; fluid shear displaced cells.
- KC-135 Flights - Provides ability to validate microgravity concepts with short-duration parabolas.

**PROPER INSTRUMENTATION:**

Non-existent state we all strive to obtain. *Anecdotes:*

- Future Hardware?





AMES RESEARCH CENTER  
SPACE LIFE SCIENCES PAYLOADS OFFICE



<b>NAME/ORG:</b> P. X. CALLAHAN	<b>TITLE:</b> CELLS II CONFERENCE	<b>DATE</b> 10/31/88
------------------------------------	--------------------------------------	-------------------------

PAYLOAD DEVELOPMENT APPROACH AT AMES RESEARCH CENTER

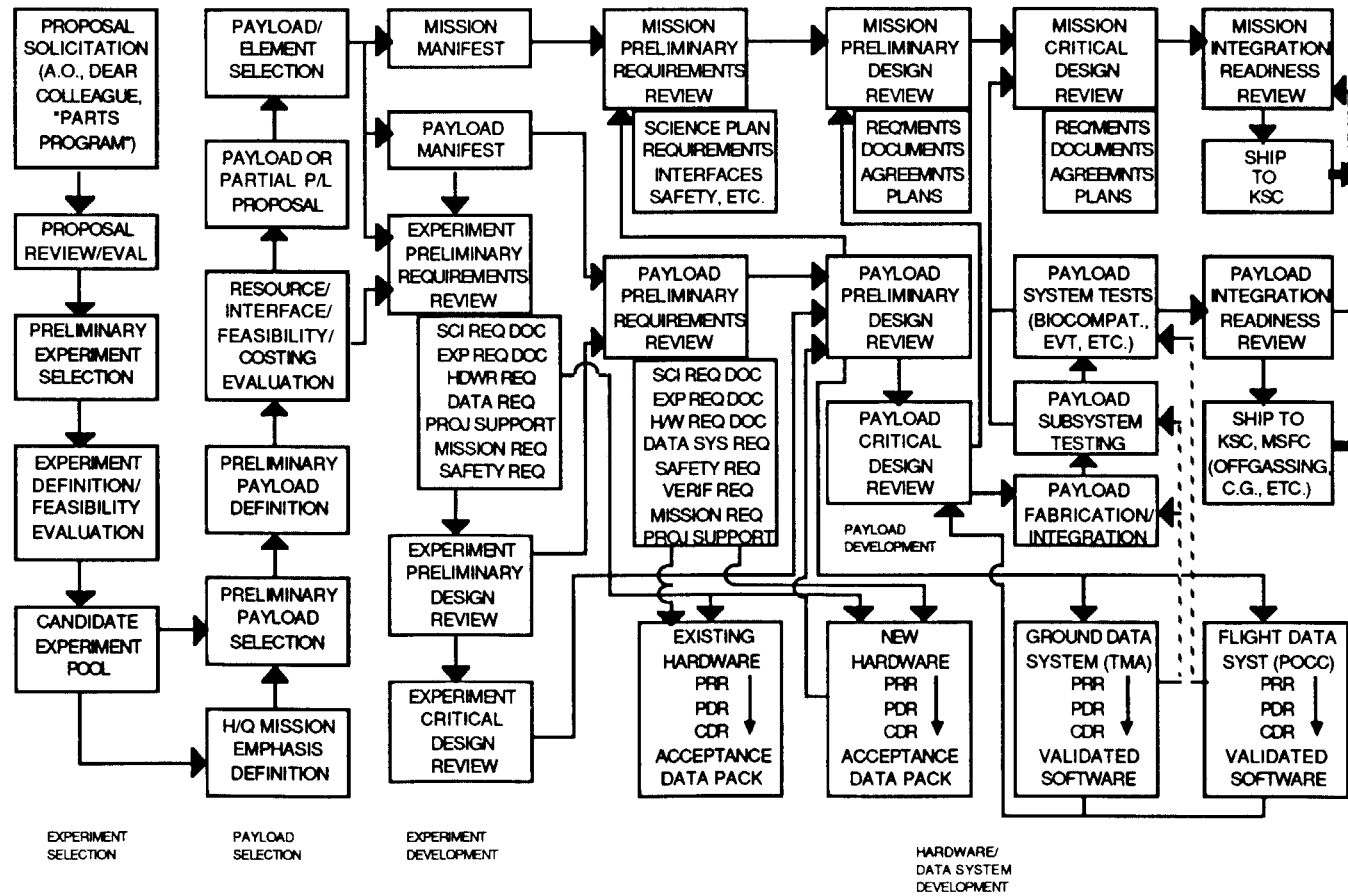



AMES RESEARCH CENTER  
SPACE LIFE SCIENCES PAYLOADS OFFICE



NAME/ORG:  
P. X. CALLAHAN

TITLE:  
CELLS II CONFERENCE

DATE  
10/31/88

MISSION APPROACH FOR AMES RESEARCH CENTER PAYLOADS

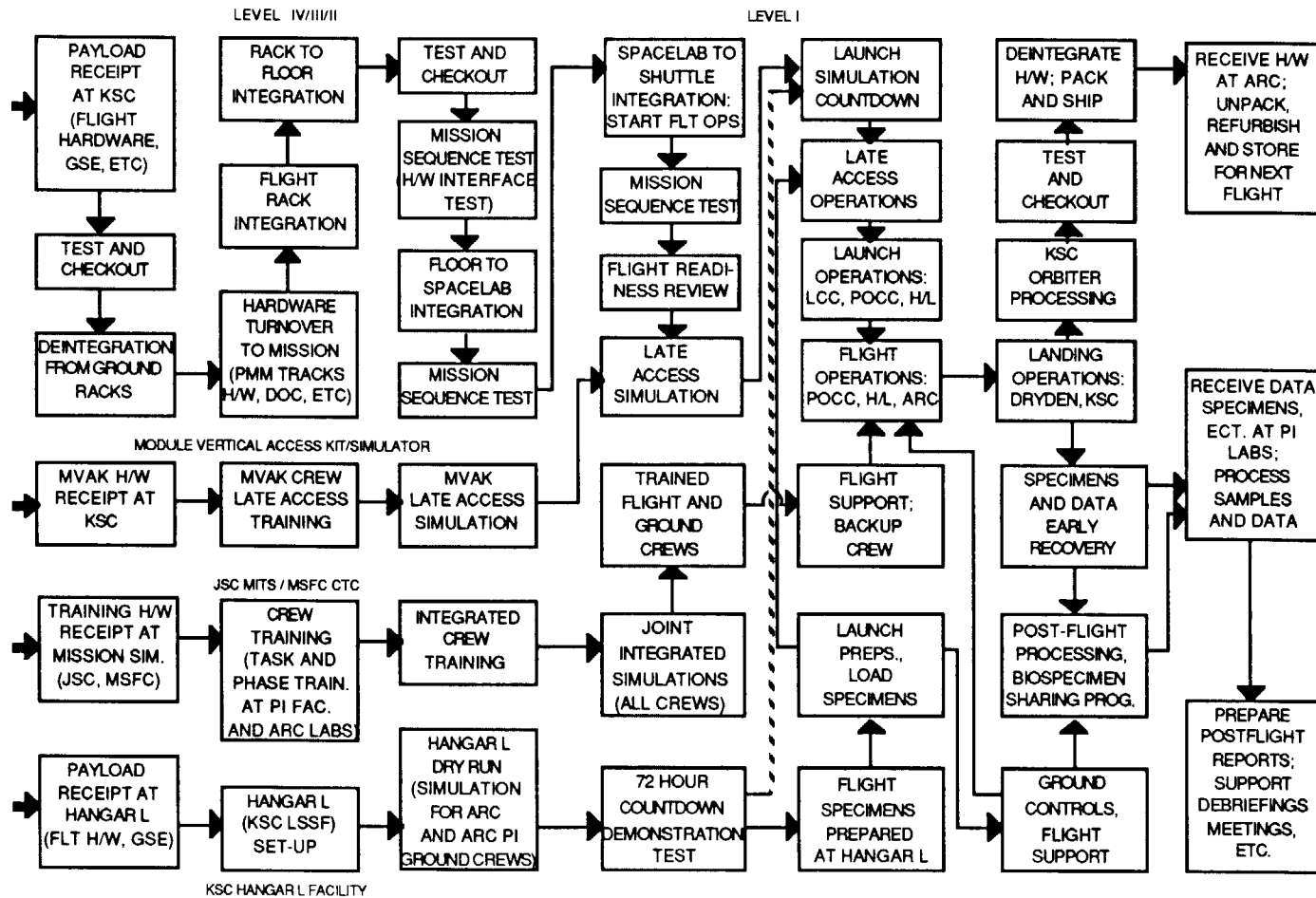



AMES RESEARCH CENTER  
SPACE LIFE SCIENCES PAYLOADS OFFICE

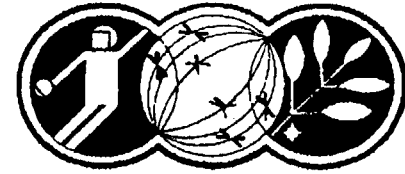

NAME/ORG:  
P. X. CALLAHAN

TITLE:  
CELLS II CONFERENCE

DATE  
10/31/88

VERIFICATION/TEST APPROACH AT AMES RESEARCH CENTER

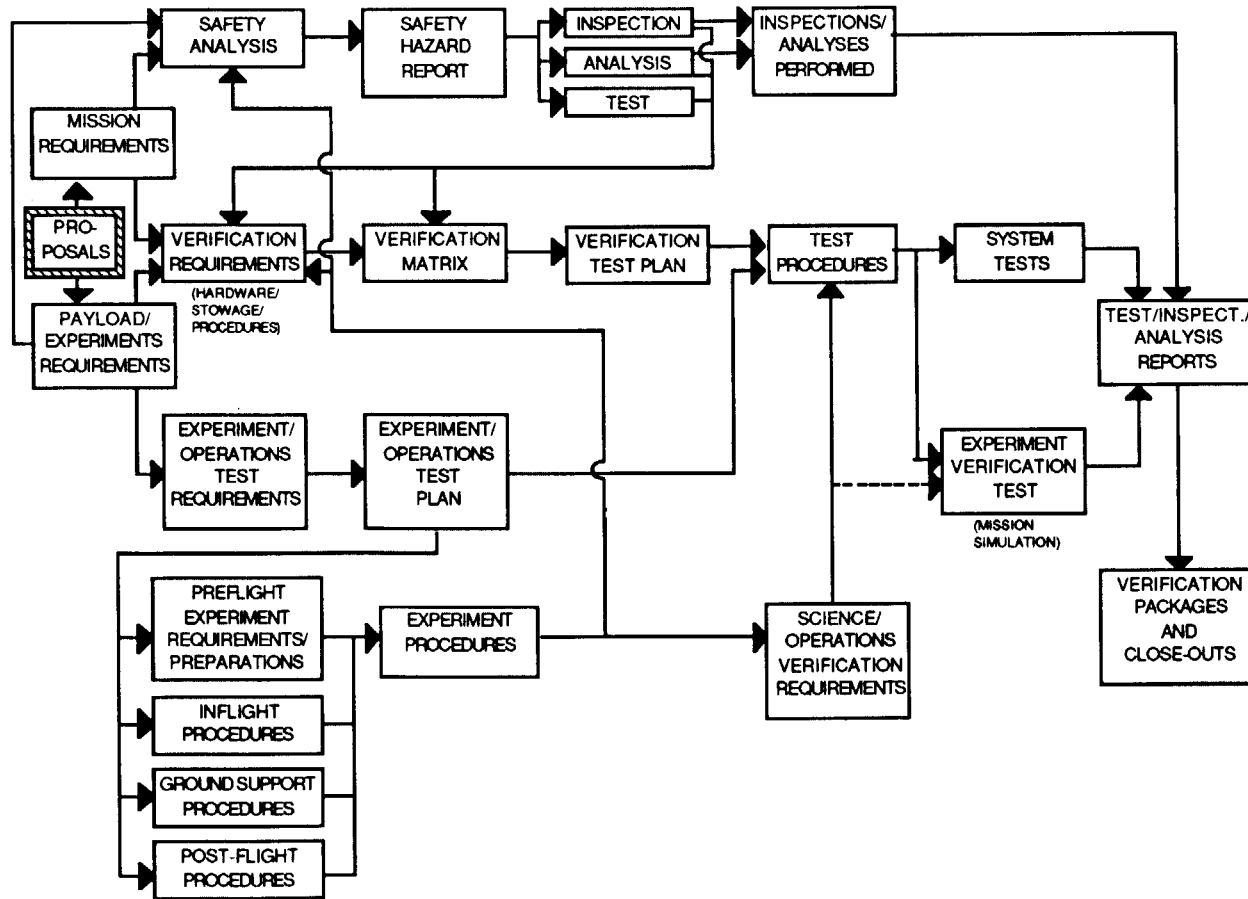

**RODNEY W. BALLARD/SP**

**CELLS IN SPACE-II CONFERENCE**

**11/2/88**

**LIMITATIONS ON SCIENCE  
DUE TO  
MISSION CONSTRAINTS**

**RODNEY W. BALLARD, Ph.D.**

**NASA ARC**

## LATE/EARLY ACCESS

- LATE LOADING --
  - 18 TO 24 HOURS PRIOR TO LAUNCH
  - THIS MEANS AS MUCH AS 54 HOURS FROM LOADING TO SPACELAB ACCESS
  
- EARLY UNLOADING
  - 2 TO 4 HOURS AFTER LANDING
  - STS IS TALKING 24 HOURS FOR SAFETY REASONS
  
- ASCENT AND DESCENT
  - DATA ACQUISITION IS ALMOST IMPOSSIBLE
  - ELECTRICAL POWER IS VERY LIMITED
  - NO ACCESS POSSIBLE

## CREW TIME

- LITTLE CREW TIME IS AVAILABLE FOR AN INDIVIDUAL EXPERIMENT
  - SELF-CONTAINED AND AUTOMATED EXPERIMENTS ARE ENCOURAGED
  - TELESCIENCE MAY OR MAY NOT BE AN ANSWER
  
- CREW MEMBER MAY NOT BE A SPECIALIST IN YOUR DISCIPLINE
  - CREW TRAINING IS ESSENTIAL
  - SIMPLE AND FOOLPROOF PROCEDURES YIELD THE BEST RESULTS
  - IF A HARDWARE FAILURE OCCURS, SIMPLE HARDWARE IS EASIEST TO FIX
  
- SAFETY IN SPACELAB IS ALL IMPORTANT
  - RADIOISOTOPES AND OTHER TOXIC MATERIALS MUST BE TRIPLE CONTAINED
  - SPECIAL FAILURE MODE ANALYSIS MAY BE REQUIRED
  - LIMITS ON TOXIC MATERIALS REGARDLESS OF CONTAINMENT

## MISSION DURATION

- **MISSION LENGTH SHOULD MATCH THE SCIENCE OBJECTIVES**
  - **STS MISSIONS WILL BE FROM 4 - 16 DAYS**
    - \* **ALL MID DECK OPPORTUNITIES ARE NOT THE SAME!**
  - **SPACELAB MISSIONS ARE TENDING TOWARD LONGER DURATIONS**
    - \* **THIS IS GOOD FOR CREW TIME, BUT NOT IF HARDWARE, CONSUMABLES OR SPECIMENS ARE NOT DESIGNED FOR THE MISSION LENGTH**
  - **LONGER MISSIONS MEAN EVEN MORE POWER RESTRAINTS**
    - \* **EVEN SHORT PERIODS OF HEAVY POWER MAY NOT BE ACCOMMODATED**

## GENERAL CONSTRAINTS

- LIMITED OPPORTUNITY FOR REPEAT EXPERIMENTS
- WEIGHT AND VOLUME RESTRICTIONS MEAN THAT THE LARGER THE ORGANISM THE SMALLER THE "N"
- BIOINSTRUMENTATION
  - IMPLANTS MUST BE DEMONSTRATED FOR SEVERAL MONTHS NOT JUST DURATION OF MISSION
  - DATA TRANSFER AND PROCESSING MAY BE LIMITING
  - WITH LIMITED NUMBERS OF SPECIMENS, HARDWARE FAILURES ARE MAGNIFIED





AMES RESEARCH CENTER  
SPACE LIFE SCIENCES PAYLOADS OFFICE



NAME/ORG: LASHBROOK / SLSPO	TITLE: CELLS II - MISSION REQUIREMENTS AND CONSTRAINTS ON EXPERIMENT HARDWARE	DATE: 10/31 - 11/4/88
--------------------------------	--	--------------------------

PHOTOGRAPH BY NASA AND FILMED

CELLS II:  
MISSION  
REQUIREMENTS AND CONSTRAINTS  
ON EXPERIMENT  
HARDWARE



AMES RESEARCH CENTER  
SPACE LIFE SCIENCES PAYLOADS OFFICE



<b>NAME/ORG:</b> LASHBROOK / SLSPO	<b>TITLE:</b> CELLS II - MISSION REQUIREMENTS AND CONSTRAINTS ON EXPERIMENT HARDWARE	<b>DATE:</b> 10/31 - 11/4/88
---------------------------------------	---	---------------------------------

### MISSION CONSTRAINTS ON HARDWARE DESIGN

#### - ABSTRACT -

A summary of Mission requirements is presented, including physical, safety and operational constraints. A list of documentation and formal reviews is presented. The effects of hardware and operational changes are described.



AMES RESEARCH CENTER  
SPACE LIFE SCIENCES PAYLOADS OFFICE

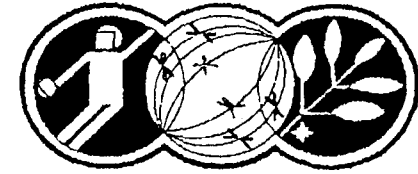

**NAME/ORG:**  
LASHBROOK / SLSPO

**TITLE:** CELLS II - MISSION REQUIREMENTS AND  
CONSTRAINTS ON EXPERIMENT HARDWARE

**DATE:**  
10/31 - 11/4/88

### MISSION CONSTRAINTS ON HARDWARE DESIGN

In addition to the scientific and performance requirements imposed by the Principal Investigator the hardware must meet various Mission requirements.

These mission requirements are imposed to protect the crew, the orbiter and other flight experiments on the same mission.

In addition to requirements imposed on the flight hardware, similar and in some cases identical requirements are imposed for hardware used in flight concurrent ground studies (Hangar L) and on ground support hardware used in conjunction with flight hardware.

This is by no means a complete listing of mission requirements, it is intended to give the experiment / hardware developer an inkling of what to expect. Many capable people are available to the Scientist and Hardware Developer to assist in the design, fabrication and documentation process necessary to qualify and fly experiment hardware.



AMES RESEARCH CENTER  
SPACE LIFE SCIENCES PAYLOADS OFFICE



NAME/ORG:  
LASHBROOK / SLSP0

TITLE: CELLS II - MISSION REQUIREMENTS AND  
CONSTRAINTS ON EXPERIMENT HARDWARE

DATE:  
10/31 - 11/4/88

## I PHYSICAL CONSTRAINTS

### A. SIZE, SHAPE, VOLUME, MASS DISTRIBUTION

\* MUST FIT INTO ASSIGNED ENVELOPE

- SINGLE OR DOUBLE RACK
- MID-DECK LOCKER
- STOWAGE LOCKER
- ETC.

### B. MASS LIMITS

- \* RACK STRUCTURAL LIMITATIONS
- \* RACK DICTATED LIMITS FOR LOCATION OF CENTER OF GRAVITY



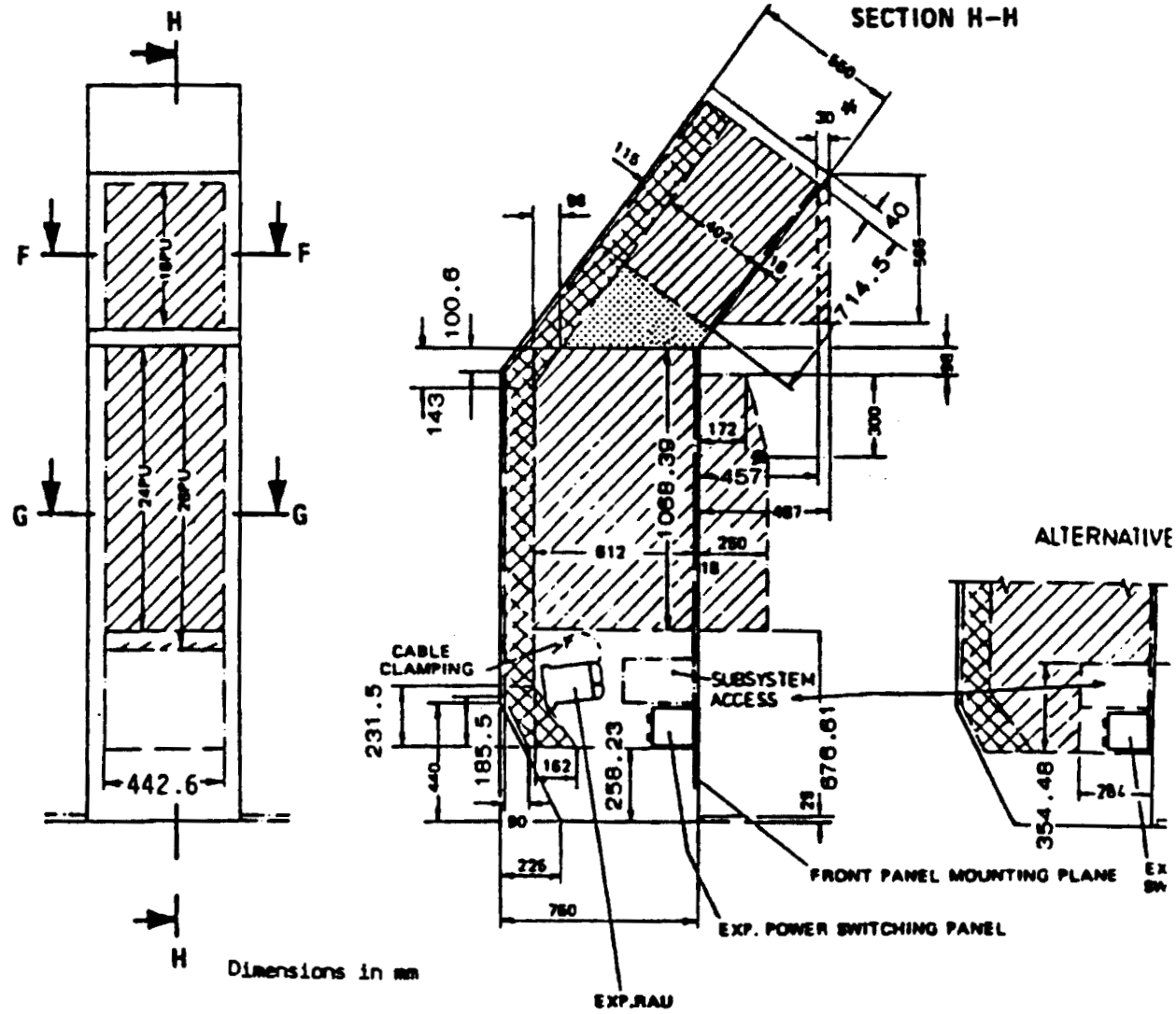

SINGLE RACK ENVELOPE

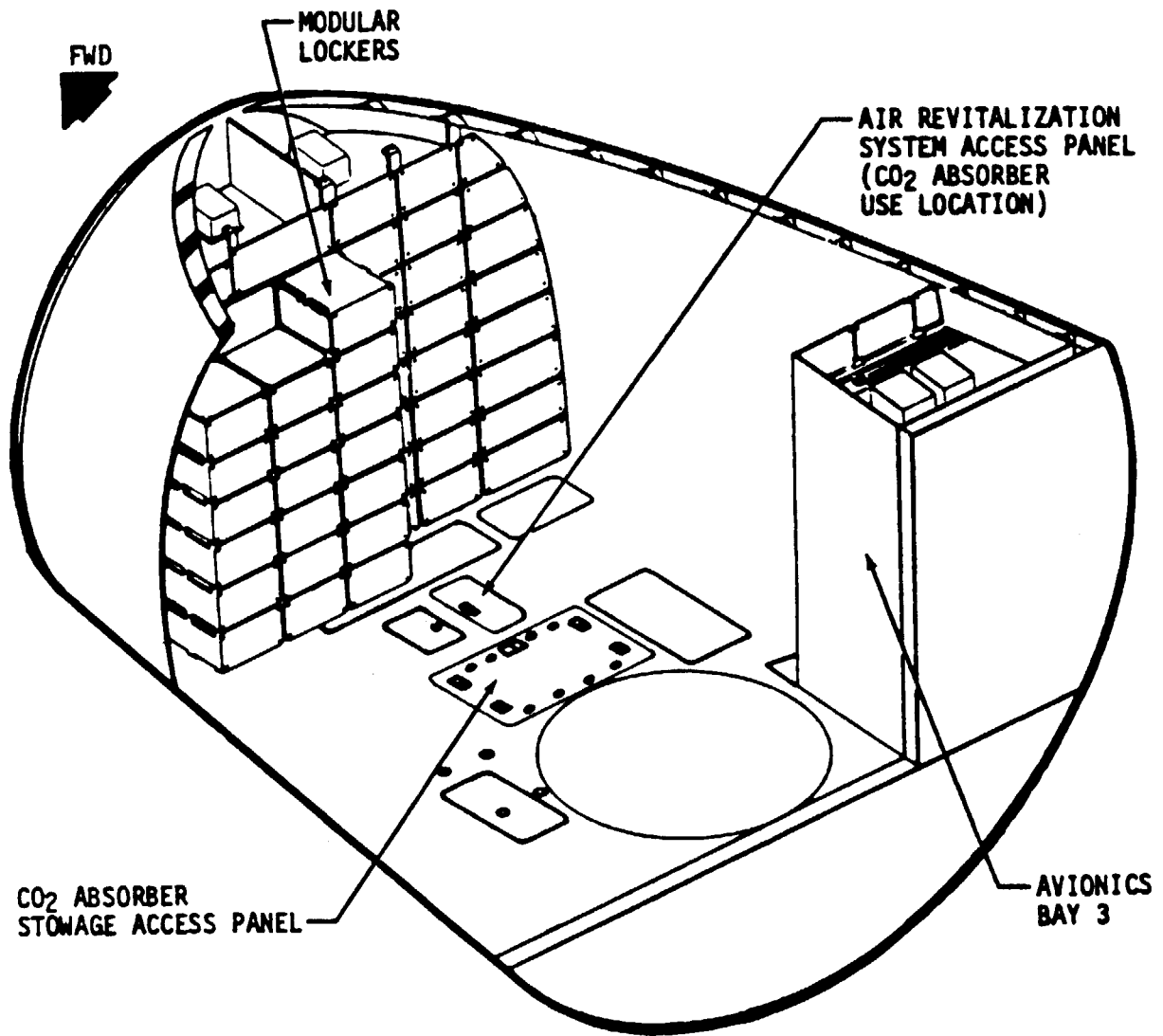

MIDDECK LOCKERS



NAME/ORG:  
LASHBROOK / SLSP0

TITLE: CELLS II - MISSION REQUIREMENTS AND  
CONSTRAINTS ON EXPERIMENT HARDWARE

DATE:  
10/31 - 11/4/88

### C. HARDWARE STRUCTURAL CAPABILITY

- \* HARDWARE MUST BE CAPABLE OF WITHSTANDING THE LAUNCH AND RECOVERY LOADS.
  - ANALYSIS AND TEST DATA MUST DEMONSTRATE THAT THE AS-BUILT HARDWARE'S STRUCTURAL CAPABILITY EXCEEDS THESE LOADS BY A POSITIVE MARGIN
- \* THE HARDWARE MUST BE CAPABLE OF WITHSTANDING ALL LOADS THAT MAY BE IMPOSED DURING TRANSPORT, OPERATION, ASSEMBLY, DISASSEMBLY AND STOWAGE
  - THE HARDWARE MUST BE CAPABLE OF WITHSTANDING ALL CREW-APPLIED LOADS.
    - LOADS EXPERIENCED DURING HARDWARE USE
    - INADVERTENTLY IMPOSED LOADS
      - "KICK-OFF" LOADS
      - HARDWARE FIXED TO IMMOVABLE STRUCTURES
  - LOADS IMPOSED BY TETHERS DURING ORBITER ACCELERATION / DECELERATION





<b>NAME/ORG:</b> LASHBROOK / SLSP0	<b>TITLE:</b> CELLS II - MISSION REQUIREMENTS AND CONSTRAINTS ON EXPERIMENT HARDWARE	<b>DATE:</b> 10/31 - 11/4/88
---------------------------------------	---	---------------------------------

C. STRUCTURAL CAPABILITY (continued)

- \* THE HARDWARE MUST BE CAPABLE OF WITHSTANDING THE PRESSURES DEVELOPED WITHIN THE HARDWARE DUE TO SPACELAB DEPRESSURIZATION / REPRESSURIZATION
  - DEPRESSURIZATION / REPRESSURIZATION CURVE IS SPECIFIED IN THE SPACELAB ACCOMMODATIONS HANDBOOK (SPAH)

II SAFETY

A. FLAMMABILITY, FLAME PROPAGATION, COMBUSTION PRODUCTS  
TOXICITY

- \* OFF-GASSING CONSTITUENTS

B. CONTAMINATION OF THE SPACELAB ENVIRONMENT

- \* LIQUIDS
  - FIXATIVES
  - GROWTH MEDIA
  - EXPERIMENT LIQUID WASTE
- \* SOLIDS, PARTICULATE MATTER
  - SOIL
  - FOOD BAR PARTICLES
  - EXPERIMENT SOLID WASTE



<b>NAME/ORG:</b> LASHBROOK / SLSP0	<b>TITLE:</b> CELLS II - MISSION REQUIREMENTS AND CONSTRAINTS ON EXPERIMENT HARDWARE	<b>DATE:</b> 10/31 - 11/4/88
---------------------------------------	---	---------------------------------

SAFETY (continued)

C. BIOHAZARDS

- \* RADIOACTIVE TRACERS
- \* CARCINOGENS
- \* TOXIC SUBSTANCES

D. ELECTRICAL SHOCK

- \* ANALYSIS AND TEST DATA MUST DEMONSTRATE THE ELECTRICAL SAFETY OF THE HARDWARE

E. EMI

- \*ELECTROMAGNETIC INFLUENCES ON THE ORBITER AND OTHER EXPERIMENTS IS NOT PERMITTED.
  - ANALYSIS AND TEST DATA MUST DEMONSTRATE THAT THE HARDWARE DOES NOT RADIATE EMI BEYOND SPECIFIED, ACCEPTABLE LIMITS.

F. CREW INTERFACES

- \* SHARP EDGES
- \* LATCH DESIGN
  - PINCHED FINGERS
  - BUSTED KNUCKLES
  - HUMAN FACTORS

252



AMES RESEARCH CENTER  
SPACE LIFE SCIENCES PAYLOADS OFFICE

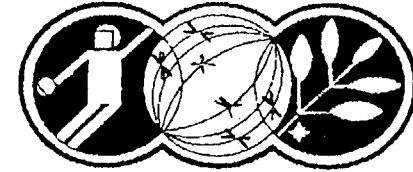

<b>NAME/ORG:</b> LASHBROOK / SLSP0	<b>TITLE:</b> CELLS II - MISSION REQUIREMENTS AND CONSTRAINTS ON EXPERIMENT HARDWARE	<b>DATE:</b> 10/31 - 11/4/88
---------------------------------------	---	---------------------------------

III OPERATIONAL CONSTRAINTS

A. PRE-LAUNCH PREPARATIONS

- \* EXPERIMENT PREPARATION FOR LOADING, INCLUDING GROUND STUDIES, FLIGHT BACK-UPS
  - MINIMIZE LAST-MINUTE COMPLEXITY
  - MINIMIZE LAST MINUTE WORKLOAD
  - MINIMIZE NEED FOR COMPLEX LAB SUPPORT / HUMAN RESOURCES.
  
- \* LATE ACCESS:      BEGINS AT LAUNCH MINUS 50 HOURS      (MAY CHANGE)  
   ENDS AT LAUNCH MINUS 13 HOURS
  - MINIMIZE PERISHABLE / CONSUMABLE EXPERIMENT CONTENT
  - MINIMIZE ENVIRONMENTAL CONTROLS NEEDED DURING LATE ACCESS LOADING
    - CARRY-ON CONTAINERS
  
  - MINIMIZE ENVIRONMENTAL CONTROLS NEEDED AFTER LOADING AND PRIOR TO POST-LAUNCH EXPERIMENT STARTUP

253



<b>NAME/ORG:</b> LASHBROOK / SLSP0	<b>TITLE:</b> CELLS II - MISSION REQUIREMENTS AND CONSTRAINTS ON EXPERIMENT HARDWARE	<b>DATE:</b> 10/31 - 11/4/88
---------------------------------------	---	---------------------------------

III OPERATIONAL CONSTRAINTS (continued)

A. PRE-LAUNCH (continued)

- ORBITER / SPACELAB IN VERTICAL POSITION
  - PERSONNEL PERFORMING LATE ACCESS LOADING ARE LOWERED INTO SPACELAB BY BOSUN'S CHAIR
    - LATE ACCESS ITEMS SIZE LIMITED ACCORDINGLY
    - MASS IS LIMITED
    - COMPLEXITY OF LOADING OPERATION IS LIMITED
    - MAN ON THE FLYING TRAPEZE.
- POST EXPERIMENT LOADING, PRE-LAUNCH OPERATIONS (ON THE PAD TIME)
  - VERY LIMITED UTILITIES AVAILABLE
  - VERY LIMITED DATA EXCHANGE CAPABILITY
    - EXPERIMENT SHOULD TAKE CARE OF ANY REQUIRED DATA ACQUISITION AND STORAGE.
  - LIMITED ENVIRONMENTAL CONTROLS
  - NO CREW INTERACTION WITH THE EXPERIMENT



<b>NAME/ORG:</b> LASHBROOK / SLSPO	<b>TITLE:</b> CELLS II - MISSION REQUIREMENTS AND CONSTRAINTS ON EXPERIMENT HARDWARE	<b>DATE:</b> 10/31 - 11/4/88
---------------------------------------	---	---------------------------------

### III OPERATIONAL CONSTRAINTS (continued)

#### A. PRE-LAUNCH (continued)

- LAUNCH DELAY
  - EXPERIMENT MUST ACCOMMODATE MAXIMUM LAUNCH HOLD WITHOUT REQUIRING SERVICES - 24 MAXIMUM DELAY
- LAUNCH RESCHEDULE
  - REPLACE/REFURBISH/REPLENISH CAPABILITY
    - MUST BE READY TO FLY AGAIN WITHIN 72 HOURS

#### B. IN-FLIGHT

- SPACELAB / ORBITER CLOSED ENVIRONMENT
  - LIMITED HEAT REMOVAL CAPABILITY
  - LIMITED ELECTRICAL POWER CAPACITY
    - ALLOW FOR CONTINGENCIES
  - LIMITED 'GARBAGE' VOLUME AVAILABLE
    - WHAT GOES UP MUST COME DOWN



<b>NAME/ORG:</b> LASHBROOK / SLSP0	<b>TITLE:</b> CELLS II - MISSION REQUIREMENTS AND CONSTRAINTS ON EXPERIMENT HARDWARE	<b>DATE:</b> 10/31 - 11/4/88
---------------------------------------	---	---------------------------------

### III OPERATIONAL CONSTRAINTS (continued)

#### B. IN-FLIGHT (continued)

- NON GRAVITY ACCELERATIONS
  - ORBITER MANEUVERING/ATTITUDE CONTROL
    - RANDOM VECTORS
    - LIMITED SCIENCE CONTROL
      - MAKE NEEDS KNOWN EARLY ON
      - FACTOR INTO EXPERIMENT TIME-LINE
  - CREW IMPOSED ACCELERATIONS
    - VIBRATION
    - ADJACENT DOOR/DRAWER CLOSURE
    - INADVERTANT CREW IMPACT WITH HARDWARE
- ORBITAL INCLINATION
  - MISSION SPECIFIC
  - MANIFEST IN ACCORDANCE WITH EXPERIMENT REQUIREMENTS



AMES RESEARCH CENTER  
SPACE LIFE SCIENCES PAYLOADS OFFICE



<b>NAME/ORG:</b> LASHBROOK / SLSP0	<b>TITLE:</b> CELLS II - MISSION REQUIREMENTS AND CONSTRAINTS ON EXPERIMENT HARDWARE	<b>DATE:</b> 10/31 - 11/4/88
---------------------------------------	---	---------------------------------

III OPERATIONAL CONSTRAINTS (continued)

B. IN-FLIGHT (continued)

- FIRST CREW ACCESS TO SPACELAB IS LAUNCH + 6 HOURS
- LIMITED CREW TIME (60% FIRST DAY, 75% THEREAFTER)
  - USER FRIENDLY HARDWARE MAXIMIZES CREW PRODUCTIVITY
    - MINIMIZE ON-ORBIT COMPLEXITY
    - BDA
    - MINIMIZE THE NUMBER OF CREW OPERATIONS
    - MAXIMIZE EXPERIMENT SELF-SUFICIENCY
      - OPERATION
      - DATA COLLECTION / CREW OBSERVATION
  - SEVERELY LIMITED ON-ORBIT REPAIR CAPABILITY
    - FEW TOOLS OR STOWAGE VOLUME FOR THEM
    - SEVERELY LIMITED TIME AVAILABLE FOR CREW/GROND INTERACTIVE DIAGNOSIS
      - COMPLETE MALFUNCTION PROCEDURES ESSENTIAL
      - NO "BEAM ME UP SCOTTY" CAPABILITY AVAILABLE AT THIS TIME
- THE BOTTOM LINE:
  - ON-ORBIT OPERATIONAL SIMPLICITY AT THE EXPENSE OF PRE-FLIGHT COMPLEXITY IS A GOOD TRADE-OFF
  - SIMPLICITY - SIMPLICITY - SIMPLICITY

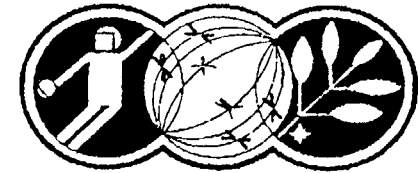

<b>NAME/ORG:</b> LASHBROOK / SLSP0	<b>TITLE:</b> CELLS II - MISSION REQUIREMENTS AND CONSTRAINTS ON EXPERIMENT HARDWARE	<b>DATE:</b> 10/31 - 11/4/88
---------------------------------------	---	---------------------------------

### III OPERATIONAL CONSTRAINTS (continued)

- C. POST FLIGHT
- RECOVERY TIMES
  - PRIME LANDING SITES
    - KSC
    - DRYDEN
      - 3 HOUR MINIMUM WAIT FOR ACCESS TO THE EXPERIMENTS
      - LIKELY TO INCREASE TO 24 HOURS PLUS
        - NO CREW INTERACTION
        - LIMITED UTILITIES
        - PROVIDE / SPECIFY NEEDED RECOVERY CONTROLS
          - ENVIRONMENTAL
          - ORIENTATION CONTROLS / SPECIAL HANDLING
          - MINIMIZE TIME-CRITICAL OPERATIONS
  - CONTINGENCY LANDING SITES
    - LENGTHY RECOVERY DELAYS
    - VERY LIMITED GROUND CREW / ORBITER SERVICING EQUIPMENT AVAILABLE
      - PROVIDE CONTINGENCY PLANS/PROCEDURES TO MITIGATE SCIENCE LOSS



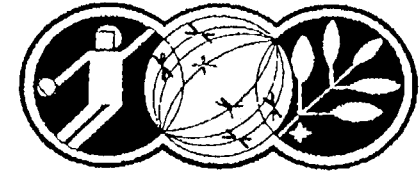

<b>NAME/ORG:</b> LASHBROOK / SLSP0	<b>TITLE:</b> CELLS II - MISSION REQUIREMENTS AND CONSTRAINTS ON EXPERIMENT HARDWARE	<b>DATE:</b> 10/31 - 11/4/88
---------------------------------------	---	---------------------------------

#### IV DOCUMENTATION REQUIREMENTS

- DOCUMENTATION MATURITY:
  - PRELIMINARY DESIGN REVIEW (PDR)
    - HARDWARE PERFORMANCE REQUIREMENTS FROZEN /BASE-LINED
    - HARDWARE CONCEPTS ESTABLISHED
    - PRELIMINARY DRAWINGS COMPLETED AFTER INCORPORATION OF PDR COMMENTS
    - PERMISSION TO PROCEED AS BASELINED GRANTED
    - FINAL DESIGN AND DOCUMENTATION GENERATION STARTED
  - CRITICAL DESIGN REVIEW (CDR)
    - BUILD-TO DRAWINGS REVIEWED AND APPROVED
    - DESIGNS REVIEWED AND ACCEPTED
    - DESIGN IS BASELINED
    - DRAWINGS FROZEN FOLLOWING INCORPORATION OF CDR COMMENTS
    - CHANGE CONTROL INVOKED
      - CHANGES FROM THIS POINT REQUIRE CHANGE CONTROL BOARD APPROVAL
    - PERMISSION TO PROCEED WITH HARDWARE FABRICATION GRANTED
    - PAYLOAD DOCUMENTATION UPDATED



AMES RESEARCH CENTER  
SPACE LIFE SCIENCES PAYLOADS OFFICE

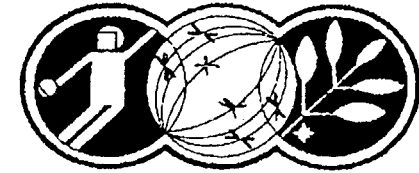

NAME/ORG:  
LASHBROOK / SLSPO

TITLE: CELLS II - MISSION REQUIREMENTS AND  
CONSTRAINTS ON EXPERIMENT HARDWARE

DATE:  
10/31 - 11/4/88

#### IV DOCUMENTATION REQUIREMENTS (continued)

- INTEGRATED PAYLOAD CRITICAL DESIGN REVIEW
  - MISSION PAYLOAD IS BASELINED
    - POST IPL/CDR CHANGES IMPACT:
      - GROUND INTEGRATION REQUIREMENTS DOCUMENT
      - INSTRUMENT INTERFACE AGREEMENT
      - OPERATIONS AND INTEGRATION AGREEMENT
      - INTEGRATED PAYLOAD REQUIREMENTS DOCUMENT
      - EXPERIMENT REQUIREMENTS SIMULATION DOCUMENTATION
      - STOWAGE LIST
      - MANY OTHER DOCUMENTS
        - TEST PROCEDURES
        - STOWAGE DRAWINGS
        - MASS PROPERTIES REPORTS
        - ENGINEERING DRAWINGS
        - MATERIALS USAGE LIST
- GENERAL RULE : THE LATER A CHANGE IS REQUESTED THE LESS CHANCE THE CHANGE HAS OF BEING APPROVED.



AMES RESEARCH CENTER  
SPACE LIFE SCIENCES PAYLOADS OFFICE

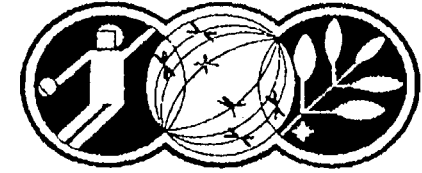

<b>NAME/ORG:</b> LASHBROOK / SLSPO	<b>TITLE:</b> CELLS II - MISSION REQUIREMENTS AND CONSTRAINTS ON EXPERIMENT HARDWARE	<b>DATE:</b> 10/31 - 11/4/88
---------------------------------------	---	---------------------------------

## SUMMARY

THE MAJOR CONSTRAINTS CAN BE GROUPED AND CLASSIFIED AS FOLLOWS:

1. PHYSICAL CONSTRAINTS  
HOW BIG  
HOW HEAVY  
HOW MANY RESOURCES ARE NEEDED
2. SAFETY CONSTRAINTS  
DOCUMENTATION AND TESTING MUST ASSURE THAT NO HARM WILL COME TO  
THE CREW OR ORBITER UNDER ANY FAILURE MODE.
3. OPERATIONAL CONSTRAINTS  
THE CREW HAS LIMITED TIME, AND RESOURCES AND IS OPERATING UNDER  
UNUSUAL CONDITIONS. (MICRO G)
4. DOCUMENTATION CONSTRAINTS  
FINALIZE REQUIREMENTS AS SOON AS POSSIBLE  
FINALIZE DOCUMENTATION AS SOON AS POSSIBLE

---

THE BOTTOM LINE: KEEP HARDWARE SMALL, LIGHT, MINIMIZE COOLING AND POWER USE  
KEEP IT SIMPLE TO OPERATE AND MAKE IT AS SELF SUFFICIENT AS POSSIBLE

**PRECEDING PAGE BLANK NOT FILMED**

# **CELLS IN SPACE - II**

## **NOVEMBER 3, 1988**

**L.A. MILOV  
CHAIRMAN, COMMERCIAL LIFE SCIENCE WORKING GROUP**

# WORKING GROUP COMMERCIAL LIFE SCIENCE ADVOCACY FLOW DIAGRAM

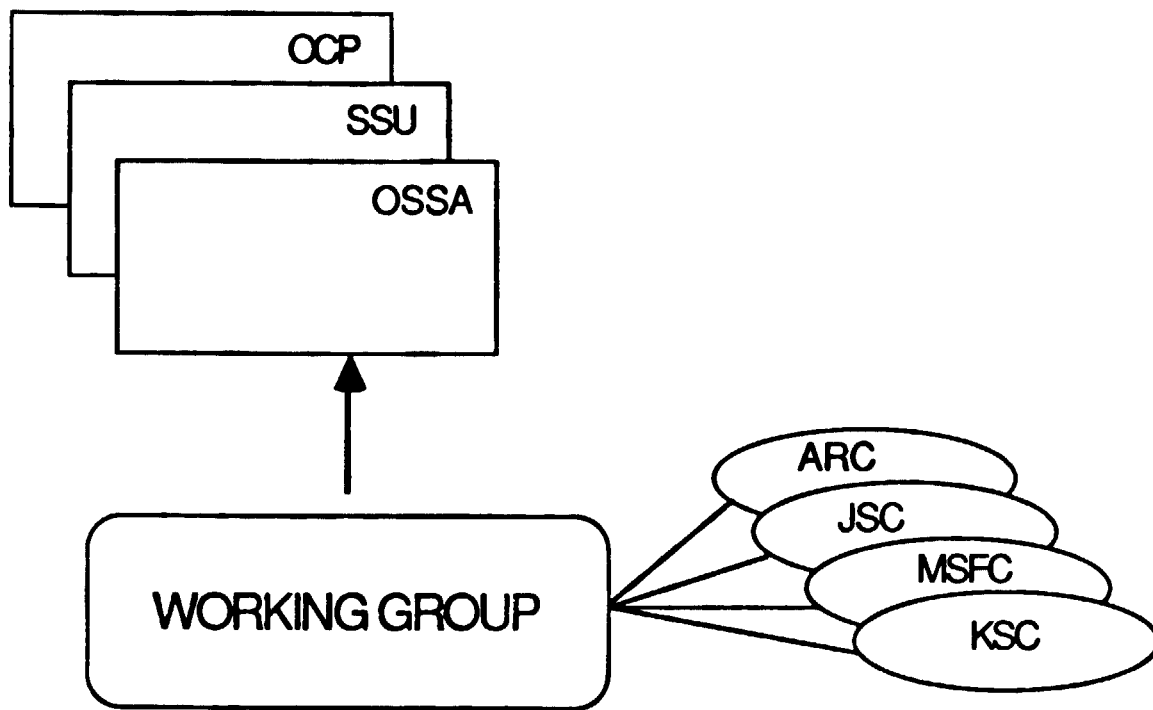

**INTERNAL**

**EXTERNAL**

**OUTREACH TEAM**

- Research Triangle Institute
- Boeing-Peat Marwick
- Center for Space and Advanced Technology

**CCDS**

- Bioserve Space Technologies
- Center for Cell Research (CCR)

**OTHER USERS**

- Industrial Applications Centers
- Individual Companies

**COMMERCIAL LIFE SCIENCE WORKING GROUP  
ADVOCACY FOCAL POINTS**

**Workshops**

**Background And Status**

- **Summer 1988 Workshop in California**
- **Fall 1988 Sub-Panel at Denver Space Station Workshop**
- **Winter 1988 Workshop at Kennedy Space Center**

**COMMERCIAL LIFE SCIENCE WORKING GROUP  
ADVOCACY FOCAL POINTS  
OVERVIEW**

- **Developing and Implementing A NASA Research Announcement in Commercial Life Sciences**
- **Getting More Mileage Out of Small Business Innovation Research Awards In Life Sciences**
- **Providing a Focus for Space Station Mission Requirements in Commercial Life Sciences**
- **Continuing to Support Commercial Life Science Workshops**

# COMMERCIAL LIFE SCIENCE WORKING GROUP ADVOCACY FOCAL POINTS

## NASA Research Announcement in Commercial Life Sciences

### Proposed Program Goal and Objectives

#### GOAL

Based on a partnership between OCP and the Life Sciences Division, use the NRA as a mechanism to stimulate commercial investment and involvement in ground and space-based life science initiatives which support NASA's long-term life sciences program goals.

#### OBJECTIVES

- Stimulate commercially-sponsored basic research in commercial life sciences
- Increase the profile of NASA's life science program with U.S. industry, and stimulate the number of opportunities for industry to exploit unique NASA expertise and facilities in life sciences
- Build upon the partnerships which have been established between NASA, industry and universities in life sciences (e.g. Centers for the Commercial Development of Space)
- Provide the life sciences program at NASA with greater feedback on commercial user requirements



**COMMERCIAL LIFE SCIENCE WORKING GROUP  
ADVOCACY FOCAL POINTS**

**NASA Research Announcement in Commercial Life Sciences**

**Background**

- **Jointly Funded (Code C/Code EE) NASA Research Announcement for the Remote Sensing Applications/Commercialization Program**
- **OCP New Initiatives Task Team Life Sciences Sub-Panel Recommendation in Support of NRA in Commercial Life Sciences**
- **Industry Workshops in Life Sciences Sponsored by the Commercial Life Sciences Working Group**

**COMMERCIAL LIFE SCIENCE WORKING GROUP  
ADVOCACY FOCAL POINTS**

**NASA Research Announcement in Commercial Life Sciences**

**Potential Research Areas**

- **Controlled Ecological Life Support Systems**
- **Biospherics**
- **Gravitational Biology**
- **Bioprocessing**
- **Biomedical Research**

**COMMERCIAL LIFE SCIENCE WORKING GROUP  
ADVOCACY FOCAL POINTS**

**Small Business Innovation Research**

**Background**

- **Inclusion of Commercial Life Sciences Sub-Topic in SBIR Solicitation**
- **Participation of Life Sciences CCDS' in SBIR Proposals**
- **OCP New Initiatives Task Team Recommendations to Strengthen SBIR Support of Commercial Life Sciences Initiatives**

**COMMERCIAL LIFE SCIENCE WORKING GROUP  
ADVOCACY FOCAL POINTS**

**Small Business Innovation Research**

**Objectives**

- **Implement OCP Task Team Life Sciences Sub-Panel Recommendations on Commercial Life Sciences:**
  - - **Incentivize SBIR Awardee Collaboration with Industry to Facilitate Transition to Phase III Funding;**
  
- **Increasing the Number of SBIR Awardees in Commercial Life Sciences**
  
- **Provide Dedicated SBIR Selection in Commercial Life Sciences At Each Field Center**

**COMMERCIAL LIFE SCIENCE WORKING GROUP  
ADVOCACY FOCAL POINTS**

**Serving As A Focus for Mission Requirements**

**Background And Status**

- **Commercial Life Sciences Working Group Originally Chartered as a Mechanisms for Generating Space Station Mission Requirements**
- **CLSWG Has Provided OCP (CD/Oran) With "Placeholder" Commercial Life Sciences Missions**
- **CLSWG Working With MSFC/Fountain to Input Commercial Life Science Requirements Into Space Station Payload Manifest**

## HERE WE GO ...

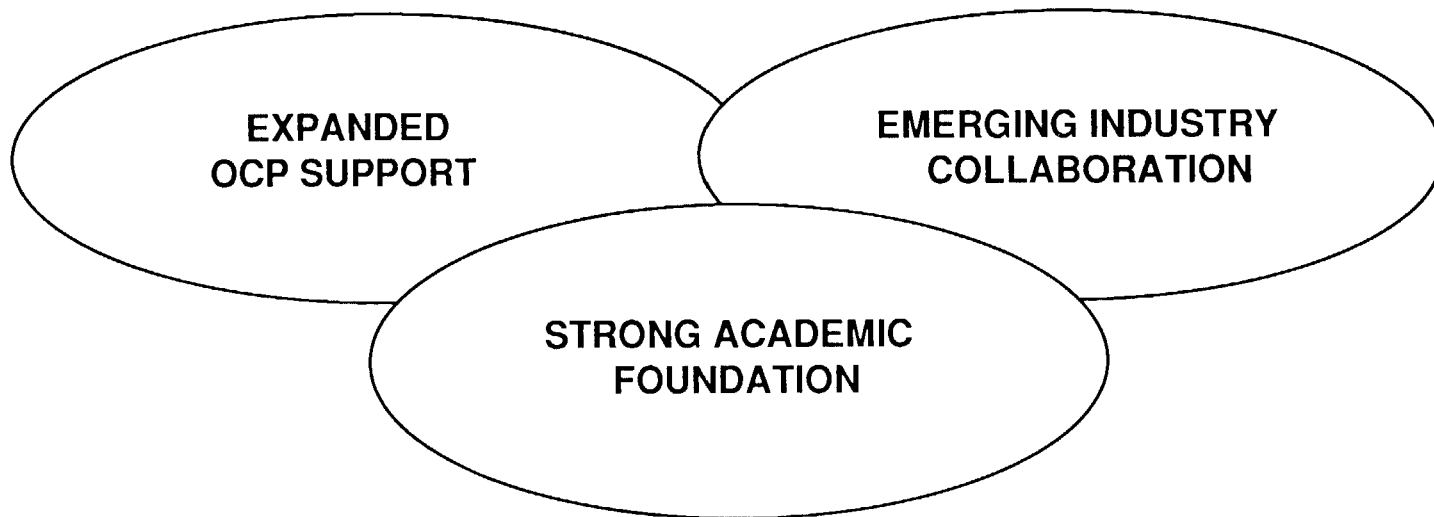

## ACCOMPLISHMENTS

- ORGANIZED COMMERCIAL LIFE SCIENCES WORKING GROUP
- FACILITATED SELECTION OF TWO CCDS IN LIFE SCIENCES
- CREATED COMMERCIAL LIFE SCIENCES SBIR SUB TOPIC
- IDENTIFIED COMMERCIAL LIFE SCIENCE INITIATIVES FOR OCP TASK TEAM
- FIRST COMMERCIAL LIFE SCIENCES SUB PANEL
  - 1988 SPACE STATION FREEDOM WORKSHOP

## PURPOSE OF SUB-PANEL

- DESCRIBE NASA'S LIFE SCIENCE PROGRAM AND POTENTIAL AREAS FOR COLLABORATION.
- DISCUSS MECHANISMS AVAILABLE FOR INDUSTRIAL COLLABORATION
- STIMULATE DIALOGUE ON HOW NASA CAN RESPOND TO INDUSTRY'S RESEARCH AGENDA IN LIFE SCIENCES



## **AMES SUPPORT FOR COMMERCIAL LIFE SCIENCE RESEARCH**

- **ACCESS TO NASA INVESTIGATORS AND FACILITIES**
  - **SCIENTISTS AND ENGINEERS PERFORMANCE EVALUATIONS**
  - **AGREEMENT MECHANISMS**
- **SMALL BUSINESS INNOVATION RESEARCH PROGRAM**
  - **SUB TOPIC ESTABLISHED**
  - **2 PHASE I AWARDS IN FY 88**
- **BIOSERVE, UNIVERSITY OF COLORADO BOULDER**
  - **CONTROLLED GRAVITY TECHNOLOGY, 1.8 METER CENTRIFUGE**
  - **MEMBER COMMERCIAL LIFE SCIENCE WORKING GROUP**
- **CENTER FOR CELL RESEARCH, PENN STATE**
  - **ANIMAL ENCLOSURE MODULE**
  - **MEMBER COMMERCIAL LIFE SCIENCE WORKING GROUP**
- **UNIVERSITY OF WISCONSIN, MADISON, WISCONSIN**

## PRELIMINARY LISTING OF CENTERS FOR THE COMMERCIAL DEVELOPMENT OF SPACE CORPORATE AFFILIATES

AMOCO CHEMICALS CORPORATION  
PPG INDUSTRIES, INC.  
ROCKWELL INTERNATIONAL  
E.I. DuPONT  
II-VI, INC.  
HERCULES  
BOEING AEROSPACE COMPANY  
FRONTIER RESEARCH  
DEERE AND COMPANY  
IBM ALMADEN  
MARTIN MARIETTA AEROSPACE  
McDONNELL DOUGLAS CORP.  
TELEDYNE BROWN ENGINEERING  
WYLE LABORATORIES  
MASSCOMP  
INTERNATIONAL PAPER  
SOIL TECH, INC.  
EXXON  
MURPHY OIL  
FREEPORT McMORAN  
APPLE COMPUTERS  
HARDING LAWSON & ASSOCIATES  
PALEN FARMS, INC.  
GEOSTAR, INC.  
VERSATEC  
PIONEER SEED COMPANY  
TENNECO OIL COMPANY  
BRITISH PETROLEUM  
FIRST NATIONAL BANK OF TONKAWA  
BANK OF WELLINGTON  
ASTRONAUTICS CORP. OF AMERICA  
AT&T  
SCHERING CORP.  
PROCTOR & GAMBLE  
DOW CHEMICALS  
SMITH, KLINE & BECKMAN  
ELI LILY  
MERCK, SHARPE & DOME  
UPJOHN  
EASTMAN KODAK

BIOCRYST  
ALCOA  
ARMCO, INC.  
ALLIED SIGNAL  
CABOT, CORP.  
ENGLEHARD CORP.  
GENERAL ELECTRIC  
GENERAL MOTORS  
GTE  
LOCKHEED  
GRUMMAN CORP.  
TRANS-TEMP  
WESTINGHOUSE  
DANTEC ELECTRONICS  
QUANTUM TECHNOLOGIES  
BARNES ENGINEERING  
SPACEHAB  
SPECTRON LABORATORIES  
ELECTRO-OPTEK  
PERKIN ELMER  
INSTRUMENTS S.A., INC.  
BEAVER DAM EMERGING GROWTH  
GAMMEX, INC.  
DELCO  
JOHNSON CONTROLS, INC.  
MADISON KIPP, INC.  
PHYTO FARMS OF AMERICA  
PIERSON PRODUCTS, INC.  
SILICON SENSORS  
SNAP-ON-TOOLS  
SUNDSTRAND CORP.  
SEVRAIN TECH, INC.  
AMERICAN ELECTRIC POWER COMPANY  
TRIMBLE NAVIGATION  
GAS RESEARCH INSTITUTE  
SYNERCOM, INC.  
DEC  
3M  
GOODYEAR  
TRW

EDISON POLYMER INNOVATION  
DOVAL COMPOSITES, INC.  
LeMONT SCIENTIFIC, COMPANY  
COULTER  
SUPELCO  
SCIENTIFIC SYSTEMS, INC.  
ZETACHRON  
MONOCLONAL PRODUCTION  
DIGENE  
SCIENTIFIC ENTERPRISES  
ELECTROPORE, INC.  
BEND RESEARCH  
GELMAN SCIENCES  
MICKLEY & ASSOCIATES  
PRECISION SCIENTIFIC  
BALL AEROSPACE  
ALZA  
MAXWELL LABORATORIES  
ROCKETDYNE  
SATURN CORP.  
SYMBOLICS, INC.  
TECHNION, INC.  
PEPCO  
GULF STATE UTILITIES  
ENTECH, INC.  
ARTHUR D. LITTLE  
FORD AEROSPACE  
SOLAR ENERGY RESEARCH INSTITUTE  
ELECTRIC POWER RESEARCH INSTITUTE  
COMSAT CORP.  
EAGLE PICHER, INC.  
E-SYSTEMS, INC.  
GENERAL DYNAMICS  
ELECTROCHEM, INC.  
FAIRCHILD  
KMS FUSION  
GEOSPECTRA, INC.  
DUPERON, INC.  
INVITRON

119 CORPORATE

## CENTERS FOR THE COMMERCIAL DEVELOPMENT OF SPACE UNIVERSITY AFFILIATES

32 = UNIVERSITIES

AKRON UNIVERSITY  
CASE WESTERN RESERVE UNIVERSITY  
CLARKSON UNIVERSITY  
CLEVELAND UNIVERSITY  
OHIO STATE UNIVERSITY  
WASHINGTON STATE UNIVERSITY  
WORCESTER POLYTECHNIC  
UNIVERSITY OF MAINE  
MURRAY STATE UNIVERSITY  
FLORIDA STATE UNIVERSITY  
MONTANA STATE UNIVERSITY  
UNIVERSITY OF SOUTHERN MISSISSIPPI  
PURDUE UNIVERSITY  
UNIVERSITY OF ALABAMA - HUNTSVILLE  
UNIVERSITY OF ALABAMA - TUSCALOOSA  
UNIVERSITY OF FLORIDA - GAINESVILLE

ALABAMA A&M UNIVERSITY  
UNIVERSITY OF FLORIDA  
RENSELAER POLYTECHNIC INSTITUTE  
UNIVERSITY OF ILLINOIS - URBANA  
UNIVERSITY OF WISCONSIN - MADISON  
KANSAS STATE UNIVERSITY  
UNIVERSITY OF UTAH  
UNIVERSITY OF COLORADO - DENVER  
FLORIDA A&M UNIVERSITY  
UNIVERSITY OF BUFFALO  
UNIVERSITY OF SOUTH CAROLINA  
TENNESSEE STATE UNIVERSITY  
AUBURN UNIVERSITY  
PRAIRIE VIEW A&M UNIVERSITY  
LAMAR UNIVERSITY  
UNIVERSITY OF TEXAS AT ARLINGTON

## **CENTERS FOR THE COMMERCIAL DEVELOPMENT OF SPACE CURRENT STATUS**

---

- **32 UNIVERSITY PARTICIPANTS**
- **119 INDUSTRIAL BUSINESS PARTICIPANTS**
- **IDENTIFIED 129 PRODUCTS/PRODUCT CATEGORIES**
- **615 DROP TUBE/TOWER EXPERIMENTS**
- **21 KC-135 FLIGHT EXPERIMENTS**
- **1 SERIES OF LEAR JET FLIGHTS**
- **4 STS FLIGHTS**
- **5 EXPERIMENTS PREPARED FOR FIRST SOUNDING ROCKET FLIGHT**
- **SMALL BUSINESS PARTICIPATION BEING DEVELOPED FOR SMALL BUSINESS INNOVATION RESEARCH AWARDS**

# CENTERS FOR COMMERCIAL DEVELOPMENT OF SPACE NATIONWIDE

280

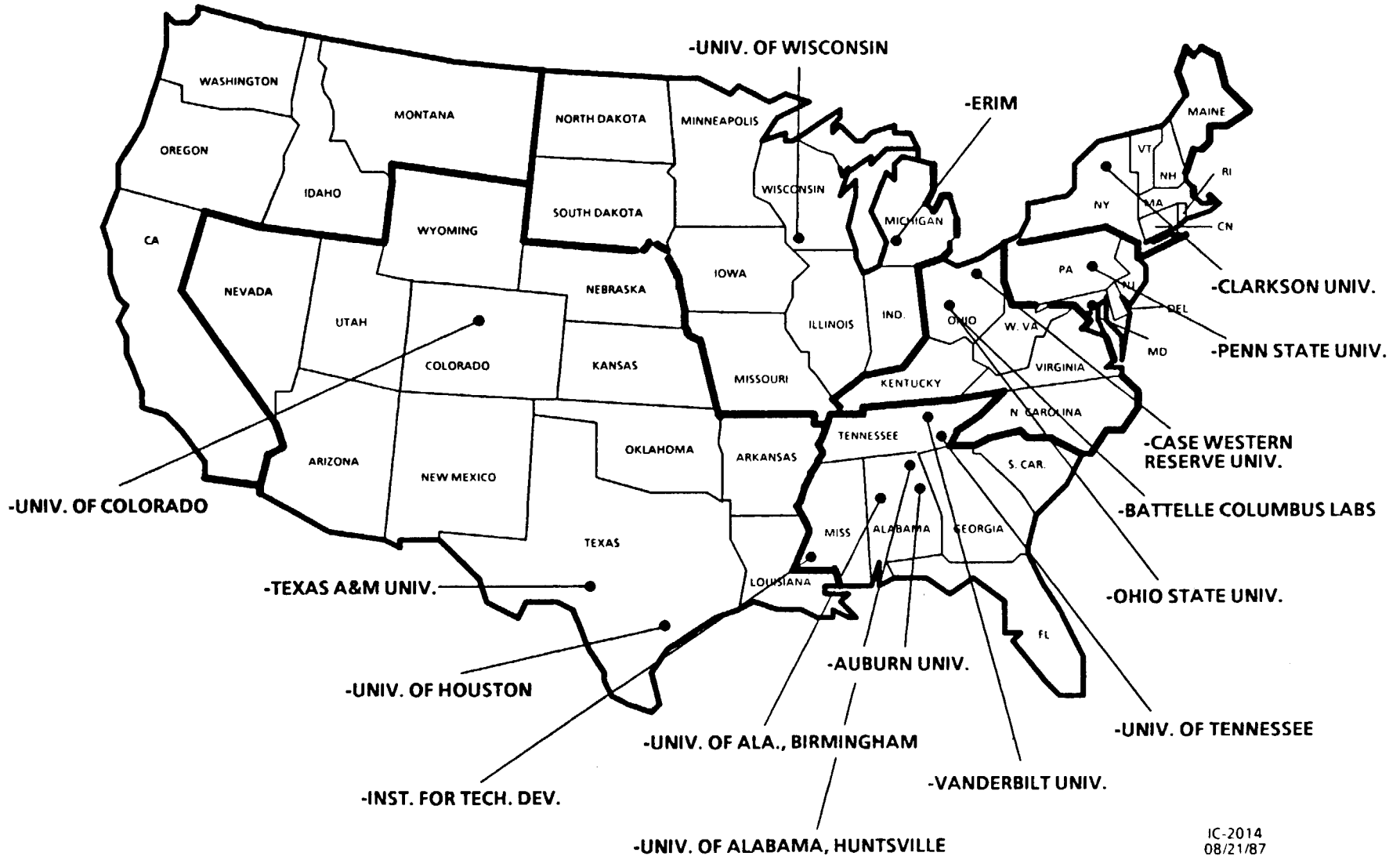

# CENTERS FOR THE COMMERCIAL DEVELOPMENT OF SPACE OBJECTIVES AND CRITERIA

---

## OBJECTIVE

- PROVIDE THE PATHWAY FOR U.S. INDUSTRY TO DEVELOP LEADERSHIP IN THE COMMERCIAL USE OF SPACE
  - DEVELOPING PROGRAMS THAT FOSTER NEW TECHNOLOGY DEVELOPMENT
  - DEVELOPING PROGRAMS THAT LEAD TO NEW COMMERCIAL PRODUCTS

281

## GENERAL CRITERIA

- NEW AND UNIQUE TECHNOLOGY DEVELOPMENT AND SYSTEMS LEADING TO COMMERCIAL USE OF THE SPACE ENVIRONMENT
- HIGHLY SPECIALIZED UNIVERSITY BASED CENTERS TO HELP U.S. INDUSTRY FOCUS ON TECHNOLOGY DEVELOPMENTS THAT ARE COMMERCIALY-ORIENTED
- SYSTEMATIC EVOLUTION OF CENTERS TO BECOME HIGHLY INDEPENDENT OF NASA THROUGH THEIR DEVELOPMENT OF INDUSTRIAL COMMITMENT

# OFFICE OF COMMERCIAL PROGRAMS

282

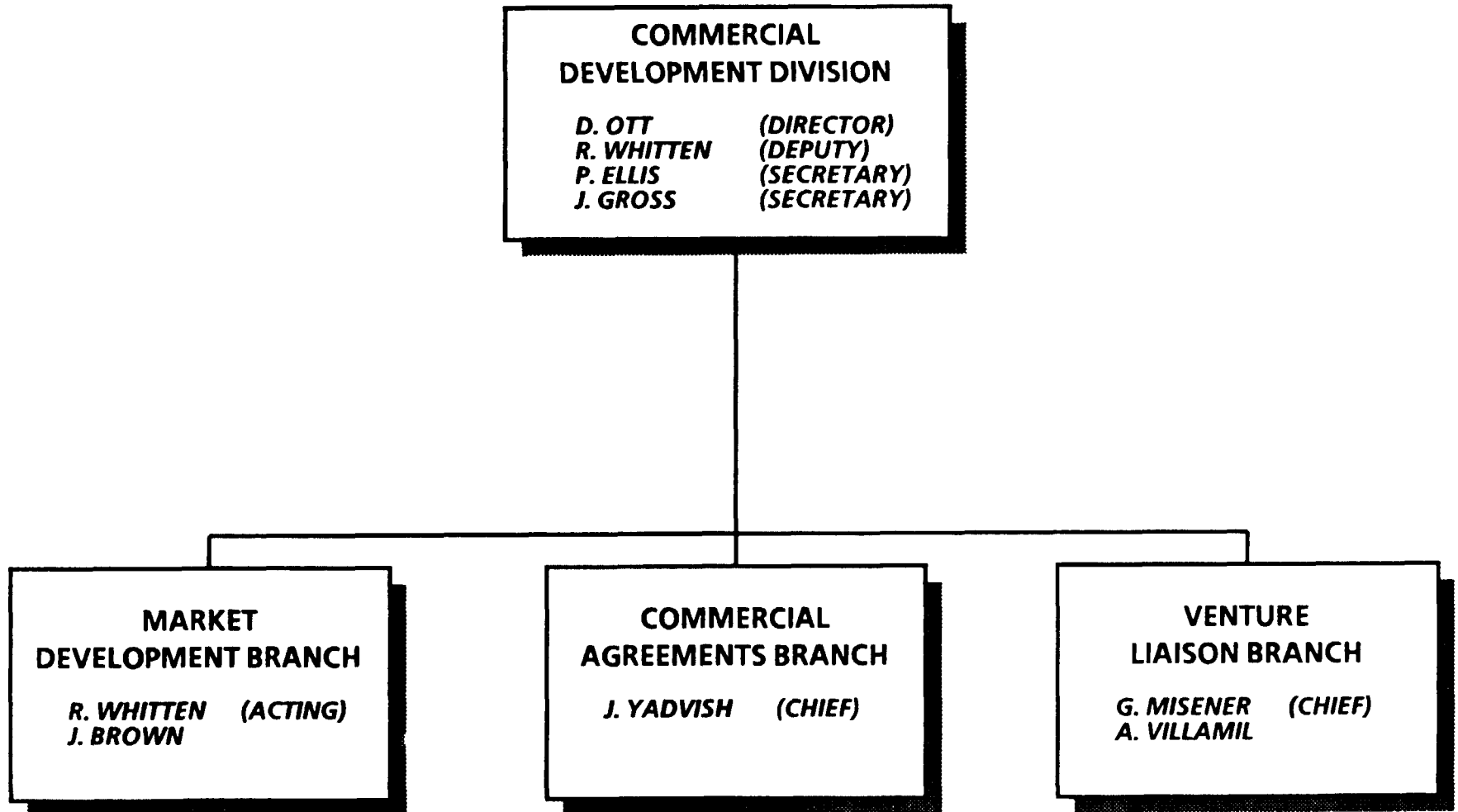

# OFFICE OF COMMERCIAL PROGRAMS ORGANIZATION

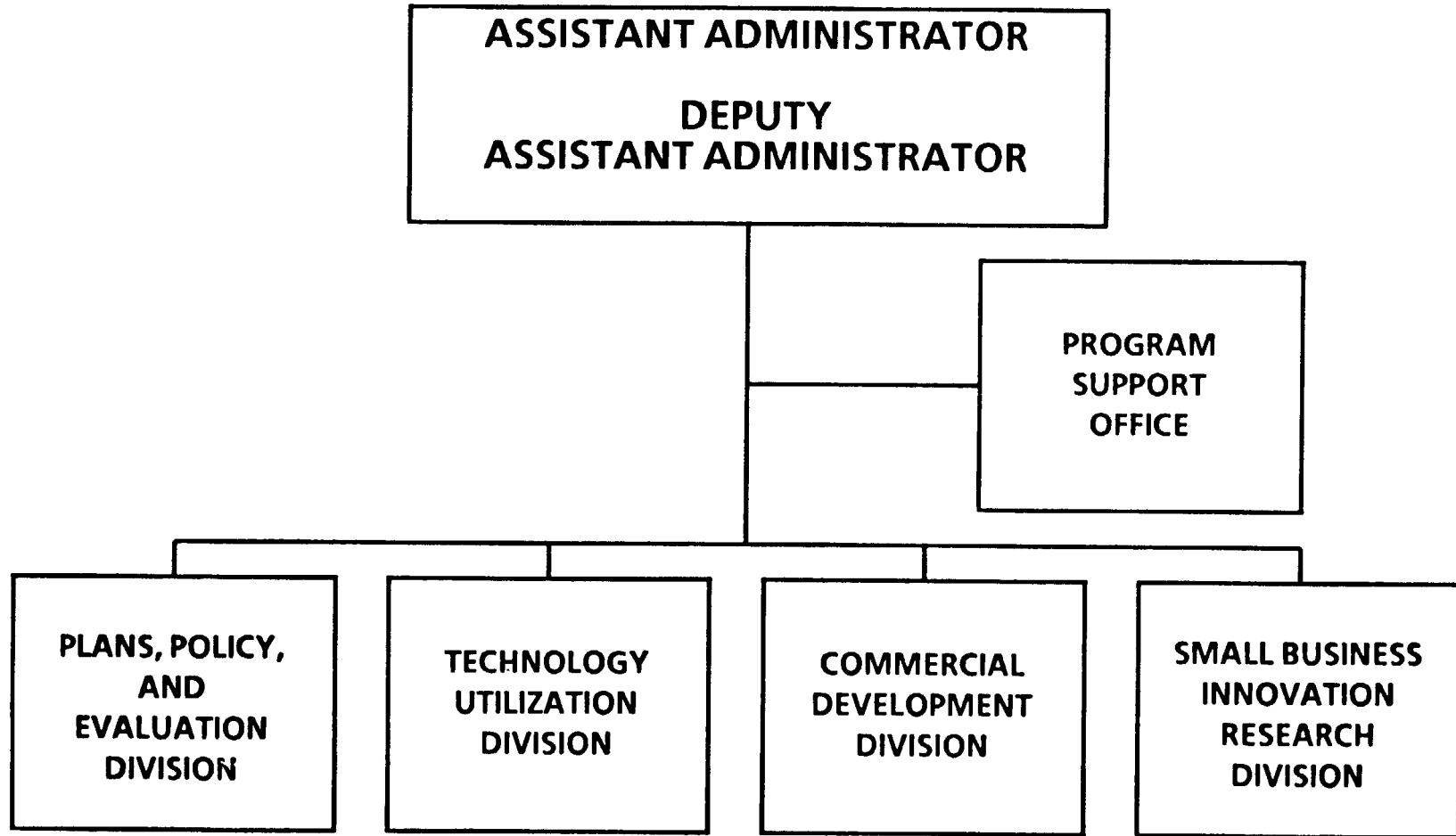

283



# EXECUTIVE AND LEGISLATIVE BRANCH PRONOUNCEMENTS IN SUPPORT OF COMMERCIAL SPACE

---

*"We will soon implement a number of executive initiatives, develop proposals to ease regulatory constraints, and with NASA's help, promote private sector investment in space."*

State of the Union Address, 1984

*"In the zero gravity of space, we could manufacture in 30 days life saving medicines it would take 30 years to make on Earth. We can make crystals of exceptional purity to produce super computers, creating jobs, technologies and medical breakthroughs beyond anything we ever dreamed possible."*

State of the Union Address, 1985

*"The Congress declares that the general welfare of the United States requires that the National Aeronautics and Space Administration seek and encourage to the maximum extent possible, the fullest commercial use of space."*

Public Law 98-361, 1984

**MAINTAINING AND ENHANCING  
U.S. LEADERSHIP IN  
COMMERCIAL SPACE ACTIVITIES**

## CONCLUSIONS/CLOSING REMARKS

Robert S. Bandurski and Paul Todd

This conference marks a watershed between the period when space was being tested for safety and the new period in which space is regarded as an important adjunct to our studies of biological, physical, and chemical phenomena. It was implicit in the numerous presentations and discussions that there will be increasingly frequent opportunities for experimentation in space, that generic hardware will facilitate the performance of space experiments, and that there will be commercial utility to space. Most importantly, there was a melding of physical and biological knowledge and an emphasis on how the weak forces of gravity are able to affect organisms composed of covalent and non-covalently bonded molecules.

It was correctly observed during the conference that it is the life forms that have developed, evolved, and grown on earth that constitute the 1-g experiment. The micro-g, and fractional-g controls attainable in space have, in general, rarely been done. We are now ready to study the micro-g controls and, for the first time, to understand the effects of 1-g.

This conference has convinced us that complex biological systems will greatly contribute to our knowledge of the physics of gravity.

## CONFERENCE DEDICATIONS

### Professor George Nace

(Provided by Kenneth Souza)

George Nace was born in 1920 in Cogsville, Pennsylvania. His parents were missionaries in Japan where, in his early childhood, he developed fluency in Japanese. During the second World War he was actively engaged for 2-3 years as an interpreter with the occupation forces where his fluency in Japanese was valuable. After his early years in Japan he came back to the United States, where he attended Reed College in Oregon and earned a degree in Biology. He then went to UCLA and obtained his masters and doctoral degrees in Zoology. Following a few years doing post-doctoral work, he joined the staff at the University of Michigan in 1957, where he remained until 1984 when he retired as Professor Emeritus. He died in 1987.

It was during his tenure at University of Michigan, that I first became acquainted with him and his involvement in the frog rearing and culturing activities. He was a great proponent of ecological studies of amphibia and an expert in their nurturing and rearing in the laboratory. By carefully controlling the environment in which the amphibia were reared, Professor Nace could guarantee the quality of specimens for the investigator. When Rana pipiens became difficult to obtain because of over-collection during the 1960's and 70's, he became a supplier in every sense of the word. He founded his own company and had facilities where he developed a feeding technique which enabled him to raise Rana pipiens through metamorphosis to the adult stage. A 1985 issue of *Science* magazine featured Professor Nace and described his forte: the culture and rearing of a wide variety of "designer" amphibia or genetically-marked strains.

In 1978 Professor Nace joined with John Tremor, Muriel Ross and me to develop the Frog Embryology Experiment now scheduled to fly on Spacelab J. While he remained a member of the Frog Embryology experiment his primary focus was on teaching, particularly in teaching students to convey the message that amphibia could be raised in the laboratory setting. Some of his students returned to Korea and Japan where, as a consequence, he came to be a recognized and respected expert in amphibian biology. Over the past two decades Professor Nace served on a variety of NASA advisory committees and working groups. He was one of the first space biologists to recognize the need to include physicists in the analysis of microgravity experiments. It was during collaboration with a few physicists at the University of Michigan that Professor Nace developed what he called the torsional model of gravitational effects on the cell. The subject and focus of this event is a tribute to some of the insights and ideas of Professor Nace. I am pleased to dedicate this conference to him.

PRECEDING PAGE BLANK NOT FILMED

## **Professor Per F. Scholander**

**(Provided by Robert S. Bandurski)**

The Cells in Space Conference deals with the most exciting voyage on which humans have yet embarked -- the voyage into space. Thus, it is singularly appropriate that this conference be dedicated to Professor Per F. (Pete) Scholander -- a pathfinder of the first order. He knew that opportunities to understand life processes lie at the fringes of our environment--where living creatures face extremes of cold and heat, of wet and dry, of salty and salt free. He realized that it was at these extremes that life would most vividly reveal its secrets. Of all scientists he would have shared our excitement at the prospects of this journey into space.

Scholander was Professor Emertius of Physiology and the first Director of Scripps's Physiological Research Laboratory. He was born in Orebo, Sweden on November 29, 1905, and moved to Norway at an early age. He received his Doctorate in Medicine from the University of Oslo, Norway, in 1932 and the Doctorum Honoris Causa from Uppsala in 1977. He was elected to the National Academy of Sciences and the American Philosophical Society. He died on June 13, 1980, in La Jolla, a suburb of San Diego, California, at the age of 74.

Scholander had many research accomplishments usually characterized by the use of extraordinarily simple equipment, often built by himself, and capable of use in the extreme environments of the field. These included the Wick Technique for measurement of fluid pressures in animals and the Pressure Bomb for measuring solute osmotic pressures in plants. He was fascinated by the problem of getting water to the top of tall trees and, in this connection, used a rifle to shoot down branches from 100-meter-tall trees so their osmotic pressures might be measured. He investigated blood circulation and respiratory problems in diving animals, particularly the physiological mechanisms which act to prevent oxygen deficiency in brain tissue. He studied bradycardia, the cutting off of peripheral circulation, which developed in mammals upon submersion in water, or in fish upon removal from water. He studied climatic adaptations in arctic and tropical animals and the dynamics of negative tissue-fluid pressures in animals. He advanced the idea that an anti-free substance is present in fish living in polar waters and was among the first to analyze the composition of gas bubbles in glacial ice to determine atmospheric conditions in ancient times.

Professor Scholander was responsible for obtaining funds from the National Science Foundation for building and operating the Alpha Helix--the world's first floating physiological biochemistry laboratory. The Alpha Helix, in addition to well-equipped laboratories, had an ice breaking prow and the stern of a Norwegian Whaler to carry scientists to the extremes of the world's climatic conditions.

How fitting that we should also dedicate this conference to Professor Scholander. We hope that memories of his vision will accompany us into the environs of space.

**ATTACHMENTS**

~~PREVIOUS PAGE IS NOT REPRODUCED~~

## ATTACHMENT A

### CELLS IN SPACE-II CONFERENCE PARTICIPANTS

Dr. Rodney Ballard  
NASA/Ames Research Center  
Mail Stop N240A-3  
Moffett Field, CA 94035  
(415) 694-6748

Dr. Robert Bandurski  
Department of Botany  
Michigan State University  
East Lansing, MI 48824  
(517) 355-4685/6589  
FAX (517)353-1926

Dr. Thomas Björkman  
Department of Botany  
KB-15 University of Washington  
Seattle, WA 98195  
(206) 543-3944

Dr. Allan Brown  
Gravitational Plant Physiology Lab  
3401 Market Street  
Suite 350  
Philadelphia, PA 19104  
(215)898-4908

Dr. Carlo Bruschi  
Biotechnology Laboratory  
East Carolina University  
School of Medicine  
Greenville, NC 27585-4354  
(919) 551-3131

Dr. Paul X. Callahan  
NASA/Ames Research Center  
Mail Stop N240A-3  
Moffett Field, CA 94035  
(415) 694-6046

David K. Chapman  
Gravitational Plant Physiology Lab  
3401 Market Street  
Suite 350  
Philadelphia, PA 19104  
(215)898-4908

Dr. Leonard Cipriano  
LESC  
Ames Research Center  
Mail Stop N240A-4  
P.O. Box 168  
Moffett Field, CA 94035  
(415) 694-6820

Dr. Donald Clifford  
McDonnell Douglas Astronautics  
P.O. Box 516  
Bldg. 101A, Level 3, Room 340E  
St. Louis, MO 63166  
(314) 232-2896

Dr. Augusto Cogoli  
Institute of Biotechnology  
ETH-Hönggerberg  
Ch 8093-Zurich  
411-372-3683  
FAX 411-372-0974

Dr. Gary W. Conrad  
Bioserve Research Program - Ackert Hall  
Kansas State University  
Manhattan, KS 66506  
(916)532-6662

PRECEDING PAGE BLANK NOT FILMED

Dr. Daniel Cosgrove  
Dept. of Biology, 202 Buckhout Lab.  
Pennsylvania State University  
University Park, PA 16802  
(814) 863-3892

Dr. Michael Cronin  
Genentech, Inc.  
460 Point San Bruno Blvd.  
South San Francisco, CA 94080  
(415)266-1920

Dr. Stanley B. Curtis  
Lawrence/Berkeley Laboratory  
M/S 29-100  
Berkeley, CA 94720  
(415) 486-6389

Bonnie Dalton  
NASA/Ames Research Center  
Mail Stop N240A-3  
Moffett Field, CA 94035  
(415) 694-6188

Dr. Daniel Deaver  
Asst. Professor, Animal  
Science/Physiology  
103 Dairy Breeding Research Center  
Pennsylvania State University  
University Park, PA 16802

Mark Deuser  
Space Hardware Optimization Technology  
P.O. Box 351  
Floyd Knobs, IN 47119  
(812) 923-9591

Dr. Jackie Duke  
Dental Science Institute/Un. Texas  
P.O. Box 20068, Dental Branch  
Houston, TX 77225  
(713) 792-4161

Dr. Eric Dunlop  
Dept. of Chemical Eng.  
Colorado State University  
Fort Collins, CO 80523  
(303) 491-6967

Dr. William Elmer  
Biology Department  
1555 Pierce Drive  
Emory University  
Atlanta, GA 30322  
(404) 727-4210

Dr. Tom Fast  
Santa Clara University  
NASA/Ames Research Center  
Mail Stop N240A-3  
Moffett Field, CA 94035  
(415) 694-6583

Dr. George W. Fortner  
Bioserve Research Program, Ackert Hall  
Kansas State University  
Manhattan, KS 66506  
(913)532-6624

Dr. John Frangos  
Department of Chemical Engineering  
Pennsylvania State University  
University Park, PA 16802  
(814) 863-4812

Dr. Wayne Gonzalez  
Lockheed Missiles and Space Co.  
6270 Gunter Way  
San Jose, CA 95123  
(408) 756-5686

Dr. Alan Greenberg  
Engineering Center  
Campus Box 427  
University of Colorado  
Boulder, CO 80309

Dr. Raphael Gruener  
University of Arizona  
College of Medicine  
Dept. of Physiology  
Tucson, AZ 85724  
(602)626-6519

Shirley Guilbert  
LESC  
Ames Research Center  
Mailstop N240A-4  
P.O. Box 168  
Moffett Field, CA 94035  
(415) 694-6579

Dr. Roy Hammerstedt  
Professor of Biochemistry  
406 Althouse Lab  
Pennsylvania State University  
University Park, PA 16802

Dr. A. Tyl Hewitt  
Wilmer Ophthalmological Institute  
John Hopkins University and Hosp.  
601 N. Broadway  
Baltimore, MD 21205  
(301) 955-7590

Dr. William Hinds  
LESC  
Ames Research Center  
Mailstop N240A-4  
P.O. Box 168  
Moffett Field, CA 94035  
(415) 694-6814

Robert Hogan  
NASA/Ames Research Center  
Mail Stop N240A-3  
Moffett Field, CA 94035  
(415)694-5248

Dr. Wesley Hymer  
Dept. Molecular and Cellular Biology  
Pennsylvania State University  
401 Althouse  
University Park, PA 16802  
(814) 865-9182

Dr. Gary Jahns  
NASA/Ames Research Center  
Mail Stop N240A-3  
Moffett Field, CA 94035  
(415) 694-6595

Dr. John Kessler  
Department of Physics  
University of Arizona  
Tucson, AZ 85721  
(602)621-2797/6820/6800  
(602)299-6522

Dr. Abraham Krikorian  
Biochemistry Department  
SUNY  
Stony Brook, NY 11794  
(516) 632-8568

Charles C. Kubokawa  
NASA/Ames Research Center  
Mail Stop N244-5  
Moffett Field, CA 94035  
(415) 694-5554

Ulrich Kuebler  
Bionetics  
Ames Research Center  
M/S 240-9  
Moffett Field, CA 94035

Joellen Lashbrook  
NASA/Ames Research Center  
Mail Stop N240A-3  
Moffett Field, CA 94035  
(415) 694-5682



Dr. Charles W. Lloyd  
Health Maintenance Facility  
Subsystem Management  
Krug International  
Houston, TX

Dr. Marvin Luttges  
Bioserve Research Program  
University of Colorado  
Campus Box 429  
Boulder, CO 80309  
(303) 492-7613 or 7713

Richard Mains  
Mains Associates  
2039 Shattuck Avenue  
Suite 402  
Berkeley, CA 94704  
(415)548-1261

Dr. Andrea M. Mastro  
Professor of Microbiology & Cell Biology  
431 S. Frear  
Penn State University  
University Park, PA 16802

Rich McKenna  
LESC  
Ames Research Center  
P.O. Box 168  
Moffett Field, CA 94035  
(415) 694-6797

Laurance Milov  
External Relations Office  
NASA/Ames Research Center  
Mail Stop N223-3  
Moffett Field, CA 94035

Helene Najduk  
External Relations Office  
NASA/Ames Research Center  
Mail Stop N223-3  
Moffett Field, CA 94035  
415-694-4034

Dr. Arthur J. Olson  
Research Institute of Scripps Clinic  
10666 N. Toy Pines Road  
LaJolla, CA 90237  
(619)554-9702

Dr. Delbert Philpott  
NASA  
Ames Research Center  
M/S 239-14  
Moffett Field, CA 94035

Yvonne Russell  
Russmark, Inc.  
602 Stendahl Lane  
Cupertino, CA 95014  
(408)252-8316

Dr. Ron Schaefer  
LESC  
Ames Research Center  
Mail Stop N240A-4  
Moffett Field, CA 94035  
(415)694-4438

Teri Schnepf  
Lockheed Missiles and Space Co.  
M/S 0-53-51  
Building 580  
Sunnyvale, CA 94088  
(408) 756-5940  
(408) 742-6139

Dr. P. K. Seshan  
Jet Propulsion Laboratory  
Mail Stop 125-112  
4800 Oak Grove Drive  
Pasadena, CA 91109  
(818) 354-7215

Dr. Jean D. Sibonga  
Mains Associates  
1076 College Avenue  
Palo Alto, CA 94306  
(415) 493-9441

Dr. Steven Smith  
Future Research  
4310 South Main St.  
Murray, UT 84107  
(801) 268-8832

Dr. Karam F. A. Soliman  
Dept. of Pharmacology  
Rm. 104, Dyson Building  
Florida A & M University  
Tallahassee, FL 32307  
(904)599-3306

Dr. Michael Solursh  
Department of Zoology  
University of Iowa  
Iowa City, IA 52242  
(319) 335-1058

Dr. Gerald Sonnenfeld  
Dept. of Microbiology & Immunology  
University of Louisville School of  
Medicine  
Health Sci Center  
Louisville, KY 40292  
(502) 588-6323

Kenneth Souza  
NASA/Ames Research Center  
Mail Stop N240A-3  
Moffett Field, CA 94035  
(415) 694-5736

Dr. Barry Taylor  
Loma Linda Medical School  
School of Medicine  
Department of Microbiology  
Loma Linda, CA 92350  
(714)824-4480

Dr. Paul Todd  
National Institute of Standards &  
Technology  
Center for Chemical Engineering 583.10  
325 Broadway  
Boulder, CO 80303  
(303)497-5563

Dr. John Tremor  
LESC  
Ames Research Center  
Mail Stop N240A-4  
P.O. Box 168  
Moffett Field, CA 94035  
(415)694-6820

Dr. Steve J. Upton  
Bioserve Research Program  
Kansas State University  
Manhattan, KS 66506

John Vellinger  
Space Hardware Optimization Technology  
922 Rochester Street  
Lafayette, IN 47905  
(317)474-4986

Dr. Howard Wachtel  
Engineering Center  
Campus Box 425  
University of Colorado  
Boulder, CO 80309

Dr. Lynn Wiley  
California Primate Research Center  
University of California  
Davis, CA 95616  
(916)752-8421

Dr. Charles Winget  
NASA/Ames Research Center  
Mail Stop N240A-3  
Moffett Field, CA 94035  
(415)694-5753

## **ATTACHMENT B**

### **CELL RESEARCH EXPERIMENTS (FLOWN/PLANNED)**

1. Plant/Animal Cell Cultures
2. Oocyte/Embryo Development
3. Microorganisms

The following tables provide a recent collection of space cell research experiments that have flown, or are planned. The experiments were obtained from a selected literature search and are divided into three groups: Plant/Animal Cell Cultures, Oocyte/Embryo Development, and Microorganisms.

Information provided in the tables includes: the name of the experiment, the mission on which it was flown/planned and the year, a brief description of the flight hardware, and a reference source (see Attachment D). In addition, the table for Plants/Animal Cell Cultures provides the organism used for the culture. The experiments are arranged in ascending order according to the date of the mission and each has been assigned a number for reference purposes.

Several experiments refer the reader to the Cell Research Flight Hardware descriptions in Attachment C (obtained from references in Attachment D).

**PRECEDING PAGE BLANK NOT FILMED**

1. Plant/Animal Cell Cultures

#	EXPERIMENT	ORGANISM	FLOWN/PLANNED	HARDWARE	REF.
A1	The Effects of Space Flight on Living Human cells - Chicken embryo tissue		Discoverer XVIII ('60)	Glass ampules, salt solution, 10% horse serum, refrig. units, neutron film pack, chem. dosimeters, gold foil, glass needle sets, 552 film strips, polyethylene foam (packing), alanine pcts, 1 step plate & film, nuclear track plates	(1) p. 121
A2	Exposure to Spaceflight	Hela Cultures	Sputnik 4 ('60)		(5) pp. 36-37
A3	Exposure to Spaceflight	Hela Cultures	Sputnik 6 ('61)		(5) pp. 36-37
A4	Exposure to Spaceflight	Hela Cultures	Sputnik 7 ('61)		(5) pp. 36-37
A5	Exposure to Spaceflight	Hela Cultures	Vostok1 ('61)		(5) pp. 36-37
A6	Exposure to Spaceflight	Hela culture	Vostok 2 ('61)		(5) pp. 36-37
A7	Exposure to Spaceflight	Hela culture	Voskhod-2 ('65)		(5) pp. 36-37
A8	Radiation and Zero-G Effects on Human Leukocytes and Neurospora crassa	Human, Microorganism	Gemini 3, 11('65, '66)	32P source, alum. blood-sample holder, dosimeter rods	(1) p. 155
A9	Radiobiological Studies of Tradescantia Plants Orbited	Plant Tradescantia	Biosat II ('67)	Expt pckgs of polypropylene plastic to hold 32 plants with nutrient solution thermistor, dosimeters	(1) p. 152
A10	Exposure to Spaceflight	Hela Cultures	Zond5 ('68)		(5) pp. 36-37
A11	Cell Growth in "Bioterm"	Cells from Syrian hamster (strain VNK-21)	Kosmos 368 ('70)	Bioterm apparatus temp. control	(5) pp. 36-37
A12	Effects of ZeroG on living cells	Human embryonic lung cells (WI-38)	Skylab 3 ('73)	Woodlawn Wanderer 9. See Hardware Section 1.	(2) p. 221
A13	Cytoplasmic Streaming	Water weed (Elodea)	Skylab 3, 4 ('73)	Vials, microcpe slides, cover slips, tweezers, microscope, microscope camera adapter, 16mm motion picture camera	(1) p. 149

298

1. Plant/Animal Cell Cultures (Continued)

#	EXPERIMENT	ORGANISM	FLOWN/PLANNED	HARDWARE	REF.
A14	Electrophoresis Experiment MA014	rat bone marrow, spleen, lymph node cells with addition of human erythrocytes as mar- kers and a mixture of human and rabbit erythrocytes	Apollo-Soyuz Test Project ('75)	Separation chamber consisting of 2 cooling plates. Electrodes	(1) p. 111
A15	Electrophoresis Tech. MA011	Human, rabbit, & horse erythrocytes	Apollo-Soyuz Test Project ('75)	electrophoresis unit, a a cryogenic freezer, 8 expt columns, 8 sample insertion slides	(1) p.97
A16	Carrot Tumor Growth Expt.	Crown gall tumors developed on carrot disks	Kosmos 782 ('75)	Specially machined acrylic canisters, consisting of a stack of 3 closely fitted dishes. 2 machined anodized aluminum caps; filter pads with 12 air holes (pics in Final rept)	(6) p. 33
A17	Carrot Tissue Culture	Cultured carrot toti- potent cells	Kosmos 782 ('75)	Specially constructed canisters, plastic petri dishes; 2 anodized alum- inum alloy end -caps 12 air holes; 4 standoffs (picture in Final report)	(6) p. 71
A18	Cytological Studies of Mammalian Cell Cultures	Chinese hamster & mouse cells	Cosmos 1129 ('79)		(7) p. 9
A19	Studies of Carrot Crown Gall Tumor Growth		Cosmos 1129 ('79)		(8) p. 57
A20	Studies of Carrot Tissue Culture Morphogenesis		Cosmos 1129 ('79)	Basal medium of salts, sucrose, vitamins NAA	(8) p. 57 Pics of hardware, p 80
A21	Efficiency of Separation of cells in weightlessness	Rat pituitary cells	STS-8 ('83)		(3) p. 145
A22	Effects of low gravity on Mammalian Cell Polarization at the Ultrastruct. level	mammal plasma cells	Spacelab D-1 ('85)	Blood kit, Cell Culture Flasks, Syringes, Medium, Type 1 experiment containers. See Hardware Section 2.1, 2.2, 2.3, 2.4, & 3.	(4) p. 105

1. Plant/Animal Cell Cultures (Concluded)

#	EXPERIMENT	ORGANISM	FLOWN/PLANNED	HARDWARE	REF.
A23	Separation of Animal Cells and Cellular Organella by Means of Freeflow Electrophoresis	Cultured mammalian cells and their hybrid derivatives	Spacelab J ('91)	Free Flow Electrophoresis unit (FFEU) See Hardware section 13	(14) p. 26
A24	Rearrangement of Intermediate Filaments in Mammalian Cells in Culture	Several types of mammalian cells and tissues	Spacelab J ('91)	Thermoelectric Incubator (TEI) See Hardware section 14	(14) p. 30

2. Oocyte/Embryo Development

#	EXPERIMENT	FLOWN/PLANNED	HARDWARE	REFERENCES
	Embryogenesis - Ascaris eggs	Sputnik 6 ('61)		(5) p. 31
B2	Sea Urchin Egg Fertilization and Development	Gemini 3 ('65)	Cylinder of 8 specimen chambers, each divided into 3 compartments separating sperm, ova and fixative solution	(1) p. 139
B3	Embryology development studies - 20 Rana eggs	Gemini 8 ('66) Gemini 12 ('66)	4 specially developed acrylic chambers, temp held at 4 C then raised to 21 C at orbit. Eggs then injected with glutaraldehyde fixative at various stages.	(9) p. 193 (10) p. 62
B4	Effect of Weightlessness on the Dividing Eggs - (B. frog) - 120 Rana eggs	Biosat. I ('66) Biosat. II ('67)	16 acrylic modules divided into 2 chambers, a 10 ml egg chamber, and a 4 ml-fixative chamber, a coolant line around the pkg to maintain it at 42.5 oF, thermistors	(1) p. 137
B5	Amphib. development - differentiation and function of the gravity sensing system in early embryos exposed to microgravity.	Soyuz-9 ('70) Soyuz 17 ('75) Soyuz 26 ('77) Soyuz 36 ('80) Soyuz 39 ('81) Soyuz 40 ('81)	Placed eggs from Rana temporaria and Xenopus laevis in containers. At various stages of development, glutaraldehyde was injected manually.	(5) p. 27 (10) p. 62
B6	BIOSTACK I, II To study biological effects of individual heavy nuclei with high energy loss (HZE) - Brine Shrimp eggs	Apollo 16, 17 ('72)	Hermetically sealed aluminum container, containing series of select biologic mat'l each sandwiched b/t several types of dosimeters and thermistors	(1) p. 128
B7	BIOSTACK II - Grasshopper eggs	Apollo 17 ('72)		(1) p. 129
B8	BIOSTACK II - Flour beetle eggs	Apollo 17 ('72)		(1) p. 130
B9	Development of Fundulus heteroclitus - 50 fert. eggs	Skylab 3 ('73)	No special equipment (not intended to be an experiment)	(9) p. 193

2. Oocyte/Embryo Development (Continued)

#	EXPERIMENT	FLOWN/PLANNED	HARDWARE	REFERENCES
B 10	Fundulus dev. - 500 embryos	Apollo-Soyuz ('75)		(9) p. 194
B 11	5 development stages of Fundulus studies (500 embryos)	Kosmos 782 ('75)	Machined aluminum, 2 chamber, cuboid case with 5 polyethylene bags (Picture in Final rept)	(6) p. 179
B 12	BIOSTACK III To study the influence of HZE particles on development, morphogenesis, and histology - Brine S., flour b. & grass-H. eggs	Apollo-Soyuz Test Project ('75)	PVA, 2 cylindrical aluminum containers, K2 nuclear emulsion plates	(1) p. 131
B 13	Killifish Hatching and Orientation	Apollo-Soyuz Test Project ('75)	Transport control pkg, experimental pkg, rotating striped drum, photog. equipment	(1) p. 132
B 14	Study of Embryogenesis in Jap. Quail - 60 Coturnix eggs	Cosmos 1129 ('79)	Inclubator	(9) p. 196; (7) p. 324
B 15	Embryogenesis & Organogenesis in spaceflight - Stick insect Carausius	Spacelab D-1 ('85)		(4) p. 107
B 16	Fertilization & Development in Spaceflight - M&F gametes African Clawed frog	Spacelab D-1 ('85)	Special containers with 6 compartments were fabricated for individual storage of eggs, sperm glutaraldehyde fixative, Ringers solution, distilled water, and an anti-sperm sera to label the spot of sperm penetration. Temp. maintained in chambers at 11 C until orbit. 1 to 2 hours after reaching orbit, chambers placed in incubator at 22 C. A microprocessor on each container then activated plungers in each chamber mixing sperm and eggs and subsequently flooded them with dilute Ringers solution. Fixation of all specimens occurred about 8 to 9 hours after fertilization (at gastrula stage).	(10) p. 64

302



2. Oocyte/Embryo Development (Concluded)

#	EXPERIMENT	FLOWN/PLANNED	HARDWARE	REFERENCES
B17	Embryonic Development of the Vertebrate Gravity Receptors - Clawed frog eggs	Spacelab D-1 ('85)	Fertilized eggs stored at 10 C in incubator located in a Space Shuttle middeck locker. 7 hours after launch, the developmental rate was accelerated by raising temp. to 20 C with in incubator in spacelab.	(10) p. 63
	<b>FUTURE EXPERIMENT:</b>			
B18	Fertilization and development in Microgravity	Spacelab-J ('91)	Designed to fly 4 adult females . Spacelab crew to induce ovulation and subsequent fertilization during the flight. Damp foam-lined box through which 100 cc/min of air will be circulated. Sperm suspension will also be prepared. Adult Frog Container (AFC) loaded into a special incubator, The Frog Environmental Unit (see fig. ) located in the spacelab. AFC will be transferred to the General Purpose Work Station ( a glovebox containing chemical and biological materials - see fig.). In the GPWS, the frogs will be injected with chorionic gonadotropin to induce ovulation. Chambers filled with dilute Ringers solutions will hold eggs covered with sperm suspension. Incubation temp. will be 21 C. See Souza article for details.	(10) p. 65 pics on pp. 66,67

303

### 3. Microorganisms

#	EXPERIMENT	FLOWN/PLANNED	HARDWARE	REFERENCES
C1	<b>Radiobiology Expts .</b> II Clostridia Spore labilization: A Biological System to quantitate radiation	Discoverer XVII, XVIII ('60)	Caramelized glucose, glass ampules refrig. units for the ground, thermistors track plates, chem. dosimeters, needle sets	(1) p. 157
C2	Correlate traversal of primary cosmic rays with an increase in mutation in a population of cells lying along the track path - Neurospora crassa	Discoverer XVIII ('60)	Biological track plate, millipore filters, photog. emulsion on a 2"x2" sheet of glass, neutron sensitive film, Ansco 552 film, antimony foil, alanine and albumin	(1) p. 159
C3	Experiments with Photo- Synthetic Organisms - Algae	Discoverer XVII ('60)	Glass vials, chem. dosimeters, modi- fied Kratz's medium (D-17), Evelyn photoelectric colorimeter, alanine, albumin, silver-activated phosphate glass rods, Ansco 522 Film, neutron sensitive film, antimony foil, nuclear track plates	(1) p. 166
C4	Genetic Experiments on NERV - Neurospora crassa	NERV 1 ('61)	Experiment capsules	(1) p. 158
C5	Survival - Actinomycetes	Sputnik 6 ('61)		(5) p. 35
C6	Survival - Actinomycetes	Sputnik 7 ('61)		(5) p. 35
C7	Survival - Yeast	Vostok 2 ('61)		(5) p. 31
C8	Survival - Yeast	Voskhod 1 ('64)		(5) p. 31
C9	Mutational and Physiologi Responses of Habrobracon - Parasitic wasp, brine shrimp cysts, Saccharomyces cerevisiae	Biosat II ('67)	Habrobracon flight containers, 85Sr source, LIF powder, glass rod dosimeters	(1) p. 135
C10	Mutagenic effectiveness of Known Doses of Radiation in Combination with Zero-G on Neurospora crassa	Biosat II ('67)	Millipore filters, LIF disk dosimeter, porous retaining rings, module of sample holders, 85Sr source, thermistor	(1) p. 160

304

3. Microorganisms (Continued)

#	EXPERIMENT	FLOWN/PLANNED	HARDWARE	REFERENCES
C11	Effects of Weightlessness on the Nutrition and Growth of <i>Pelomyxa carolinensis</i> Amoeba	Biosat II ('67)	Expt pckg with 24 chambers each divided into 3 5-ml compartments containing either amoeba, paramecium or fixitive. The chambers were mounted on magnesium plates. 4 of the chambers contained thermistors.	(1) p. 95
C12	Nuclear and Cellular Division in <i>Pelomyxa carolinensis</i> during Weightlessness (Amoeba)	Biosat II ('67)	same as (7)	(1) p. 103
C13	Radiation Exposures During Flight - Variety Animal & Plant microorganisms	Biosat II ('67)	Capsule, experiment pckgs, nuclear emulsion pckg, back-scatter shield, heat shield, source holder, 85Sr source, LiF powder dosimeters, CaF2 dosimeters	(1) p. 119
C14	Survival - Yeast	Kosmos 368 ('70)		(5) p. 31
C15	BIOSTACK II To study biological effects of individual heavy nuclei with high energy loss (HZE) - Protozoan cysts	Apollo 17 ('72)	Hermetically sealed aluminum container	(1) p. 167
C16	Microbial Response to Space Environment - Various	Apollo 16 ('72)	See (72)	(1) p. 172
C17	Symbiotic Growth of <i>Chlorella</i> and Kefir in Micro-Gravity (Algae & Yeast)	STS 51-G ('85)		(4) p. 96

305

3. Microorganisms (Concluded)

#	EXPERIMENT	FLOWN/PLANNED	HARDWARE	REFERENCES
18	Contraction Behaviour and Prototyping Streaming in the Slime Mould Physarum Polycephalum	Spacelab D-1 ('85)	Designed light microscope that could be mounted in the Biorack glovebox. The microscope contained 16-mm film cassetts to register the shuttle streaming and permitted the integration of the photo-diode in one ocular for registration of the radial contractions of a strand. The analogue signals of the diode were digitized by means of digitizing amplifiers. The amplifier electronics were especially developed for this Spacelab experiment.	(12) p. 55
C19	The Paramecium Experiment	Spacelab D-1 ('85)	Cells cultivated in a straw medium bacterised with Aerobacter aerogenes. 10 day, postautogamous cells were isolated by cloning. The eight sister cells obtained after 3 divisions were isolated and each cell placed in a small plastic bag with 0.65 ml of culture medium. Each bag included 2 small glass ampullae filled with 30 µl of a fixative (glutaraldehyde 35% in cacodylate buffer 0.2 M) according to the techniques developed for the Cytos experiments. After welding the bags and checking cell viability, the bags were placed in culture boxes. Each box included 4 small metallic spindles, which, when rotated by a crew member, caused the glass ampullae to break. Fixative then spread out so that the whole culture was fixed within 1 or 2 minutes. Culture boxes	(12) p. 70

306

**ATTACHMENT C**

**CELL RESEARCH HARDWARE/FACILITIES  
(FLOWN/PLANNED/EXISTING)**

1. Cell Research Flight Hardware
2. Groundbased NASA Facilities

1. Cell Research Flight Hardware

	A	B	C	D	E
1	#	HARDWARE	DESCRIPTION	MISSIONS	REFERENCE
2					
3	1	Woodlawn Wanderer 9	Maintained ambient temp. of b/t 10 C and 35 C.	Skylab	(2) p. 222
4			Sealed to provide 1atm pressure. Internally, the		
5			package is separated into a camera-microscope		
6			section and a separately sealed growth curve		
7			experiment section. See Fig.		
8					
9	2.1	Blood-Kit	Consisted of a bag of Nomex containing lithium-	Biorack on	(12) p. 90
10			heparin coated syringes, tourniquets, cotton-wool	Spacelab D-1	
11			balls, surgical tape, wiping towels.		
12					
13	2.2	Cell Culture flasks	Made of teflon/glass fiber consisted of cylindrical	Biorack on	(12) p. 90
14			chambers (10 ml) sealed by a mobile piston, and	Spacelab D-1	
15			were designed and developed in our laboratory. 2		
16			such flasks fit into Type I standard Biorack expt		
17			container. Fresh blood samples and other reagents		
18			were injected (using 1ml tuberculin syringes) into		
19			the flasks through a silicon rubber septum fitted in		
20			the piston.		
21					
22	2.3	Syringes	Used for injecting con A, 3H-thymidine, and glutar-	Biorack on	(12) p. 90
23			aldehyde, modified so that 8 would fit into a Biorack	Spacelab D-1	
24			container.		
25					
26	2.4	Medium	The medium (RPMI 1640, Gibco) was supplemented	Biorack on	(12) p. 91
27			with 20% heat-inactivated human serum of the same	Spacelab D-1	
28			blood group as the donor's, and contained 1000 I.U.		
29			heparin, 50 mg/ml gentamycin, 40mM Hepesbuffer		
30			and 5 mM sodium bicarbonate. The last 2 components		
31			permit culture growth in the absence of a controlled		
32			CO2 atmosphere in sealed flasks. Cells were stimu-		
33			lated by injecting con A at 50 mg/ml.		

308

1. Cell Research Flight Hardware (Continued)

	A	B	C	D	E
3 4	#	HARDWARE	DESCRIPTION	MISSIONS	REFERENCE
3 5					
3 6	3	3 Type I experiment	A flight container (FM), a ground control container	Biorack on	(12) p. 102
3 7		containers	(TM) and a spare one. Each contained 4 sets of 2	Spacelab D-1	
3 8			bags each with 1.4 ml of cell suspension (200,000		
3 9			cells/ml) and either no ampoules, 2 ampoules with		
4 0			fixative or 4 ampoules 2 containing fixative, and 2		
4 1			with labelled Uridin on a plastic support. The plastic		
4 2			bags were sealed before being placed in the experi-		
4 3			ment containers. In flight, crew members broke the		
4 4			glass ampoules at scheduled times to release the fix-		
4 5			ative or labelled solution.		
4 6					
4 7	4	Fluid Experiments	Designed to provide industrial users with a conven-		
4 8		Apparatus (FEA)	ient, low-cost, modular experiment system for fund-		(13) p. 4-11
4 9			amental space-processing research in biology,		
5 0			chemistry, and physics. With the FEA, investigators		
5 1			can conduct basic and applied processing or product		
5 2			development experiments in general liquid chemistry,		
5 3			crystal growth, fluid mechanics, thermodynamics,		
5 4			and cell culturing of biological materials and living		
5 5			organisms. This general-use, adaptable facility can		
5 6			be configured to manipulate a wide variety of exper-		
5 7			iments including gaseous, liquid, or solid samples,		
5 8			expose samples to vacuum conditions, and heat and		
5 9			cool samples. A number of specialized subsystems		
6 0			are planned for the FEA, including low-high-temper-		
6 1			ature furnaces, custom-designed heaters, special		
6 2			sample containers and a specimen centrifuge. These		
6 3			modules will allow FEA hardware and operations to be		
6 4			customized to support a wide range of experiment		
6 5			requirements.		

309

1. Cell Research Flight Hardware (Continued)

	A	B	C	D	E
66	#	HARDWARE	DESCRIPTION	MISSIONS	REFERENCE
67					
68	5	Refrigerator freezer	An active unit with a temperature range from -22 to		
69			+ 10 C. It can be used to cool blood, body fluids, and		
70			cell samples as well as solutions and fluids intended		
71			for injection. It also may be used to house small ani-		
72			mals, to incubate amphibian zygotes and to stow animal		
73			food supplies. It is designed to accept experiment		
74			racks, shelves and containers for a variety of pur-		
75			poses. 2 units are available: 1 designed for the orbiter		
76			middeck and 1 for Spacelab.		
77					
78	6	Phase partitioning expe-	Measures the spontaneous demixing of liquid-liquid,		
79		riment apparatus (PPE)	aqueous polymer 2-phase systems. 2 phase separa-		(13) p. 4-35
80			tion is universally used to separate biological cells and		
81			proteins. PPE permits the study of altering volume		
82			ratios, viscosity, interfacial tension, interfacial bulk		
83			phase potential, phase composition on the kinetics of		
84			demixing and the effects of chamber geometry, mate-		
85			rials and wall coatings of the foregoing parameters.		
86			The PPE is configured to study natural coalescence and		
87			surface tension, 2 methods of phase separation. It also		
88			allows variations in interfacial tension, phase volume		
89			ratio, phase system composition and added particles.		
90			Up to 24 separate cavities can be filled with small		
91			quantities of 2 different polymers in simple water/		
92			salt solutions. The apparatus is shaken and photo-		
93			graphed to record phase separation.		
94					
95	7	Refrigerator/incubator	An active unit with a temperature range from 0 to		
96		module	+40 C. The temperature is set using a front-mounted		(13) p. 4-37
97			variable potentiometer. Switching between the re-		
98			frigeration and incubation modes occurs automatically		



1. Cell Research Flight Hardware (Continued)

	A	B	C	D	E
99	#	HARDWARE	DESCRIPTION	MISSIONS	REFERENCE
100					
101	8	Refrigerator/incubator	Provides an easily integrated, temperature-controlled		
102		module (R/IM)	storage area for experiment samples, such as living		(13) p. 4-36
103			cells, organisms and materials which must be main-		
104			tained at specific temperatures in preparation for or		
105			after processing. This R/IM can be controlled to 1		
106			degree intervals between 4 and 37.5 C.		
107					
108	9	Tissue Culture incubator	Capable of maintaining 37 C (+/- 0.5 C). It can house		
109			4 15-ml cultures. The culture chambers are made of		(13) p. 4-41
110			teflon and glass and are equipped with a septum per-		
111			mitting the addition of material in flight via syringes		
112			also stored in the incubator. The syringes may be		
113			either modified 5-ml or standard syringes. The cul-		
114			tures are designed to be liquid only. Volume expansion		
115			of the culture vessels is achieved by a teflon-sleeved		
116			piston arrangement in which the septum is housed.		
117			The incubator can be mounted in a standard 19-inch		
118			electronics (or experiment) rack or be carried alone		
119			in a battery mode removed from the rack.		
120					
121					
122	10	Cell Culture Kit	A set of apparatuses, main chamber units, medium	Planned for	(14) p. 26
123			containers, waste collectors, and glutalaldehyde	SL-J mission	
124			applicators, for mammalian cell culture experi-	--Japanese	
125			ments. The main chamber unit has 2 rooms sepa-		
126			rated by a semipermeable membrane with 2 sets of		
127			septa for medium exchanges or chemical treatments		
128			free from contamination. The oxygen concentration		
129			in the medium can be spontaneously maintained		
130			from the atmosphere. The temperature and humi-		
131			dity are controlled by the incubator (TEIHT).		
132			Plant culture chambers are also included in kit.		
133			See fig.		
134					
135	11	Type I container	With the microchambers fitted with agar-coated red	Spacelab D-1	(12) p. 59
136			glass windows and a microscope. (for Slime mold		
137			Physarum Polycephalum experiment)		
138					
139	12	Culture box	(see description with pictures)	Spacelab D-1	(12) p. 70-71

1. Cell Research Flight Hardware (Concluded)

	A	B	C	D	E
140	#	HARDWARE	DESCRIPTION	MISSIONS	REFERENCE
141					
142	13	Free Flow Electrophoresis Unit (FFEU)	A continuous flow type electrophoresis equipment developed for the charged material separations under conditions of microgravity. The separation chamber has been modified to be much thicker compared to ground use equipment, because there are no restrictions of thermal convection or sedimentation phenomena.	Spacelab J-1	(14) p. 26 (pics)
143					
144					
145					
146					
147					
148					
149					
150					
151					
152					
153					
154					
155					
156					
157	14	Thermoelectric Incubator (TEI)	Developed for Spacelab experiments as a fundamental tool for life sciences. Both temperature and humidity are regulated at preset values.	Spacelab J-1	(14) p. 30(pics)
158					
159					
160					
161					
162					
163					
164					

312

2. Goundbased NASA Facilities

GROUND BASED FACILITIES				
NAME	DESCRIPTION	YEAR	REFERENCE	
Bioprocessing/Cell Biology Research Laboratory (CBRL)	Used for the culturing of cells for separation in ground-based and Space Shuttle flight experiments, evaluation of enzymes produced by separated cell subpopulations evaluation of attachment of cells to substrata in micro-gravity, development of experiments to evaluate the effects of space environment on cells, development of a bioreactor capable of operating in a microgravity environment, and preparation of cells for bioreactor studies. SUPPORTS: Cell biology and tissue culture research, cell production, and evaluation in support of Space Shuttle and Space Station experiments, design and construction of a space prototype bioreactor.	1979	(15) p.6.2-5	
Cytometry Lab.	Digitizes cell images for the analysis of biomedically important changes such as gross cell damage, chromosome breaks, or changes in cell age and type. Flourescent tagged cells may be identified, sorted, and recultured for further analysis as required (for example, in cell cycle analyses and the study of anomalies in the immune mechanism or in red blood cell production). SUPPORTS: Electro-optical digitization of cell images and fluorescent-activated flow cytometry.	1973	(15) p. 6.2-9	

313

**ATTACHMENT D**

**REFERENCES**

**PRECEDING PAGE BLANK NOT FILMED**

## LIST OF REFERENCES FOR ATTACHMENT B

### References for Cell Research Experiments (Flown/Planned)

1. Anderson, M., BIOSPEX: Biological Space Experiments: A Compendium of Life Sciences Bibliography, JSC-17072, NASA Johnson Space Center, prepared by Management and Technical Services Co., March 1981.
2. Montgomery, P., et al, "The Response of Single Human Cells to Zero-Gravity", in Johnston, R.S., & Dietlein, L.F., eds., Biomedical Results from Skylab, NASA SP-377, NASA Johnson Space Center, prepared by Scientific and Technical Information Office, 1977.
3. Martello, N.V., Biomedical Research Division Significant Accomplishments for FY 1983, NASA TM 85929, NASA Ames Research Center, Moffett Field, CA, prepared for Biomedical Research Division, 1984.
4. Halstead, T. and Dufour, P. eds., Biological and Medical Experiments on the Space Shuttle, 1981-1985, Life Sciences Division, Office of Space Science and Applications, NASA Headquarters, Washington, DC, 1986.
5. Ilyin, YE. A., Fundamental Results and the Prospects for Soviet Biological Experiments in Space, NASA TT F-14,822. Translation of: "Osnovnyye Itogi i Perspektivy Sovetskikh Biologicheskikh Eksperimentov v Kosmose," Moscow, Academy of Sciences of the USSR, Manuscript, 1973.
6. Rosenzweig, S., and K. Souza, editors, Final Reports of U.S. Experiments Flown on the Soviet Satellite Cosmos 782, NASA TM 78525. Ames Research Center, Moffett Field, 1978.
7. Heinrich, M. and Souza, K., editors, Final Reports of U.S. Rat Experiments Flown on the Soviet Satellite Cosmos 1129. NASA TM 81289. Ames Research Center Moffett Field, 1981.
8. Heinrich, M. and Souza, K., editors, Final Reports of U.S. Plant and Radiation Dosimetry Experiments Flown on the Soviet Satellite Cosmos 1129, NASA TM 81288. Ames Research Center, Moffett Field, 1981.
9. Mains, R. and Gomersall, E., editors, Final Reports of U.S. Monkey and Rat Experiments Flown on the Soviet Satellite Cosmos 1514, NASA TM 88223. Ames Research Center, Moffett Field, 1986.
10. Watanabe, S., et al, editors, Biological Sciences in Space 1986, Proceedings of the 1986 International Symposium on Biological Sciences in Space. MYU Research, Tokyo, Japan, 1987.

#### References for Cell Culture/Embryology Flight Hardware

11. Johnston, R. and L. Dietlein, editors, Biomedical Results From Skylab, NASA SP-377. Scientific and Technical Information Office, NASA Lyndon B. Johnson Space Center, Washington, D.C., 1977
  12. Longdon, N. and V. David, editors, Biorack on Spacelab D1, ESA SP-1091, ESA Publications Division, European Space Agency, Paris, France, 1988.
  13. Accessing Space: A Catalogue of Process, Equipment and Resources for Commercial Users, NASA NP-118, Office of Commercial Programs, NASA Headquarters, Washington, D.C., 1988.
  14. First Material Processing Test: Engineering Information Manual, Space Experiment Group, National Space Development Agency of Japan, Tokyo, Japan, 1986.
  15. Nace, G. "Gravity and the Positional Homeostasis of the Cell", in: *Advances in Space Research* 3(9):159-168, 1983.
- 

#### Reference for Ground-Based NASA Cell Culture Facilities

16. An Overview of the NASA Space Life Sciences Program, Life Sciences Division, NASA, Washington, DC, 1987.

### SUGGESTED READINGS

1. Cipriano, L.F., *A Capsule Summary: The Life Science Experience in Space 1948-1975*, Technology Incorporated, 1979.
2. Pollard, E.C., "Theoretical Studies on Living Systems in the Absence of Mechanical Stress", in *Journal of Biology*, Vol. 8, 1965, pp. 113-123.
3. Souza, K.A., and Halstead, T.W., *NASA Developmental Biology Workshop* Arlington, Virginia, May 1984, NASA TM 86756, Life Sciences Division, NASA Ames Research Center, Moffett Field, CA, 1984.
4. Tairebekov, M.G., et al, "Experimental and theoretical Analysis of the Influence of Gravity at the Cellular Level: A Review", in *Advances in Space Research*, 3(9), 1983, pp. 153-158.
5. Taylor, G.R., "Cell Biology Experiments Conducted in Space", in *Bioscience*, Vol. 27, 1977, pp. 102-108.



## Report Documentation Page

1. Report No. NASA CP-10034		2. Government Accession No.		3. Recipient's Catalog No.	
4. Title and Subtitle Cells in Space			5. Report Date August 1989		
			6. Performing Organization Code		
7. Author(s) Jean D. Sibonga and Richard C. Mains (Mains Associates, Berkeley, CA); Thomas N. Fast (U. of Santa Clara, Santa Clara, CA); Paul X. Callahan and Charles M. Winget, editors			8. Performing Organization Report No. A-89131		
			10. Work Unit No. 142-60-20		
9. Performing Organization Name and Address Ames Research Center Moffett Field, CA 94035			11. Contract or Grant No.		
			13. Type of Report and Period Covered Conference Publication		
12. Sponsoring Agency Name and Address National Aeronautics and Space Administration Washington, DC 20546-0001			14. Sponsoring Agency Code		
			15. Supplementary Notes Point of Contact: Paul X. Callahan, Ames Research Center, MS 240-A3, Moffett Field, CA 94035 (415) 694-6046 or FTS 464-6046		
16. Abstract <p>A conference, co-organized by the Space Life Sciences Payloads Office and the External Relations Office at Ames Research Center, was held from October 31 through November 4, 1988, at San Juan Bautista, California. Discussions and presentations at this conference addressed three aspects of cell research in space: (i) the suitability of the cell as a subject in microgravity experiments, (ii) the requirements for generic flight hardware to support cell research, and (iii) the potential for collaboration between academia, industry, and government to develop these studies in space. This publication gives synopses of the presentations and of follow-on discussions at the conference and contains papers from which the presentations were based. An Executive Summary outlines the recommendations and conclusions generated at the conference.</p>					
17. Key Words (Suggested by Author(s)) Gravitational cell biology, Gravity unloading, Generic flight hardware, Clinostats, Bioreactors			18. Distribution Statement Unclassified-Unlimited  Subject Category - 55		
19. Security Classif. (of this report) Unclassified		20. Security Classif. (of this page) Unclassified		21. No. of Pages 333	22. Price A14